

# Gearboxes for BMO5 motors

Two gearboxes are available from stock that fit directly to BMO5 motors. The programme provides the choice of heavy duty spur or planetary gearing systems that together offer torque ratings up to 25 Nm and speeds down to 3 rpm.

## Multi-role instrument gearhead

The MRIG series gearheads have been designed for use in heavy duty instrumentation or light duty industrial drive application. The combination of a hardened metal spur gear train coupled with a precision die-cast housing results in a robust design with a high torque transmission capability. In standard form the unit is provided with heavy duty sleeve bearings, ball bearings being available as an extra cost option.

MRIG has been designed to fit a wide range of motors that include BMO5 Brushless dc motors:

## MRIG series



### Dimensions: mm.

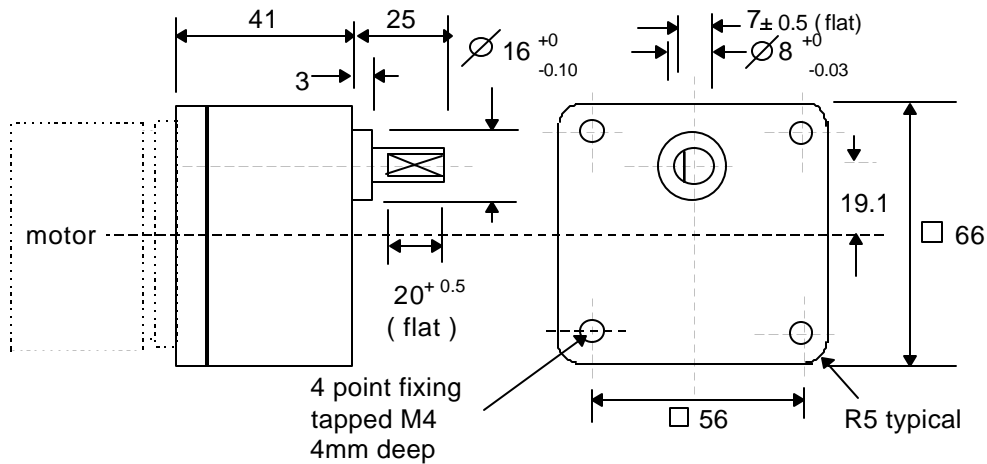

### Specification

Maximum Peak Output torque	: 7 Nm
Maximum motor input shaft diameter	: 6.35 mm
Style 1 Motor mounting	: direct to backplate
Suitable motors	: ac synchronous motors
	: stepper motors
	: dc servo motors
	: brushless dc motors
Maximum recommended continuous input speed	: 1600 rpm
Gear & pinion material	: metal throughout
Housing	: precision metal diecasting
Bearings	:
Sleeve bearings throughout	: MRIG..S types
Ball race bearings on output	: MRIG..B types
Maximum axial load	: 80 N ( MRIG..S types )
	: 150 N ( MRIG..B types )
Maximum radial load ( @ centre of shaft )	: 80 N ( MRIG..S types )
	: 160 N ( MRIG..B types )
Lubrication	: grease

## Standard Gear ratio options:

## MRIG series

Order Code	Gear ratio	Number of stages	Direction of rotation**	Efficiency	Maximum continuous output torque
MRIG02*	5:1	3	opposite	72%	1.5 Nm
MRIG06*	25:2	3	opposite	72%	2.5 Nm
MRIG11*	25:1	4	same	65%	4.0 Nm
MRIG17*	50:1	4	same	65%	4.0 Nm
MRIG22*	100:1	5	opposite	58%	4.0 Nm
MRIG23*	125:1	5	opposite	58%	5.0 Nm
MRIG27*	250:1	6	same	52%	6.0 Nm
MRIG34*	500:1	6	same	52%	7.0 Nm

**ABOVE TORQUE RATINGS ARE THE MAXIMUM LIMIT OF THE MRIG GEARHEAD**

Note \* : Add 'S' for version with sleeve bearings  
Add 'B' for version with ball race bearings

\*\* Direction of rotation with respect to input.

### motor mounting:

The BMO5 motor fits directly to the MRIG gearhead

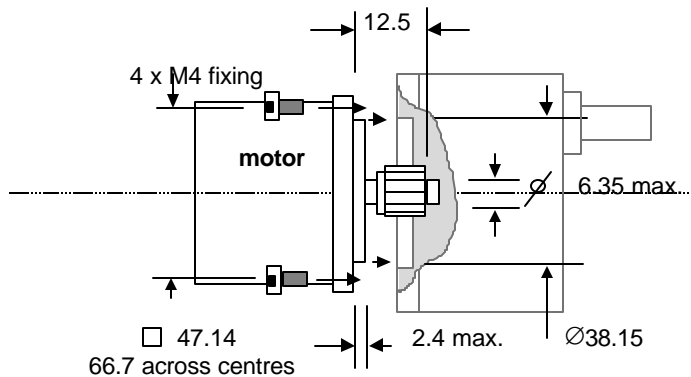

### Typical geared motor performance

Determine the speed & torque required in the application.

For example, if a maximum continuous speed of 60 rpm is required a motor speed of 1500rpm will be required if the MRIG11S ( 25:1) ratio is selected.

$$\begin{aligned}
 \text{IE:} \quad \text{Input speed} &= \text{Output speed} \times \text{ratio} = 60 \times 25 = 1500 \text{ rpm.} \\
 \text{If maximum output torque required} &= 3.5 \text{ Nm} \\
 \text{Input torque} &= \frac{\text{Output torque}}{\text{Ratio} \times \text{Efficiency}} = \frac{3.5\text{Nm}}{25 \times 0.65^*} = 0.21 \text{ Nm}
 \end{aligned}$$

From the BMO5 data sheet select type BMO5-2SQ that provides a torque of 0.22 Nm.

If a greater torque is required the BMO5-3SQ motor may be selected but if the required torque exceeds the 4 Nm gearhead rating the IP57 gearhead is recommended.

$$\begin{aligned}
 \text{IE:} \quad \text{Maximum motor torque for BMO5-3} &= 0.32 \text{ Nm} \\
 \text{Using IP57-M02-25:1 Planetary gearhead, Output torque} &= 0.32 \times 25 \times 0.84^* \\
 &= 6.7\text{Nm}
 \end{aligned}$$

**Note\*:** Gear efficiency for MRIG gearboxes is shown in the table above & that for IP57 gearboxes is shown in the data sheet overleaf

# Industrial Planetary gearheads

## IP series

The IP series gearheads have been designed to provide long life in industrial automation, industrial, scientific and process control applications that require repetitive cycling featuring high dynamics, accurate velocity or positional control. Advanced manufacturing techniques, combined with a design focused on the needs of state of the art motion control has resulted in a combination of optimised performance characteristics combined with economic prices. The unit is ideally suited to the BMO5 series brushless dc motor where a combination of high operating torque at reduced speed is required in applications that require long maintenance free life.



### Key features

- Planetary construction for high torque and compact dimensions
- Standard NEMA frame sizes
- Suitable for use with both servo and stepper motors
- Wide range of standard ratios with additional options also available
- Exact gear ratios simplify calibration in positional control systems
- 'Simplefit' mounting kit option to fit most motors
- Standard options available from stock

### Wide range of standard ratios:

IP series gearheads are available in a wide range of ratios, many of which being from stock as shown below:

Single stage units	2 stage units	3 stage units
4:1	16:1	125:1
• 5:1	20:1	250:1
7:1	• 25:1	500:1
• 10:1	• 50:1	1000:1
	70:1	
	• 100:1	

### • Standard ratios:

Gear ratio options shown in **bold** are usually available from stock

### Semi-standard

Other ratios are also readily available to special order.

### Specification

Gearhead	Number of stages	Maximum Continuous Torque * ( Nm )	Max. Peak Torque* ( Nm )	Typical Backlash (arc min.)	Efficiency	Max. Input Speed (rpm)	Max. Radial Load ( N )	Max. Axial Load ( N )
<b>IP057-M01</b>	1	6.0	12	20	92%			
<b>IP057-M02</b>	2	15	24	30	84%	5000	500	350
<b>IP057-M03</b>	3	25	40	40	78%			

Note \* De-rate by 10% for gear ratio of 10:1

# Industrial Planetary gearheads

# IP57 series

## Dimensions:

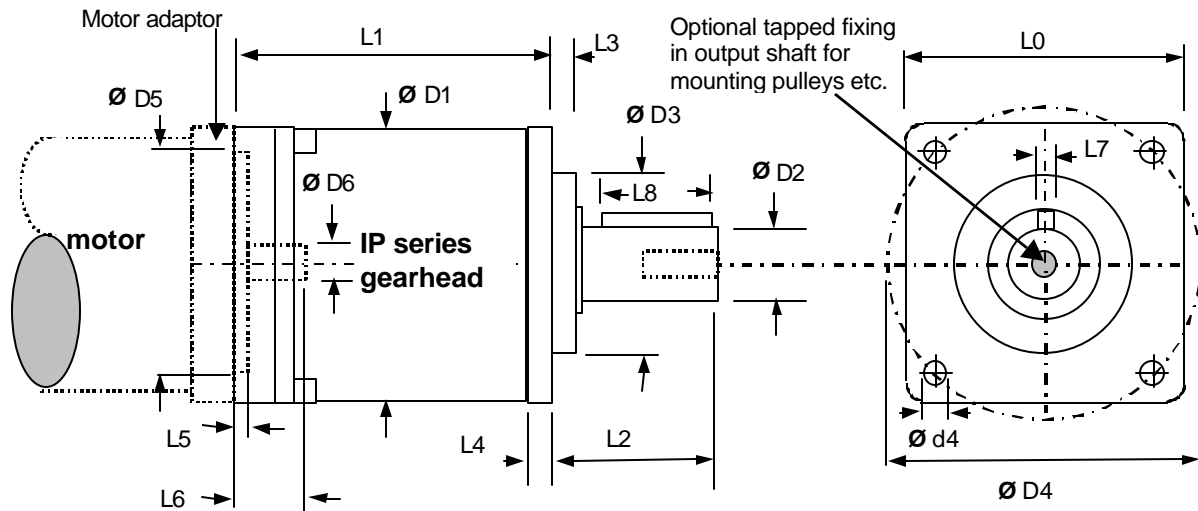

**Table of dimensions: mm**

Gearhead model		MO1	IP 57 MO2	MO3
Gearhead flange square	L0	57.2		
Gearhead Length	L1	54		
Ratios 3:1 4:1 5:1		67.75	66	92.75
10:1			79.75	
25:1				
50:1 100:1				
250:1 500:1 1000:1				
Shaft length from flange	L2	25.4		
Output Register length	L3	1.6		
Flange thickness	L4	5.2		
Input register length	L5	2.5		
Max. input shaft length	L6	Dependent on adapter length		
Output shaft Key width	L7	3.2		
Output shaft key length	L8	19.0		
<b>Diametric dimensions</b>				
Gearhead diameter	D1	57.2		
Output shaft diameter	D2	12.67 / 12.69 *		
Output register diameter	D3	38.05 / 38.10		
Mounting hole PCD	D4	66.68		
Mounting hole diameter	D4	5.1		
Input register diameter	D5	38.10 / 38.12		
Max. motor shaft dia.	D6	8		

Note \* Metric shafts are available to special order as follows: IP57:  $\varnothing$  12 mm

## Clamp pinion for IP series Planetary gearhead

IP series gearheads are provided with an optional pinion with an integrated clamp for easy mounting to the motor shaft.

Simply slide the pinion into the correct position on the motor's shaft and tighten the clamp

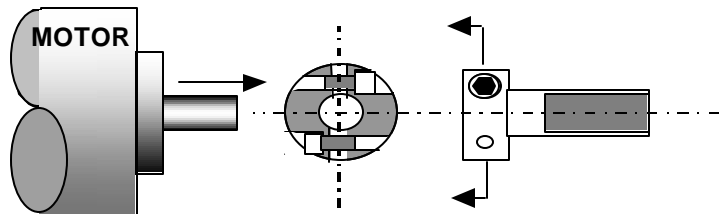

## Easyfit pinion with clamp