



Encoder Kit R

Components for Rotary Measurement

Encoder Kit R

The Encoder Kit R is a minimum configuration of a rotary encoder for use in situations where installation space is limited. The kit is based on the miniaturized and multifunctional EPIFLEX measuring module and on aluminum grating disks. The grating disks are scanned in reflected light.

Features

- Compact, highly integrated design of the EPIFLEX measuring module; all functional components of a measuring system have been deposited on a glass substrate using microelectronic technologies
- Variable use due to modular design
- Minimum dimensions of the EPIFLEX measuring module
- Extremely flat design
- Allows rough installation tolerance limits; optional: user-friendly pre-alignment of the measuring module in a mechanical frame
- Low mass moment of inertia of the grating disk
- High measuring speed due to high limit frequency of the EPIFLEX measuring module
- Variable signal interface

Fields of application

Fields of application where rotational movements, angles or revolutions must be measured in confined installation conditions:

- Automation technology
- Drive systems
- Instruments and machines used in the microelectronic industry
- Robot and handling technology
- High-precision engineering
- Metrology
- Rotary axes
- Medical technology

Modular Design

Installation of the EPIFLEX measuring module

In the standard versions, the measuring modules are placed in steel or aluminum frames and mechanically adjusted to the outside diameter D_a and inside diameter D_i .

If the frame is placed against a locating collar provided by the user with $\varnothing D_A H6$ or $\varnothing D_i h6$, the Encoder Kit R will need no further mechanical adjustment to be fully functional, provided that

- the disk is centered, and
- the specified distance z between the measuring module and grating disk is maintained.

The mount is fastened by screws.

If the measuring module is to be used without frame, additional tolerance must be complied with in two translational and one rotational degree of freedom.

The measuring module is then fastened by adhesive.

Signal adjustment

After mechanical installation, electronic signal adjustment is possible to optimize measuring module output signals.

This can result in

- a reduction of the interpolation error, and
- activation of functional reserves.

Signal adjustment can be performed with the aid of

- the adjustment kit together with an oscilloscope and a PC, or
- the signal monitor.

Electronic adjustment is recommended for Encoder Kit R with 25-fold interpolation and higher.

Electronic adjustment is essential if the measuring module is used without frame or in a custom-designed frame.

Modular Design — Signal Processing on the Connector Board

ENCODER Kit R

consists of: Kit R, grating disk, connecting cable
 designation example: **Kit R 12 B 040,4/3600 L4**
 (measuring module fixed in the frame, connector board)
RS 40.4/10/3600
Kab A A 1.0 O

Measuring module in standard frame (B)

Measuring module and connector board are interfaced and electronically adjusted.

Measuring module without frame (A) or in special frame

Measuring module is preadjusted and set to the signal interface of the electronic unit.

Measuring module is **not** interfaced with the connector board.

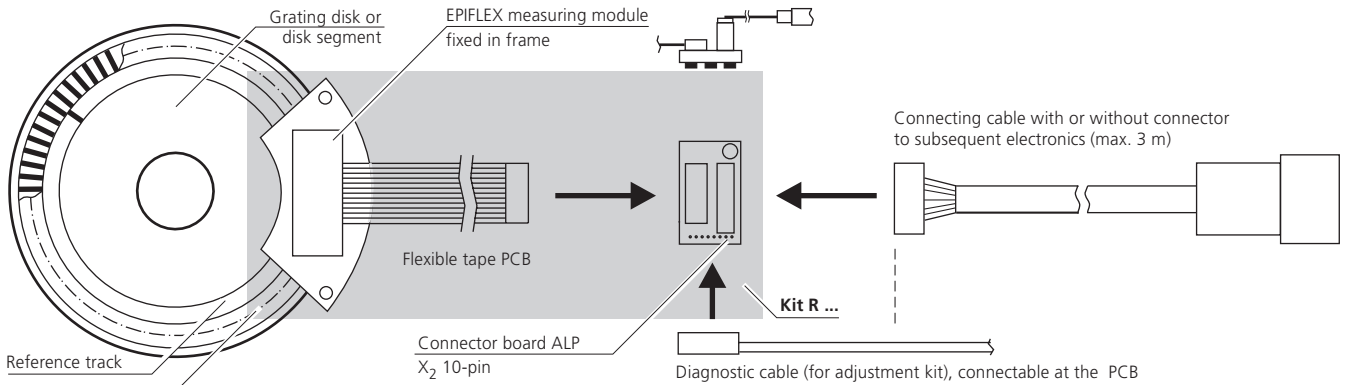

Signals: Output measuring module = input connector board

sin 1 V_{pp}

sin 1 V_{pp}

sin 11 μA_{pp}

sin 11 μA_{pp}

Output connector board = output cable/connector

sin 1 V_{pp}

square-wave signal RS 422; **without** interpolation

sin 11 μA_{pp}

square-wave signal RS 422; **with** interpolation
 interpolations factor is fixed
 max. output frequency (min. edge separation) is fixed

Connector board X₂ 10-pin

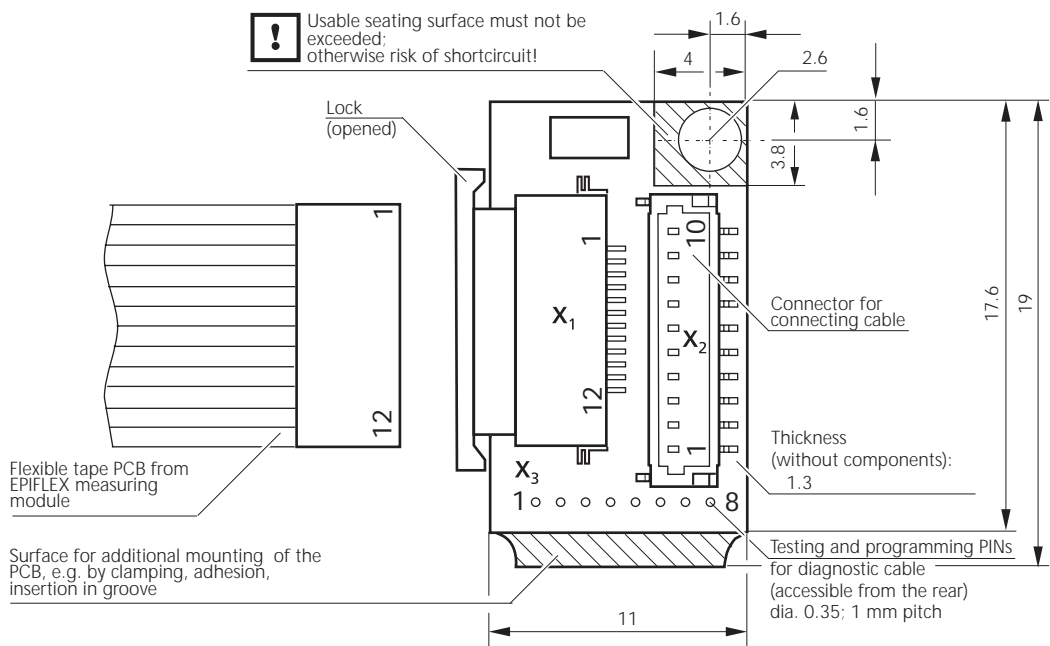

Modular Design — Signal Processing in the Connector

ENCODER Kit R

consists of:

Kit R, grating disk

designation example:

Kit R 12 B 040.4/3600 L4FZ
(measuring module fixed in the frame, connector board, round cable with 15-pin D-Sub connector)

RS 40.4/10/3600

A vacuum version in this configuration is not available.

Measuring module in standard frame (B)

Measuring module, connector board and cable with connector are interfaced and electronically adjusted.

Measuring module without frame (A) or in special frame

Measuring module is preadjusted and set to the signal interface of the electronic unit.

Measuring module is **not** interfaced with connector board and cable.

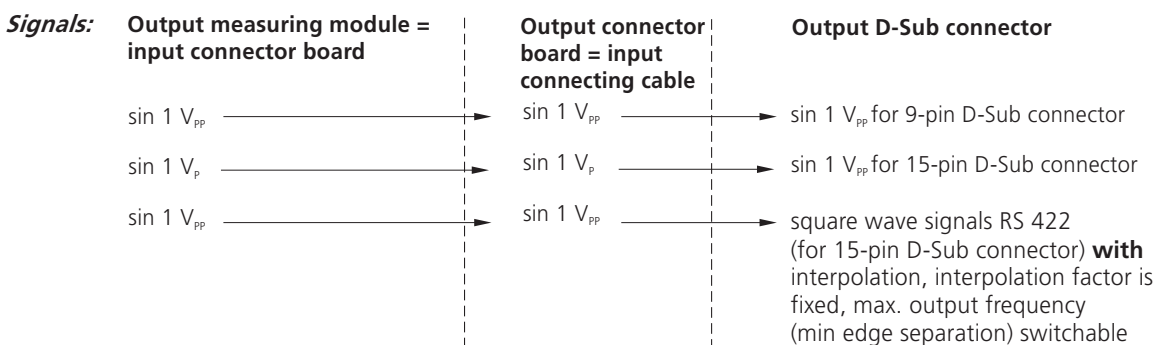
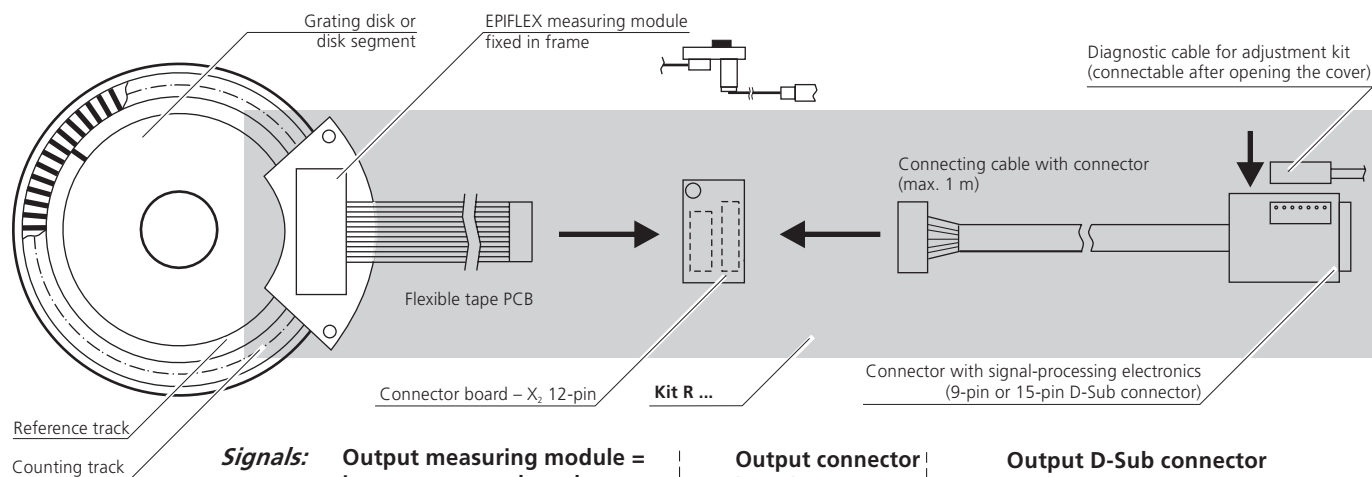

Connector board X₂ 12-pin

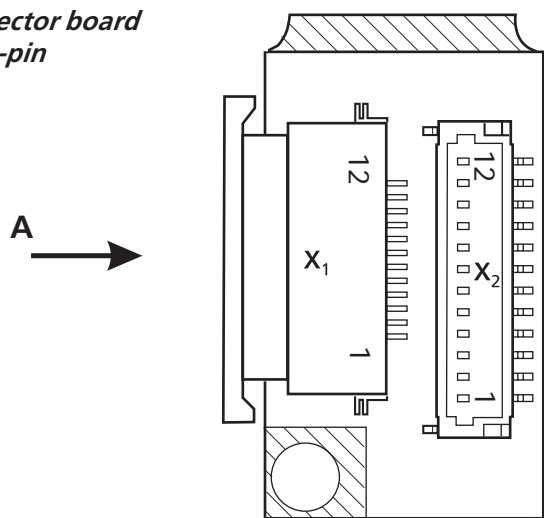

Dimensions see connector board page 3

Proposed Mounting of Connector Board View A (shown without connector X₁)

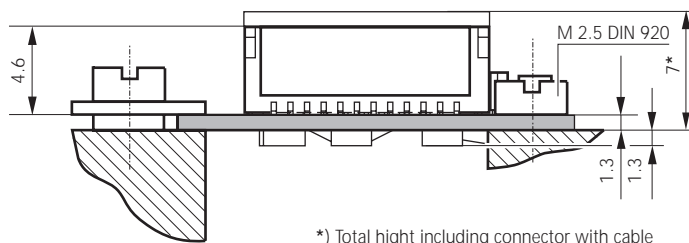

*) Total height including connector with cable

Modular Design — without Signal Processing

ENCODER Kit R

consists of: EPIFLEX measuring module
grating disk

designation example: **EMR 12 B 040.4/3600 CO**
(measuring module with frame)
RS 40.4/10/3600

Driven square-wave signals

When using this interface, note that the reference pulse (in contrast to the versions with signal processing) is not gated with the counting pulses.

When approached from different directions, the hysteresis of the reference pulse can reach approx. one signal period.

Measuring module in standard frame (B)

Measuring module is electronically adjusted.

Measuring module without frame (A) or in special frame

Measuring module is preadjusted and set to the signal output according to ordering key.

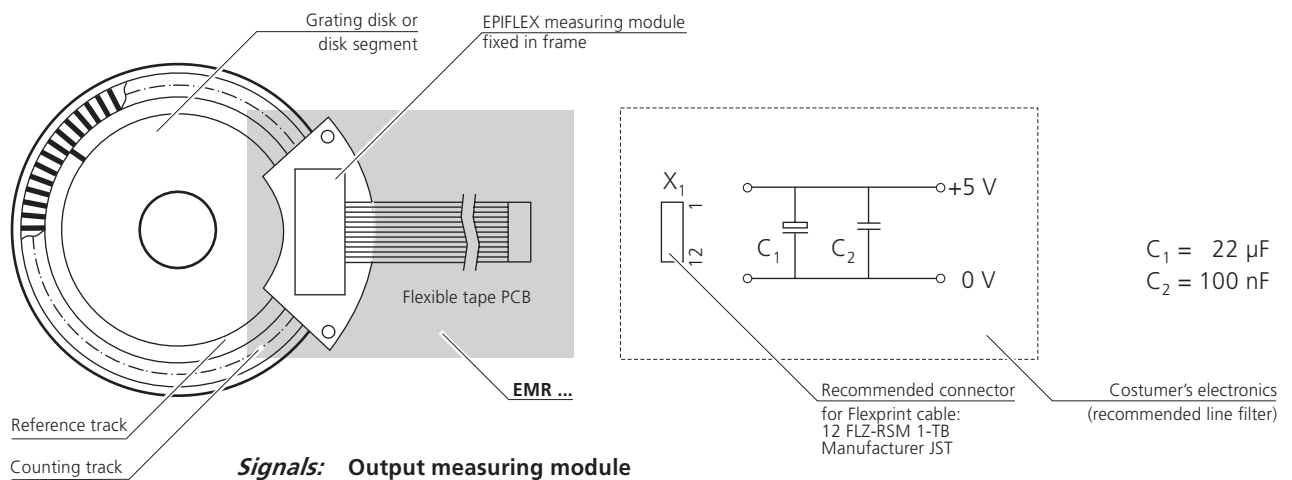

Signals: Output measuring module

- sin $1 V_{pp}$
- sin $11 \mu A_{pp}$
- square wave signals RS 422

Pin assignment X_1

Pin	1	2	3	4	5	6	7	8	9	10	11	12
sin $11 \mu A_{pp}$	SCL	SDA	GND	CS	I_{1+}	I_{1-}	NAS	I_{0-}	I_{0+}	I_{2+}	I_{2-}	U_B
sin $1 V_{pp}$	SCL	SDA	GND	CS	U_{1-}	U_{1+}	NAS	U_{0+}	U_{0-}	U_{2-}	U_{2+}	U_B
RS 422	SCL	SDA	GND	CS	Z_{1-}	Z_{1+}	NAS	R+	R-	Z_{2-}	Z_{2+}	U_B

Legend

I_{1+}	U_{1+}	sin-signal (counting track)	Z_{1-}	negated counting signal 0° (180°)	AS	monitoring signal
I_{2+}	U_{2+}	cos-signal (counting track)	Z_{2-}	negated counting signal 90° (270°)	NAS	negated monitoring signal
I_{1-}	U_{1-}	- sin-signal (counting track)	R+	reference signal	<i>NAS high:</i>	
I_{2-}	U_{2-}	- sin-signal (counting track)	R-	negated reference signal	input signals within tolerance range;	
I_{0+}	U_{0+}	reference signal	U_B	supply voltage (+ 5 V)	measuring system functioning	
I_{0-}	U_{0-}	- reference signal	GND	earth (0 V)	<i>NAS low:</i>	
Z_{1+}		counting signal 0°	SCL, CS	} adjustment pins (for electronic signal adjustment)	measuring system in disorder	
Z_{2+}		counting signal 90°	SDA			

Installation Dimensions

Grating disks available — Ordering key

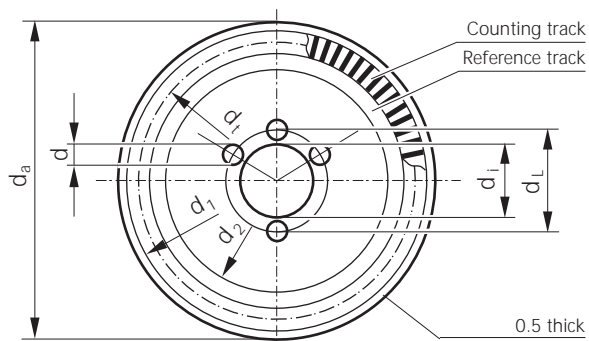

Type/Ordering key	d_a	d_t	d_i	d_1	d_2	d_L	d	Z^*
RS 40.4/10/1800	$46_{-0.5}^{-0.2}$	40.4	10^{M5}	44	32	14.5	2.3	1800
RS 40.4/10/2048	$46_{-0.5}^{-0.2}$	40.4	10^{M5}	44	32	14.5	2.3	2048
RS 40.4/10/3600	$46_{-0.5}^{-0.2}$	40.4	10^{M5}	44	32	14.5	2.3	3600
RS 40.4/25/1800	$46_{-0.5}^{-0.2}$	40.4	25 +0.1	44	32	—	—	1800
RS 40.4/25/2048	$46_{-0.5}^{-0.2}$	40.4	25 +0.1	44	32	—	—	2048
RS 40.4/25/3600	$46_{-0.5}^{-0.2}$	40.4	25 +0.1	44	32	—	—	3600
RS 64.4/48.5/2048	$71.5_{-0.5}^{-0.2}$	64.4	48.5 +0.1	68	56	—	—	2048
RS 64.4/48.5/9000	$71.5_{-0.5}^{-0.2}$	64.4	48.5 +0.1	68	56	—	—	9000
RS 64.4/48.5/10000	$71.5_{-0.5}^{-0.2}$	64.4	48.5 +0.1	68	56	—	—	10000
RS 92.4/70/3600	$100_{-0.5}^{-0.2}$	92.4	70 +0.1	96	84	—	—	3600
RS 92.4/70/9000	$100_{-0.5}^{-0.2}$	92.4	70 +0.1	96	84	—	—	9000
RS 92.4/70/18000	$100_{-0.5}^{-0.2}$	92.4	70 +0.1	96	84	—	—	18000
RS 142.4/120/5400	$150_{-0.5}^{-0.2}$	142.4	120 +0.2	146	134	—	—	5400
RS 142.4/120/18000	$150_{-0.5}^{-0.2}$	142.4	120 +0.2	146	134	—	—	18000

*) Number of lines of the grating disk

Connecting cables

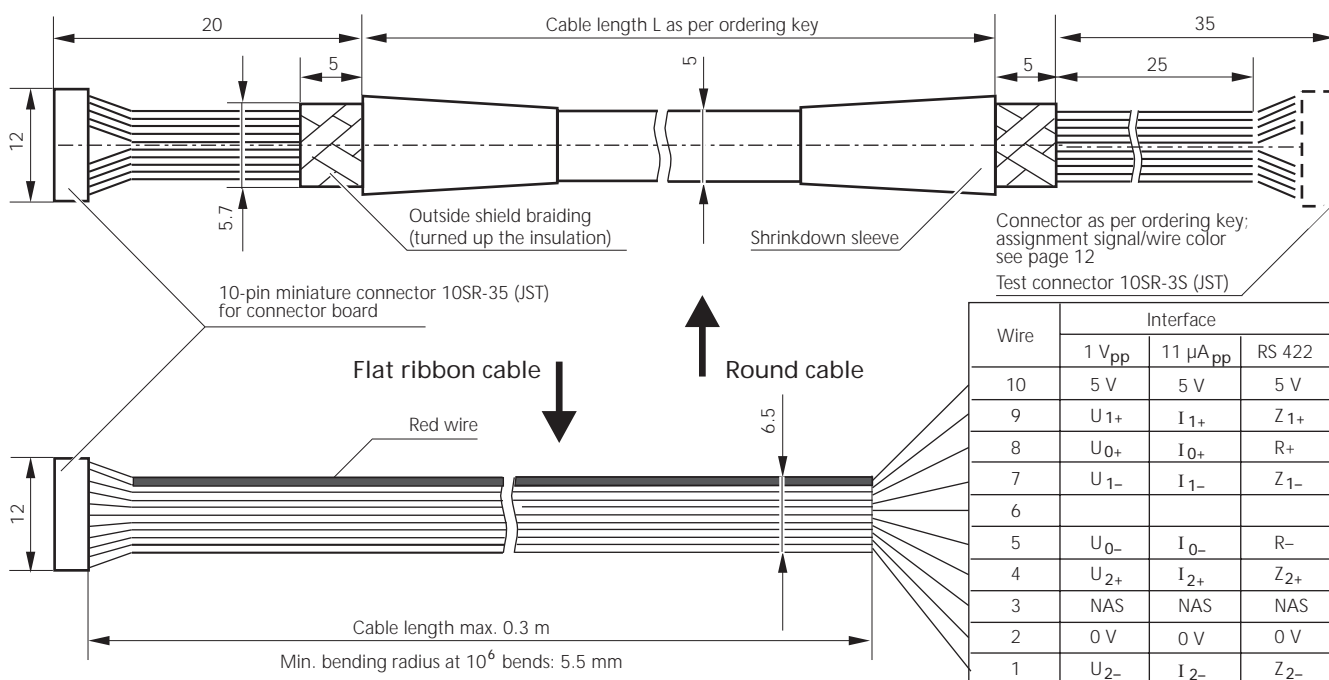

Installation Dimensions

EPIFLEX measuring module with frame

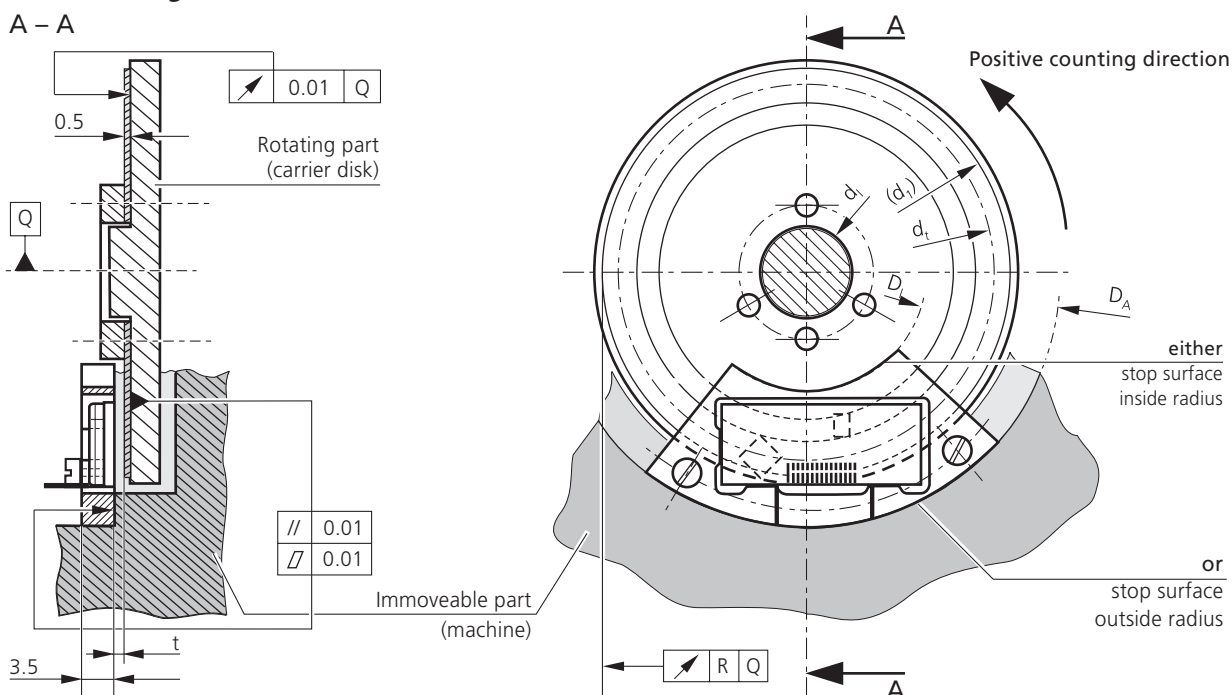

Dimensions and tolerance limits to be observed by the user to ensure proper functioning, without angular error being taken into account

*) alternatively D_A or D_i

***) Radial eccentricity of the disk bearing

Type	d_i	D_A^*	D_i^*	(d_t)	R	R^{**}	t
RS 40.4/10/1800	10 _{fg4}	55 ^{H6}	26 _{h6}	44	–	0.01	0.7 ±0.05
RS 40.4/10/2048	10 _{fg4}	55 ^{H6}	26 _{h6}	44	–	0.01	0.7 ±0.05
RS 40.4/10/3600	10 _{fg4}	55 ^{H6}	26 _{h6}	44	–	0.01	0.4 ±0.03
RS 40.4/25/1800	–	55 ^{H6}	26 _{h6}	44	0.015	–	0.7 ±0.05
RS 40.4/25/2048	–	55 ^{H6}	26 _{h6}	44	0.015	–	0.7 ±0.05
RS 40.4/25/3600	–	55 ^{H6}	26 _{h6}	44	0.015	–	0.4 ±0.03
RS 64.4/48.5/2048	–	82 ^{H6}	50.8 _{h6}	68	0.015	–	0.8 ±0.05
RS 64.4/48.5/9000	–	82 ^{H6}	50.8 _{h6}	68	0.015	–	0.6 ±0.05
RS 64.4/48.5/10000	–	82 ^{H6}	50.8 _{h6}	68	0.015	–	0.5 ±0.05
RS 92.4/70/3600	–	110 ^{H6}	78 _{h6}	96	0.015	–	0.5 ±0.05
RS 92.4/70/9000	–	110 ^{H6}	78 _{h6}	96	0.015	–	0.4 ±0.03
RS 92.4/70/18000	–	110 ^{H6}	78 _{h6}	96	0.015	–	0.35 ±0.05
RS 142.4/120/5400	–	160 ^{H6}	126 _{h6}	146	0.015	–	1.2 ±0.05
RS 142.4/120/18000	–	160 ^{H6}	126 _{h6}	146	0.015	–	1.2 ±0.05

Frame for EPIFLEX measuring module; standard frame B according to ordering key

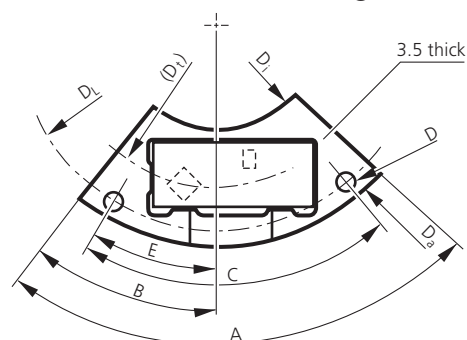

Type	D_a	D_t	D_i	D_L	D	A	B	C	E
MF 40.4	55 _{h6}	40.4	26 ^{H6}	51 ±0.1	2.2	86°	38°	70°	30°
MF 64.4	82 _{h6}	64.4	50.8 ^{H6}	77 ±0.1	2.2	54°	27°	44°	22°
MF 92.4	110 _{h6}	92.4	78 ^{H6}	106 ±0.1	2.2	40°	20°	34°	17°
MF 142.4	160 _{h6}	142.4	126 ^{H6}	156 ±0.1	2.2	26°	13°	22°	11°

Installation Dimensions

EPIFLEX measuring module without frame

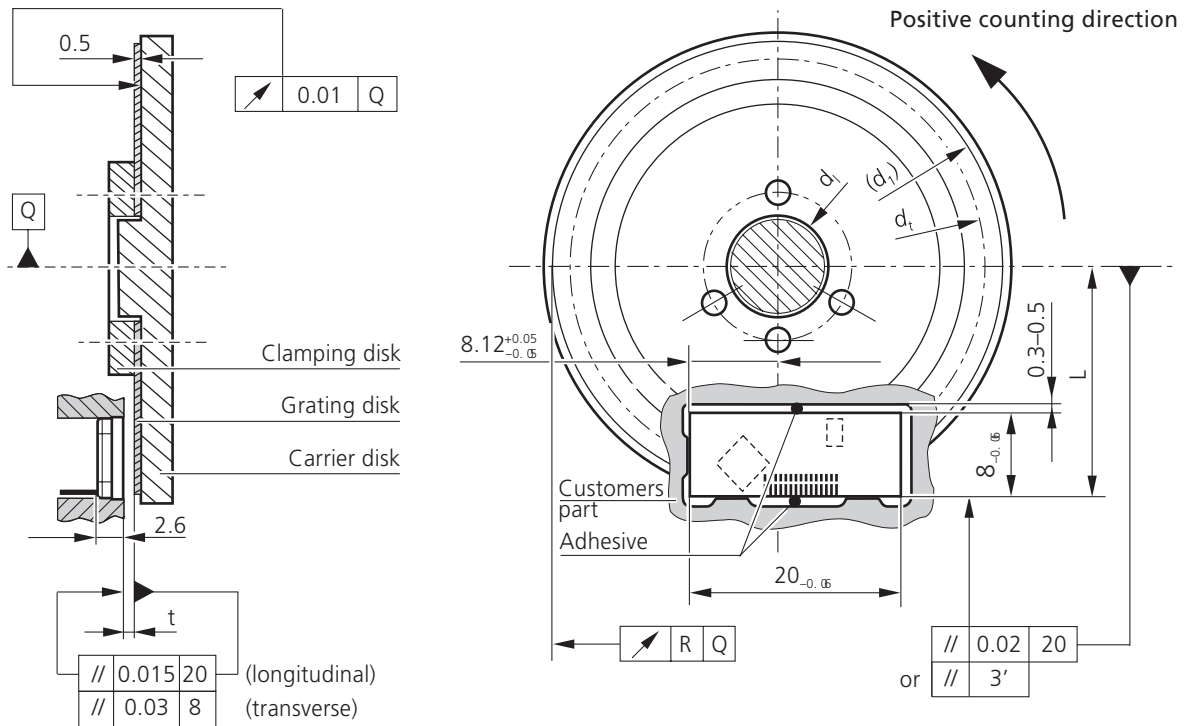

Bonding of the EPIFLEX measuring module outside the 3 contact pads on both longitudinal sides.

Dimensions and tolerance limits to be observed by the user to ensure proper functioning, without angular error being taken into account

***) Radial eccentricity of the disk bearing

Type	d_1	R	R**	(d_1)	L
RS 40.4/10/1800	10 _{fg4}	–	0.01	44	22.65 ±0.05
RS 40.4/10/2048	10 _{fg4}	–	0.01	44	22.65 ±0.05
RS 40.4/10/3600	10 _{fg4}	–	0.01	44	22.65 ±0.05
RS 40.4/25/1800	–	0.015	–	44	22.65 ±0.05
RS 40.4/25/2048	–	0.015	–	44	22.65 ±0.05
RS 40.4/25/3600	–	0.015	–	44	22.65 ±0.05
RS 64.4/48.5/2048	–	0.015	–	68	34.78 ±0.03
RS 64.4/48.5/9000	–	0.015	–	68	34.78 ±0.03
RS 64.4/48.5/10000	–	0.015	–	68	34.78 ±0.03
RS 92.4/70/3600	–	0.015	–	96	48.89 ±0.05
RS 92.4/70/9000	–	0.015	–	96	48.89 ±0.05
RS 92.4/70/18000	–	0.015	–	96	48.89 ±0.05
RS 142.4/120/18000	–	0.015	–	146	73.96 ±0.05
RS 142.4/120/5400	–	0.015	–	146	73.96 ±0.05

Proposed mounting of grating disk

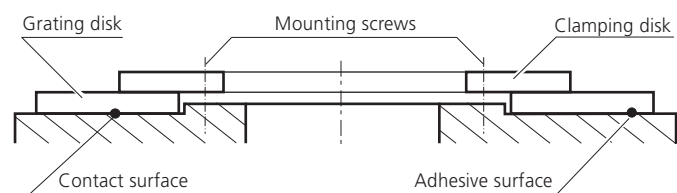

Clamping (only for RS 40.4/10 ... and RS 92.4 ...) or full-surface bonding (without clamping disk)

Technical Specification

Resolution

Resolution A is defined as the smallest angular value which is still detected by the evaluating electronics (display, control) when the grating disk is turned relative to the EPIFLEX measuring module.

The resolution can be calculated using the following formula:

$$A = Z \cdot i \cdot N \quad \text{in increments/revolution}$$

$$A = \frac{360^\circ}{Z \cdot i \cdot N} \quad \text{in degrees}$$

Z the number of lines on the grating disk

i interpolation factor of the connector board (5x, 10x, 25x or 50x)

N factor for evaluation mode in the counter

N = 1 for single-edged evaluation

N = 2 for double-edged evaluation

N = 4 for quad-edged evaluation

Elektrical data

Scanning frequency max. 500 kHz

Output interfaces

– voltage output 1 V_{pp}
with integrated line driver

– current output 11 μA_{pp}
– square-wave output RS 422;
optionally with internal
signal interpolation 5/10/25/50x

Supply voltage 5 V ± 10%

Power consumption

– voltage output < 60 mA

– current output < 30 mA

– square-wave output
(RS 422) < 180 mA

Cable length – connecting cable

(round cable) 1 m with connector; other lengths
on request;
for greater lengths use extension
cable

Permissible cable lengths
(with extensions)

max. 18 m
for current output 11 μA_{pp}
max. 100 m
for voltage output 1 V_{pp}
max. 100 m
for square-wave output RS 422

Accuracy

Accuracy (extremes of direction deviations) is affected by

- graduation errors of the grating disk
- eccentricity of the graduation relative to the axle bearing
- radial eccentricity of the axle bearing
- deviations in the positions of the grating disk and the EPIFLEX measuring module (installation tolerance)
- interpolation error in signal processing

The accuracy is largely determined by the eccentricity of the graduation relative to the axle bearing and the radial eccentricity of the axle bearing.

The error resulting from these factors is calculated using the following formula:

$$\Delta\phi = \pm 412 \frac{e}{D}$$

Δφ angular error in seconds of arc

e eccentricity of the graduation relative to the axle of rotation including the radial eccentricity of the axle bearing in μm

D graduation diameter of the grating disk in mm

Ambient conditions

Operating temperature range 0°C ... +55°C

Storage temperature range –20°C ... +70°C

Vibration (50 Hz ... 2000 Hz) ≤ 200 ms⁻²

Shock (11 ms) ≤ 400 ms⁻²

The way the EPIFLEX measuring module is designed – optoelectronic function elements on a glass substrate – it is alone not immune against electromagnetic radiation (EMC).

Mechanical data

Grating disks see ordering key page 6

Dimensions of

EPIFLEX measuring module 8 x 20 x 2.6 mm³

EPIFLEX measuring module
fixed in the frame see page 7

Maximum numbers

of revolution as a function

of the counter see table page 9 below

(The table already takes into account any limitation of the number of revolution due to signal tolerances.)

Z: number of lines of the grating disk

Interpolation	None	5x	10x	25x	50x
Max. speed (rpm)	$\frac{30.000.000}{Z}$	$\frac{30.000.000}{Z}$	$\frac{21.600.000}{Z}$	$\frac{8.640.000}{Z}$	$\frac{4.320.000}{Z}$
Min. edge separation of output signals at max. speed	0.33 μs	28 ns	28 ns	28 ns	28 ns
Min. counting frequency (clock frequency) of counter at max. speed	3 MHz	36 MHz	36 MHz	36 MHz	36 MHz

Safety factor without interpolation: 1.5

Safety factor with interpolation: 2.5

Ordering Key

Components for measurement of rotary motions

Kit R	1	2	B	040.4/3600	L	4	F	Z
-------	---	---	---	------------	---	---	---	---

Kit R	version with signal processing
EMR	version without signal processing

Type of sensor

1	dimensions 20 x 8 x 2.6
---	-------------------------

Flexible tape, length

1	25 mm
2	55 mm

Frame

A	without frame
B	standard/steel (passivated)
C	standard/aluminium (cromated)
D	customized frame on request
...	other frames

Optical diameter of graduation – number of lines

40.4	1800
40.4	2048
40.4	3600
64.4	2048
64.4	9000
64.4	10000
92.4	3600
92.4	9000
92.4	18000 ³
142.4	5400
142.4	18000

1 Only necessary if the electronic unit is inside the connector

2 Standard lengths: 0.3 m; 0.5 m; 1.0 m; 1.5 m; 2.0 m; 3.0 m; greater lengths with extension cable; other lengths on request

3 Electronic adjustment recommend; requires adjustment kit

Signal processing in the connector

Y ^{1,2}	9-pin; D-Sub; electronic unit inside the connector (1 V _{pp})
Z ^{1,2}	15-pin; D-Sub; electronic unit inside the connector (RS 422, 1 V _{pp})

Cable Kit R for signal processing in the connector

Cable Ø 3.7 mm		Cable Ø 5.1 mm	
R ¹	0.3 m	A ¹	0.3 m
S ¹	0.5 m	B ¹	0.5 m
T ¹	1.0 m	F ¹	1.0 m
P ¹	1.5 m	E ¹	1.5 m
V ¹	2.0 m	G ¹	2.0 m
W ¹	3.0 m	K ¹	3.0 m

Clock frequency/edge separation

X	min. counting frequency of counter (min. edge separation of the counting signals): only for version with interpolation
---	--

Output signals

B	sinusoidal signal 11 μA _{pp}
C	sinusoidal signal 1 V _{pp}
K	square-wave signal RS 422 without interpolation
L	square-wave signal RS 422 with interpolation 5x
M	square-wave signal RS 422 with interpolation 10x
I	square-wave signal RS 422 with interpolation 25x
N	square-wave signal RS 422 with interpolation 50x

For ordering key of grating disks see page 6

Ordering Key

Connecting cables for ENCODER Kit R

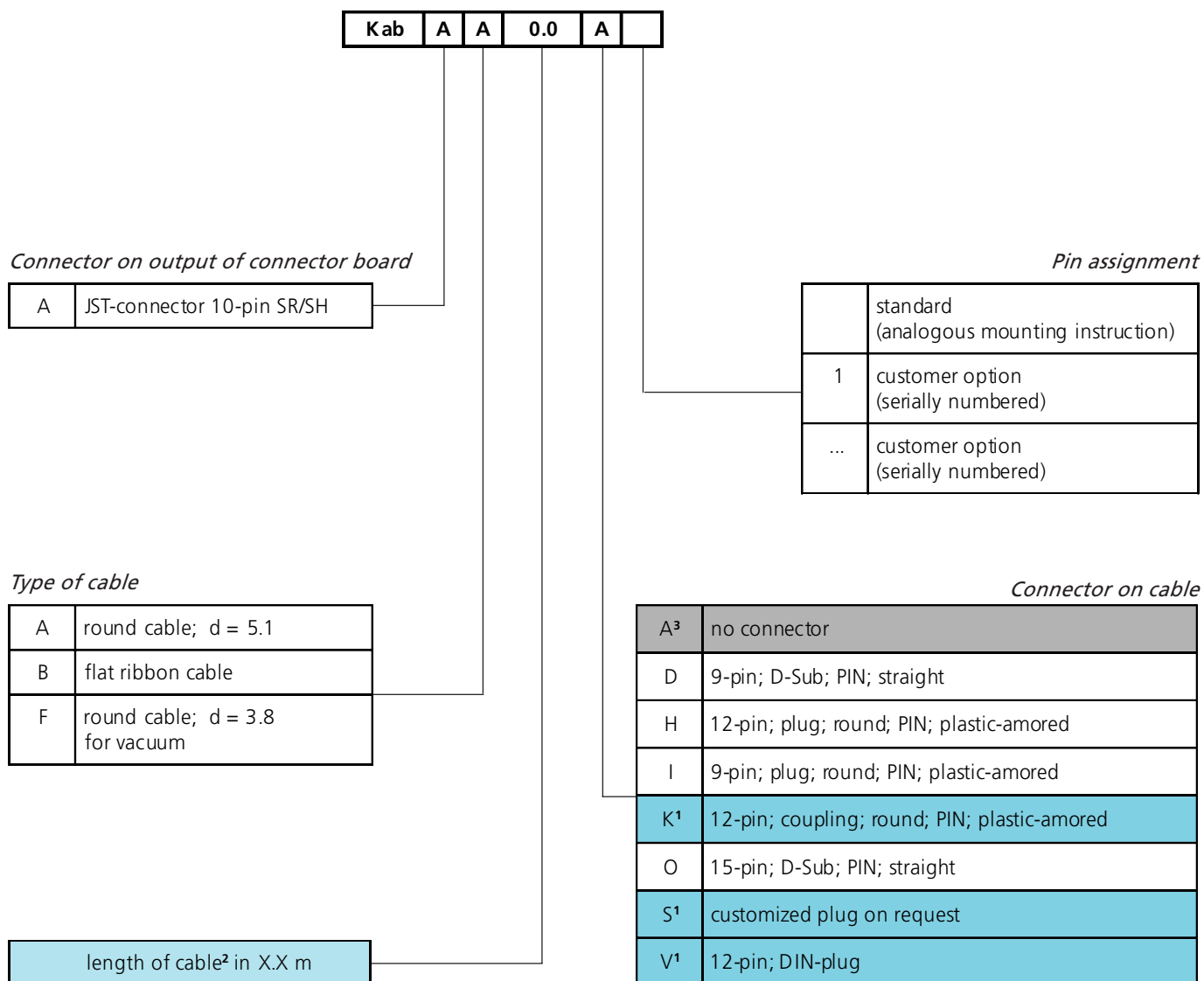

1 No standard, supplied against surcharge

2 Standard lengths: 0.3 m; 0.5 m; 1.0 m; 1.5 m; 2.0 m; 3.0 m; greater lengths with extension cable; other lengths on request

3 Supplied with test connector 10SR-3S (JST), only for cable type A

For standard pin assignment see page 12

Standard Pin Assignment

15-pin D-sub plug

PIN	1	2	3	4	5	6	7	8	9	10	11	12	13	14	15	Housing
sin 1 V _{pp}	–	–	–	U _{0–}	U _{2–}	U _{1–}	5 V	5 V	0 V	–	–	U ₀₊	U ₂₊	U ₁₊	–	Shield
RS 422	–	–	NAS	Z _{0–}	Z _{2–}	Z _{1–}	5 V	5 V	0 V	–	AS	Z ₀₊	Z ₂₊	Z ₁₊	–	Shield
Colour	–	–	violet	pink	red	yellow	brown	brown	white	–	black	grey	blue	green	–	

9-pin D-sub plug

Pin	1	2	3	4	5	6	7	8	9	Housing
sin 1 V _{pp}	U _{1–}	0 V	U _{2–}	–	U _{0–}	U ₁₊	5 V	U ₂₊	U ₀₊	Shield
RS 422	Z _{1–}	0 V	Z _{2–}	NAS	Z _{0–}	Z ₁₊	5 V	Z ₂₊	Z ₀₊	Shield
sin 11 μA _{pp}	I _{1–}	0 V	I _{2–}	–	I _{0–}	I ₁₊	5 V	I ₂₊	I ₀₊	Shield
Colour	yellow	white	red	violet	pink	green	brown	blue	grey	

12-pin circular connector (Ø 28; M 23 x 1)

Pin	1	2	3	4	5	6	7	8	9	10	11	12	Housing
sin 1 V _{pp}	U _{2–}	5 V	U ₀₊	U _{0–}	U ₁₊	U _{1–}	–	U ₂₊	–	0 V	0 V	5 V	Shield
RS 422	Z _{2–}	5 V	Z ₀₊	Z _{0–}	Z ₁₊	Z _{1–}	NAS	Z ₂₊	–	0 V	0 V	5 V	Shield
Colour	red	brown	grey	pink	green	yellow	violet	blue	–	white	white	brown	

9-pin circular connector (Ø 28; M 23 x 1)

Pin	1	2	3	4	5	6	7	8	9	Housing
sin 11 μA _{pp}	I ₁₊	I _{1–}	5 V	0 V	I ₂₊	I _{2–}	I ₀₊	I _{0–}	–	Shield
Colour	green	yellow	brown	white	blue	red	grey	pink	–	

12-pin DIN circular connector (Ø 18; M 18 x 0,75)

Pin	A	B	C	D	E	F	G	H	I	K	L	M	Housing
sin 1 V _{pp}	–	0 V	U ₁₊	U _{1–}	U ₂₊	0 V	U ₀₊	U _{0–}	0 V	5 V	U _{2–}	5 V	Shield
RS 422	–	0 V	Z ₁₊	Z _{1–}	Z ₂₊	0 V	Z ₀₊	Z _{0–}	0 V	5 V	Z _{2–}	5 V	Shield
Colour	–	white	green	yellow	blue	white	grey	pink	white	brown	red	brown	

For legend see page 5



NUMERIK JENA GmbH

Ilmstraße 4
D-07743 Jena
Germany

Telephone ++49 3641 47 28 21

Fax ++49 3641 47 28 20

E-mail info@numerikjena.de

Internet www.numerikjena.de