

Multi-role instrument gearhead

MRIG series

The MRIG series gearheads have been designed for use in heavy duty instrumentation or light duty industrial drive application. The combination of a hardened metal spur gear train coupled with a precision die-cast housing results in a robust design with a high torque transmission capability.

MRIG has been designed to fit a wide range of motors including:

- high torque reversible ac synchronous types
- permanent magnet & hybrid stepper motors
- dc servo motors with optional brake, encoder or tachogenerator.
- brushless dc motors



Robust construction with built motor mounting flexibility

A key feature of the MRIG design is its ability to accept standard motor shafts without the need for modification. This enables a wide range of motors including NEMA size 23 stepper motors to be fitted directly to the unit while dc and brushless servo motors are fitted using a simple mounting adapter. Gear strength is a key feature of the MRIG design. The use of steel gears and pinions with carefully selected hardness grades ensures a high torque transmission capacity and long life while a robust precision diecast metal housing offers excellent protection in industrial installations.

In its standard form MRIG gearheads are provided with heavy duty sleeve bearing on the output shaft, ball bearings being available to special order

Standard Gear ratios

Fast-track delivery of the following ratios is ensured by the maintenance of comprehensive stock levels. Geared motor combinations based on the MRIG gearhead series are assembled in our fast response assembly cell to provide our customers with fast delivery to meet their changing demands.

Order Code	Gear ratio	Number of stages	Direction of rotation**	Efficiency	Maximum continuous output torque
MRIG02 *	5:1	3	opposite	72%	1.5 Nm
MRIG06 *	25:2	3	opposite	72%	2.5 Nm
MRIG11 *	25:1	4	same	65%	4.0 Nm
MRIG17 *	50:1	4	same	65%	4.0 Nm
MRIG22 *	100:1	5	opposite	58%	4.0 Nm
MRIG23 *	125:1	5	opposite	58%	5.0 Nm
MRIG27 *	250:1	6	same	52%	6.0 Nm
MRIG34 *	500:1	6	same	52%	7.0 Nm



Note: * Add 'S' for standard Sleeve Bearings on Output shaft
'B' for ball bearings

** Direction of rotation of output compared to input

MRIG Series Dimensions: mm.

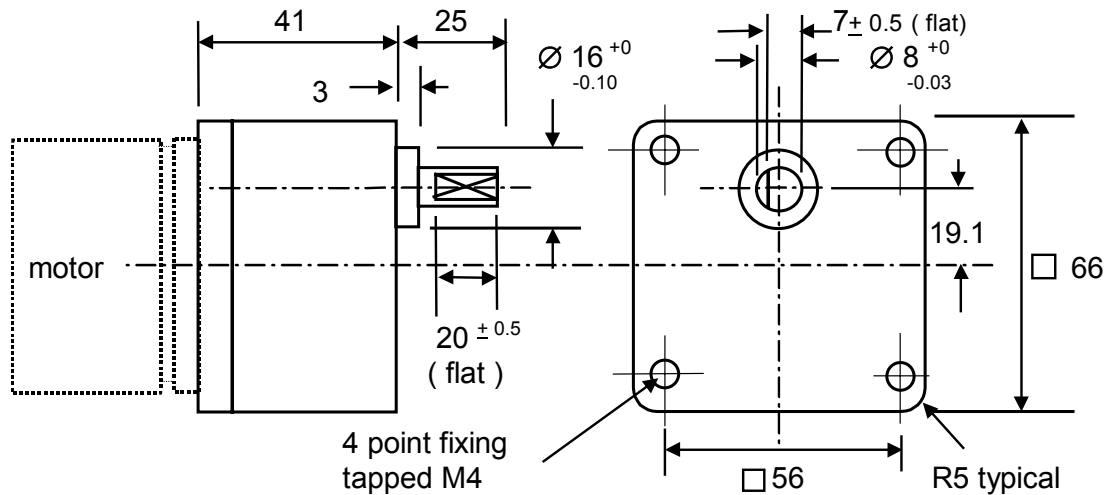

General Specification

Maximum Peak Output torque	: 7 Nm
Maximum continuous output power	: 25 watts
Maximum motor input shaft diameter	: 6.35 mm
Style 1 Motor mounting	: direct to backplate
Style 2 Motor mounting	: via adapter
Suitable motors	: ac synchronous motors : stepper motors : dc servo motors : Brushless dc motors
Maximum recommended continuous input speed	: 2500 rpm
Gear & pinion material	: metal throughout
Housing	: precision metal diecasting
Bearings	:
Sleeve bearings throughout	: MRIG..S types
Ball race bearings on output	: MRIG..B types
Maximum axial load	: 80 N (MRIG..S types) : 150 N (MRIG..B types)
Maximum radial load (@ centre of shaft)	: 80 N (MRIG..S types) : 160 N (MRIG..B types)
Lubrication	: grease

Multi-role instrument gearhead

MRIG series

Fitting typical NEMA size 23 hybrid stepper motor

dimensions: mm

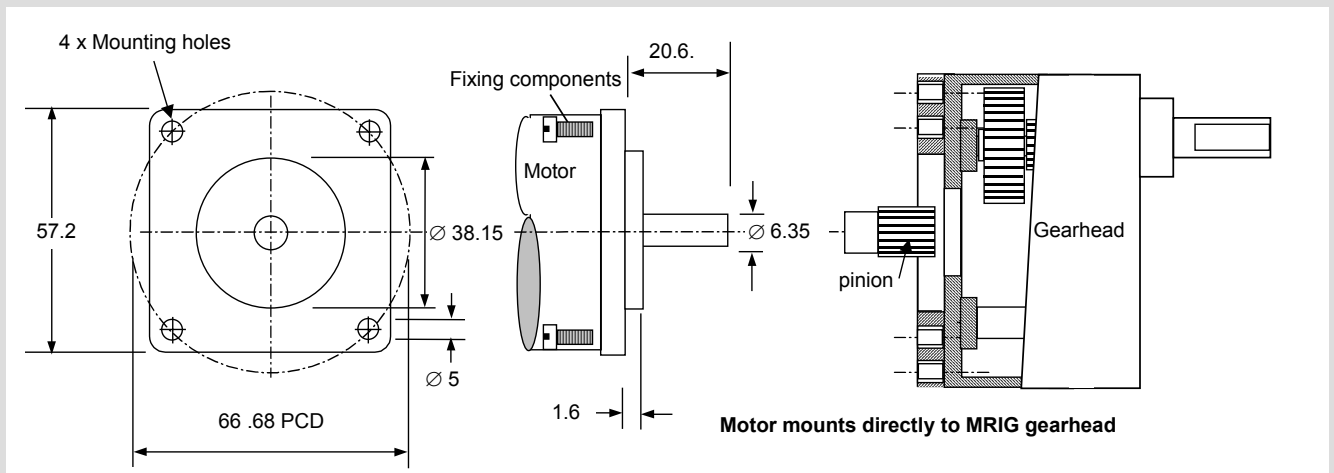

Mounting motors with round flange using adapter

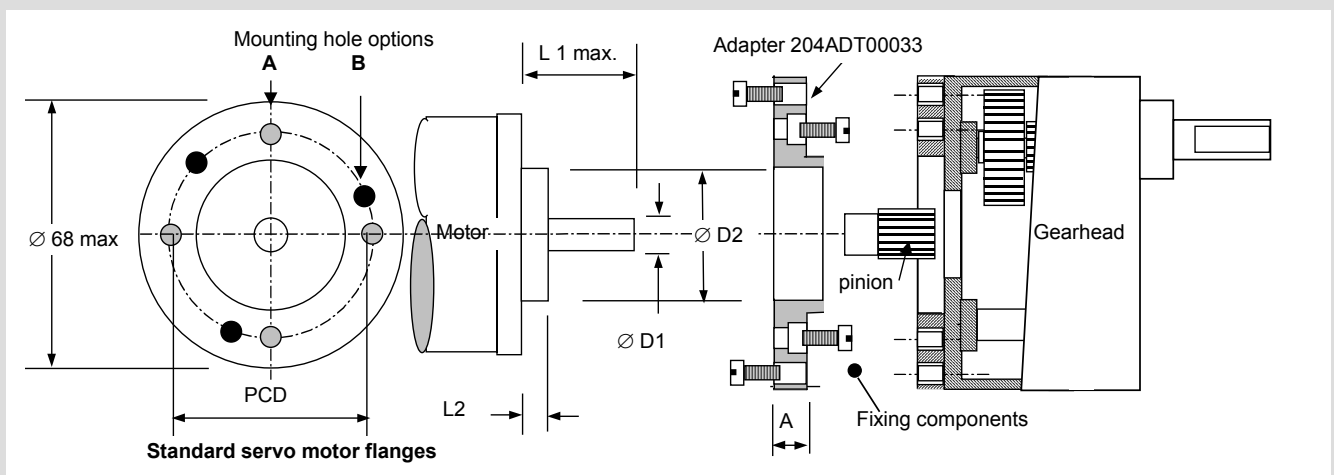

Mounting motors with square flange using adapter

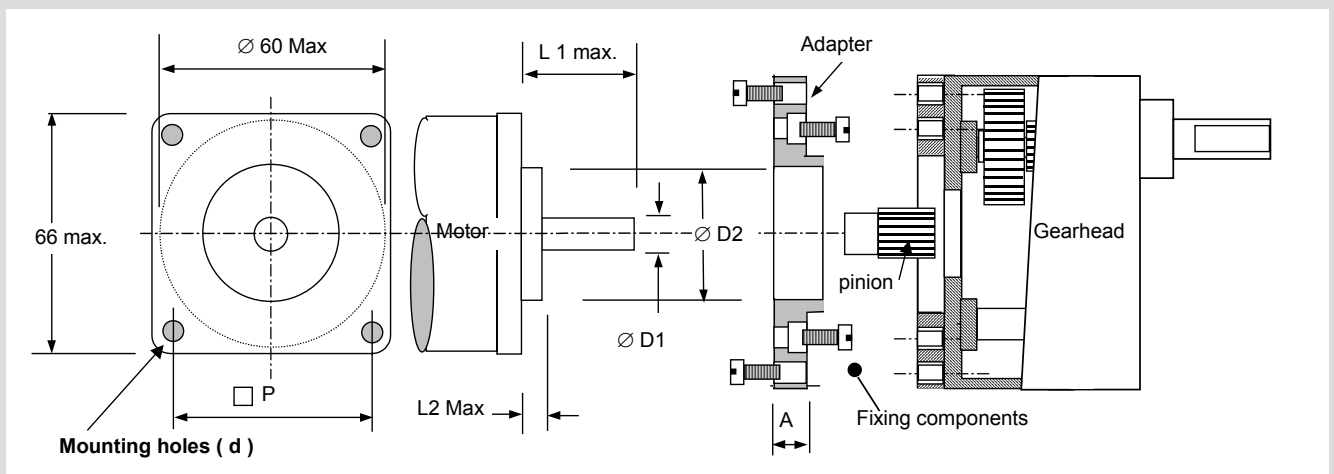

Fitting the pinion to the motor

A : The pinion is positioned motor shaft as shown

Note : The dimension 12.5 mm is the distance from the mounting face of the motor or the adapter when used. Retain using Loctite 638

B: Mount the motor to the rear plate of the gearbox using the appropriate set of tapped mounting holes

Pinion Options:

Order Code

Bore Diameter

mm

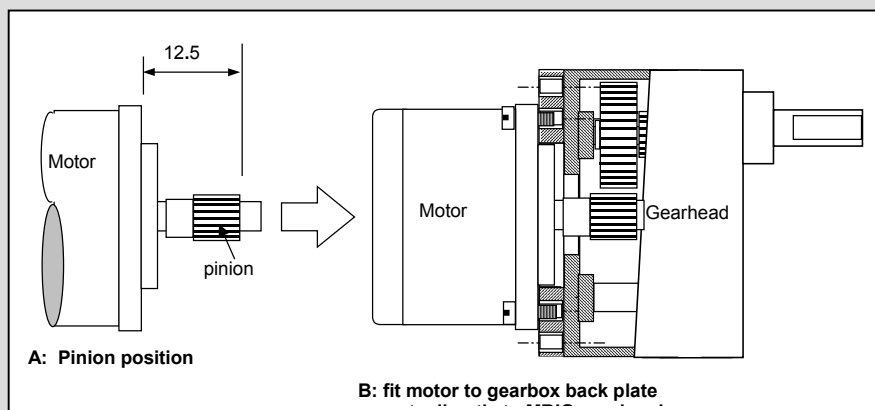

202GMP00015	3
202GMP00016	4
202GMP00017	5
202GMP00018	6
202GMP00019	6.35

Standard adapter options for motors with round flanges:

Dimensions mm

Adapter		204ADT03372	204ADT00033	204ADT00033
Adapter thickness	A	3.5	7	7
Motor details				
Mounting holes	d	4 x M3	3 x M4	4 x M4
Mounting hole PCD	PCD	28	50	38.89
Motor register diameter	∅ D2	18	28	25
Max register length	L2			
Suitable motors		9904 120 15 9904 120 16	M66 Series BLDC58	M540 M586
Special fitting tool required		None	None	204MSC00002

Standard adapter options for motors with square or two point fixing flanges:

Adapter		204ADT00005	204ADT00002	204ADT03678
Adapter thickness	A	3.5	N / A	4.5
Motor details				
Mounting holes	d	2 x M3 studs or 4 x M3	2 x 4.4 or 4 x 4.4	4 x M4
Distance between centres	P	31	56 or	
Mounting hole PCD	PCD		66.6	40
Motor register diameter	∅ D2	22	12	25
Max register length	L2	2	1.6	6
Suitable motors		17HS series	9904 111 35 9904 112 35 9904 111 36 9904 112 36 MV82 series MV86 series	M1440 Pittman (round motor flange converted to square using adapter shown)
Special fitting tool required		None	None	None