

Rack Mounting Power Supplies

MSE Series

MSE & PM series power supplies have been developed specifically for motor drive applications. The output characteristics are ideally suited to stepper & servo motor drive applications. The high voltage units are provided with an auxiliary dc logic supply for use with high voltage drives and associated PM600 series controllers. MSE series power supplies are designed to be mounted in standard 19in x 3U high rack systems.

PM series are supplied as 19 in. by 3U high racked units with sufficient space alongside the power supply to fit additional drive and control modules to provide a self contained drive system.



dimensions: mm

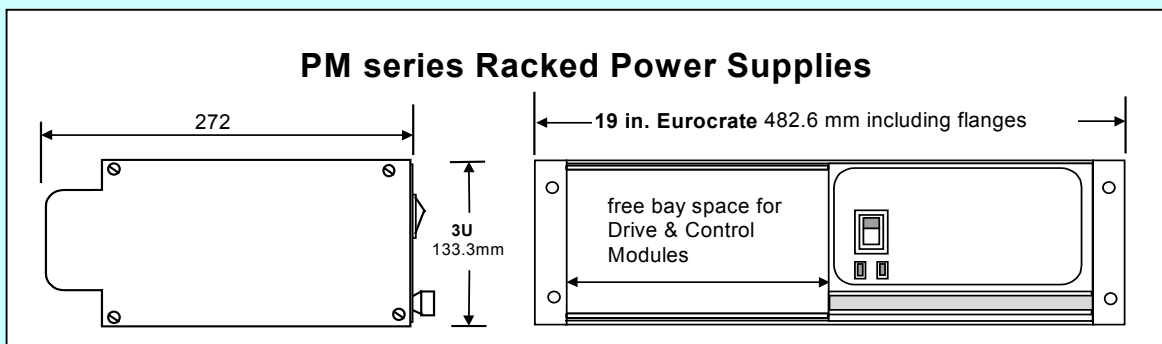
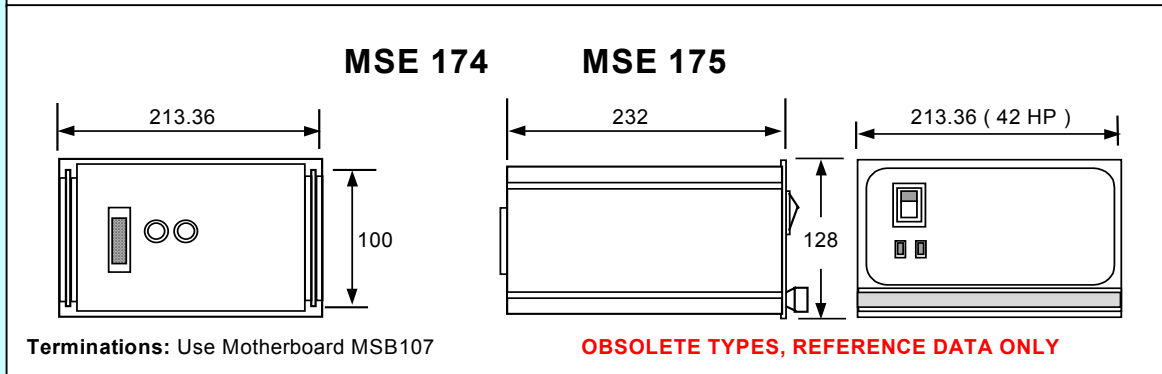
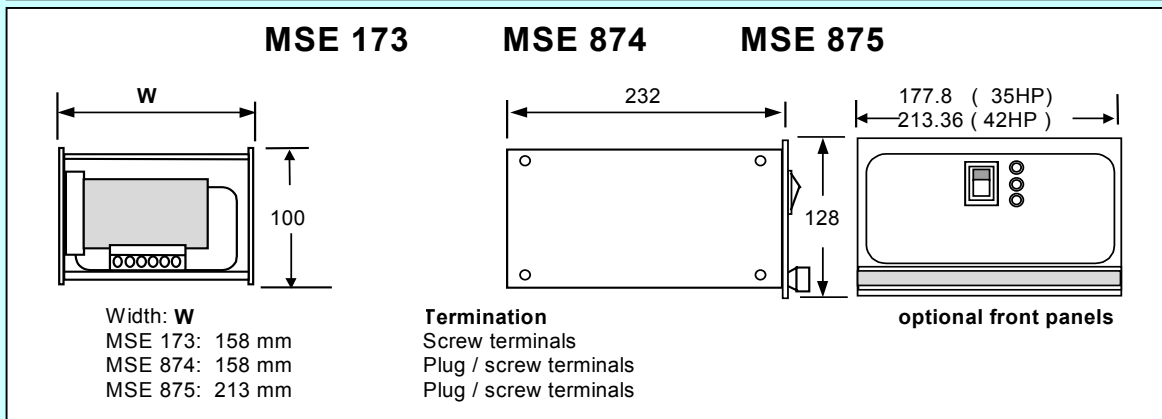
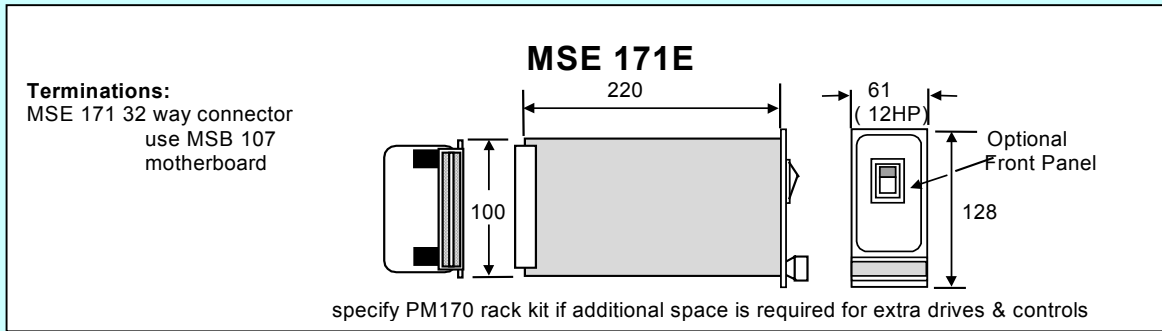

Rack Mounting Power Supplies

MSE Series

Specification

Suitable supplies, models MSE17X series: 220, 240 Vac-50 or 60 Hz. MSE874, MSE875: 115, 230 Vac-50 or 60 Hz.
Output characteristics:

MODULAR POWER SUPPLY TYPES RACKED POWER SUPPLY VERSIONS Front Panel, Switch & fuse kit	MSE171 PM 171 FP12-PSU	MSE173 PM 173 FP35-PSU	MSE174 PM174 standard	MSE874 PM 874 FP35-PSU	MSE175 PM175 standard	MSE875 PM 875 FP42-PSU
Total Power Capacity (Watts)	72	288	380	400	420	570
Output voltage @ no-load (Vdc)	32	28	54	55	74	83
Output voltage @ full load (Vdc)	27	24	46	48	66	74
Voltage tolerance (±Vdc)	1.5	1.0	3.0	3.0	3.0	3.0
Max peak / peak ripple (Vdc)	3.0	2.6	4.8	4.2	4.8	7.6
Full load current (Amps)	3.0	12	8.0	8.0	6.0	6.0
Over current capacity for 1 sec. (Amps)			16	16		12
Secondary motor supply						
Output voltage @ no-load (Vdc)						46
Output voltage @ full load (Vdc)						40
Voltage tolerance (±Vdc)						3.0
Max peak / peak ripple (Vdc)						3.8
Full load current (Amps)						8.0
Over current capacity for 1 sec. (Amps)						20
Auxiliary logic supply (Vdc)	**	**	18	24	18	24
Logic supply current rating (Amps)	**	**	2	2	2	2
Note ** Use 24 Vdc motor rail as req'd.						
Suitable Stepper motor Drives Depending on number of axes	MSE422 PM542 PM570	MSE422 PM542 PM570	PM546	PM546	PM546	PM546 PM570 MSE422
Suitable Servo motor Drives Depending on number of axes	PM421	PM421 PM810	PM810	PM810		PM810 PM421

Typical installations:

The combination of drive and controller together with a suitable PM series racked power supplies enables a wide range of single & multi-axis motion systems to be readily constructed.

Furthermore, a motherboard is available for each drive module to enable connections to be made via solder-free screw terminals. The motherboard is fitted to the rear of the PM series racked power supply unit.

(Illustration shows PM174 Racked power supply with optional top / bottom ventilated covers)



Typical drive, controller & recommended power supply combinations:

24 Vdc systems: Maximum power capacity: 72 Watts

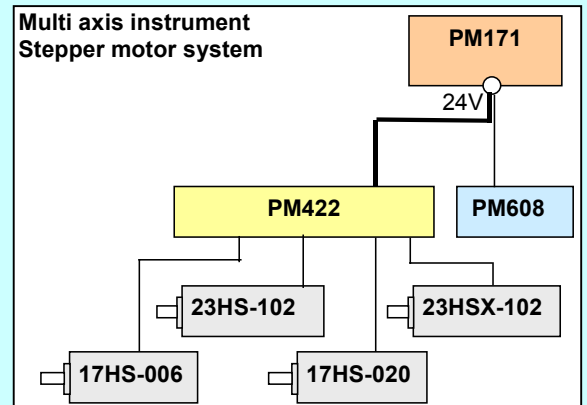
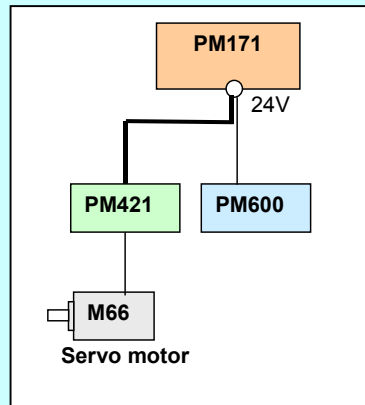
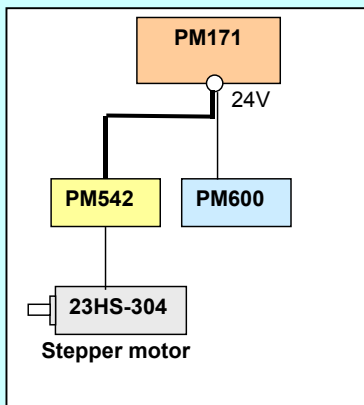

Typical drive, controller & recommended power supply combinations:

24 Vdc systems: Maximum power capacity: 288 Watts

Stepper motor system

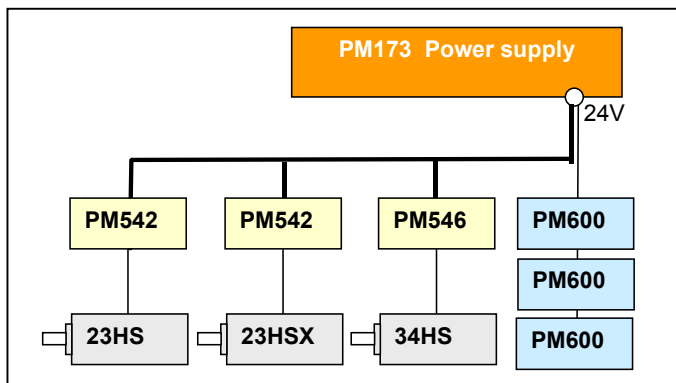

Servo motor system

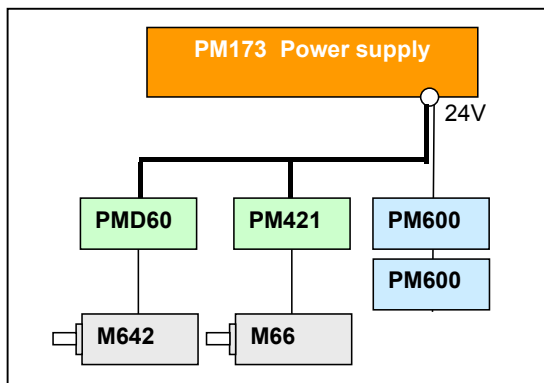

Typical hybrid system using stepper & servo

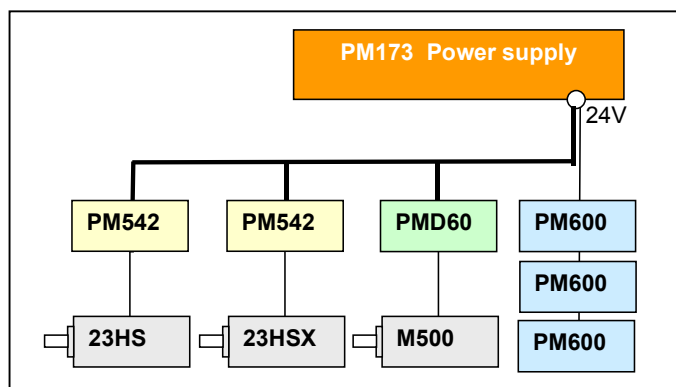

Typical mounting in Eurorack enclosures

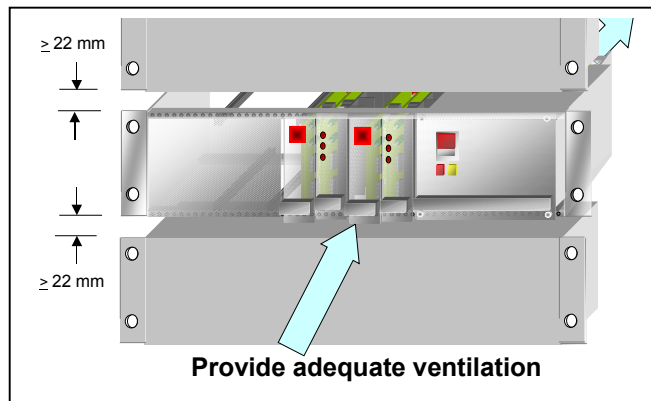

48 Vdc systems: Maximum power capacity: 400 Watts

Stepper motor system

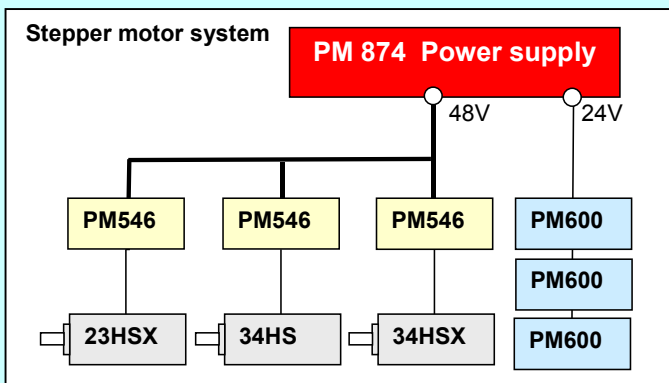

Servo motor system

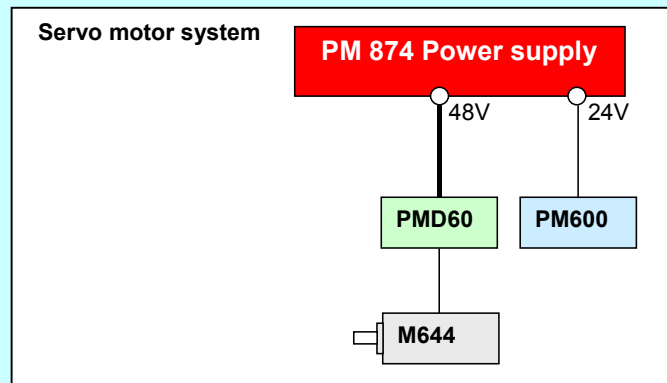

Stepper / servo motor systems

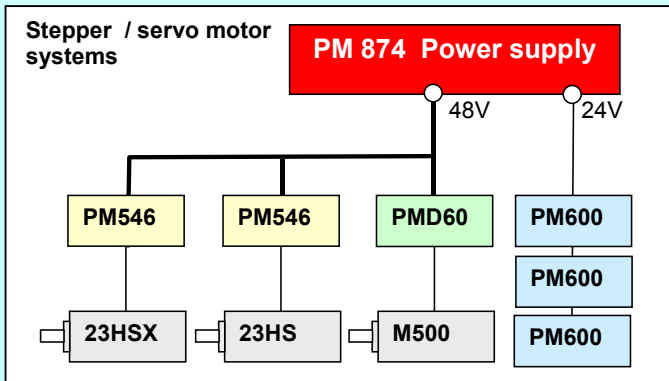

Servo motor systems

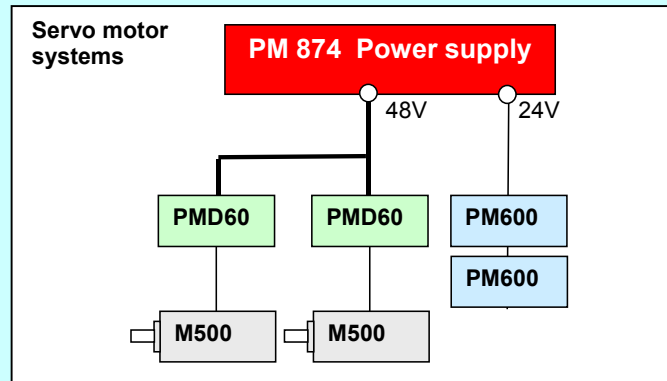

Rack Mounting Power Supplies

MSE Series

Typical drive, controller & PM875 power supply combinations:

The provision of a multi-rail output enables a wider range of drives, providing optimum motor performance, to be connected to a single power source with a consequential saving in cost and rack space

70 / 40 Vdc systems: Maximum power capacity: 500 Watts

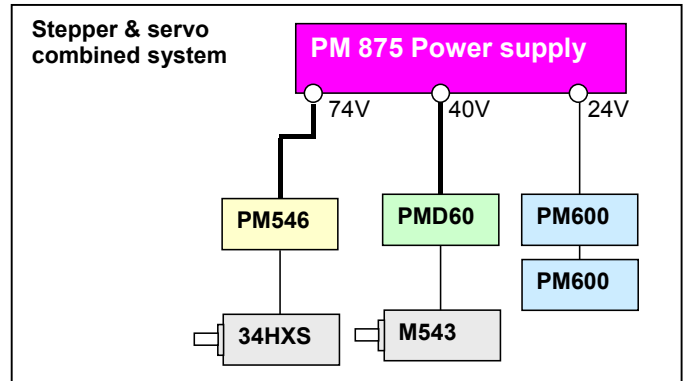
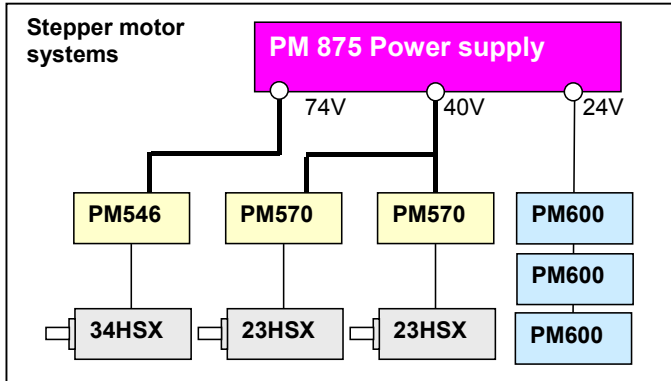

Guidelines to power supply selection

- Based on drives required, select a power supply ensuring that it's output does not exceed the drive's input capability. Note maximum motor performance is obtained when the drive is operated at full voltage.
- Ensure that the total power capacity requirement of the drives selected does not exceed the power supply capacity. To determine the current consumption and hence the power capacity requirement of each stepper motor drive the data for that drive should be consulted.
- Ensure that the total current consumption for each supply rail is not exceeded and that the total power requirement does not exceed the power capacity of the power supply unit
- Ensure that the total module width of the selected combination of modules does not exceed 84HP.

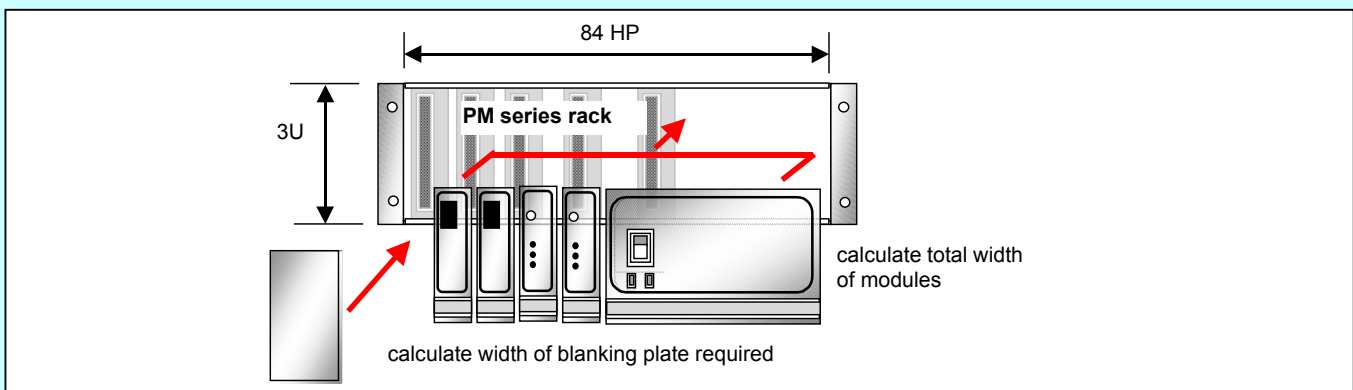

Module panel widths

Stepper drive modules		Servo Drive modules		Controllers		Power Supplies	
Module	Width	Module	Width	Module	Width	Module	Width
PM422	7HP	PM421	12HP	PM600	7HP	MSE171	12HP
PM542	7HP	PMD60	12HP	PM608	14HP	MSE173	35HP
PM546	7HP			PM610	21HP	MSE874	35HP
PM570 classic	12HP					MSE174 / 5	42HP
PM570 Evo 2	7HP					MSE875	42HP

Example: PM875 Rack (utilising MSE875 modular power supply) : 42 HP
 Fitted with 2 pieces PM546 @ 7HP wide total 14 HP
 2 pieces PM600 @ 7HP wide total 14HP
 Total 70HP,
 Blanking panel required: 14HP