

Mclennan Servo Supplies Ltd.

Mclennan

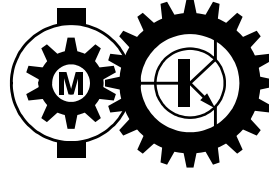

Quad Axis Bipolar Stepper Motor Translator

User Handbook

MSE422

Mclennan Servo Supplies Ltd.
Unit 1, The Royston Centre
Lynchford Road
Ash Vale
GU12 5PQ UK

Telephone: +44 (0)8707 700 700
FAX: +44 (0)8707 700 699

E-mail: sales@mclennan.co.uk
tech@mclennan.co.uk



MSE422 Data Sheet

Quad Axis Bipolar Stepper Motor Translator

- Four translators on a single card.
- Each translator is independent.
- Up to 600mA current output per phase.
- Half or full step sequence selectable by on board switch.
- On board current select switches.
- Alternative external current control.
- Current reduction and current off control inputs.
- Operates from 10V to 30V DC single rail supply.
- MSB423 motherboard available for easy installation.

OUTPUTS

For each of the four translators, there are chopped, constant current, outputs for both phases of a bipolar stepper motor.

The motors coil winding 1 should be connected between phase1 and phase1'. The motors coil winding 2 should be connected between phase2 and phase2'.

CONTROL INPUTS

There are four digital control inputs for each translator. These inputs are pulled up to 5V on board and have schmitt trigger input buffers. They are as follows:

CLK	CLOCK	Each time this input is pulled low, the stepper motor will advance one step in the required direction.
DIR	DIRECTION	This input selects the direction the stepper motor will move.
PWRDN	POWER REDUCTION	Pulling this input low will reduce the output current of both phases to approximately 20% of the selected value. This facility may be used to avoid excessive motor heating by only applying holding torque to a motor.
MIOFF	MOTOR CURRENT OFF	Pulling this input low will remove the output current of both phases of the motor.

ON BOARD DIP SWITCHES

For each translator, there is a DIP switch to set up its parameters. The switch for axis 1 (SW1) may be found at the centre of the board, at the top. The switches for axes 2, 3 and 4 (SW2, SW3 and SW4 respectively) are below it.

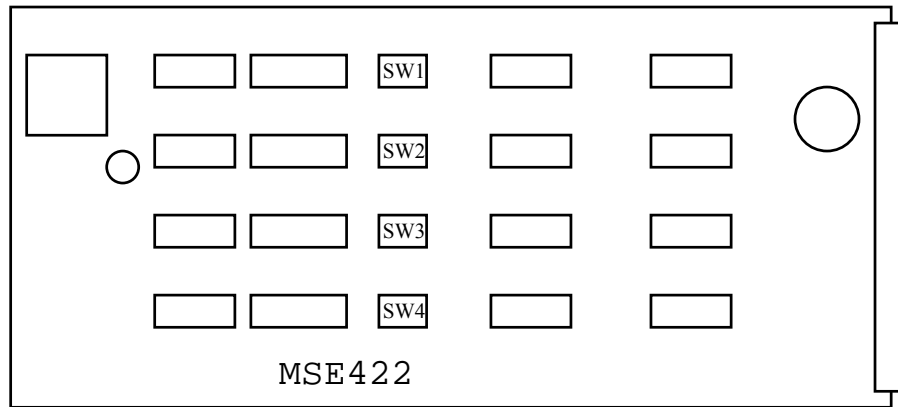

Element 1 of each switch (closest to the boards connector) is used to select the step size and the other switch elements are used to select the current per phase.

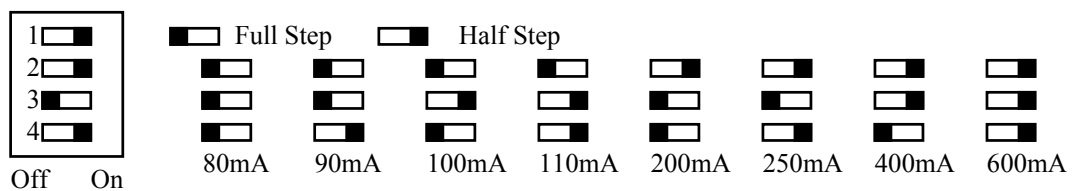

The above values are nominal.

EXTERNAL CURRENT CONTROL

If required, the output current may be set by an external potentiometer. A 10KΩ pot may be connected between the external current control signal XC1 and 0V, with the wiper connected to XC2. The on board current control switches should be switched **OFF**. The relationship between the pot position and the output current is approximately linear, and will vary between 0 and 560mA.

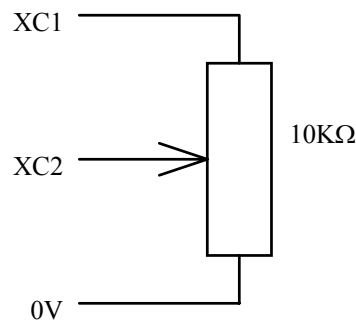

EXTERNAL CONNECTIONS

Power Supply connections.

+VMM	1-2a&b	Supply 10V - 30V DC	Unregulated supply.
0V	31-32a&b	Supply 0V	

Motor Output connections.

	Axis 1	Axis 2	Axis 3	Axis 4
Phase 1	3a&b	7a&b	11a&b	15a&b
Phase 1'	4a&b	8a&b	12a&b	16a&b
Phase 2	5a&b	9a&b	13a&b	17a&b
Phase 2'	6a&b	10a&b	14a&b	18a&b

Control input connections.

	Axis 1	Axis 2	Axis 3	Axis 4
CLK	19a	22a	25a	28a
DIR	19b	22b	25b	28b
PWRDN	20a	23a	26a	29a
MIOFF	20b	23b	26b	29b

External Current Control connections.

	Axis 1	Axis 2	Axis 3	Axis 4
XC1	21a	24a	27a	30a
XC2	21b	24b	27b	30b

WE RECOMMEND THE USE OF THE MSB423 MOTHERBOARD TO FACILITATE CONNECTIONS.

Ensure this unit is mounted to allow adequate airflow for cooling of the power devices. When using high current settings, it may be necessary to use forced air cooling.