

Mclennan Servo Supplies Ltd.



TM 9122

Micro-step Drive
User Manual

USER'S MANUAL FOR **TM9122 Micro-step Drive****SAFETY NOTICE !**

Position control systems are inherently hazardous. Even a small motor, if coupled to a leadscrew, gearbox, or any other form of mechanism that provides a mechanical advantage, can generate considerable force and could cause serious injury. Incorrect operation can also lead to damage to the motor or associated machinery.

**Caution****STATIC SENSITIVE DEVICES**

This unit has static sensitive devices. Observe handling precautions: Hold card by edges only. Do not touch connector pins. Ship only in anti-static packaging.

Mclennan Servo Supplies Ltd.
Unit 1, The Royston Centre
Lynchford Road,
Ash vale,
GU12 5PQ

Telephone: +44 (0)8707 700 700
FAX: +44 (0)8707 700 699
Sales EMAIL: sales@mclennan.co.uk
Technical EMAIL: tech@mclennan.co.uk

The manufacturer reserves the right to update the data used in this manual in line with product development without prior notice.

CONTENTS

1 INTRODUCTION 3

2 TECHNICAL SPECIFICATION 4

2.1 SYSTEM DATA 4

2.2 CONNECTION DATA 4

3 SET-UP 6

3.1 SET-UP SWITCHES 6

3.2 CURRENT SETTING 7

3.3 DRIVING MODES 7

3.4 CURRENT BOOST FACTOR 9

3.5 CURRENT REDUCTION 9

3.6 STEPPING ANGLE 10

4 SYSTEM CHARACTERISTICS 11

4.1 SHORT CIRCUIT PROTECTION 11

4.2 OVERHEAT PROTECTION 11

4.3 OVER-VOLTAGE PROTECTION 11

4.4 MICRO-STEP CHARACTERISTICS 12

4.5 APPLICATION OF SUPPLY VOLTAGE 12

5 CONNECTING THE STEPPER MOTOR DRIVES 13

5.1 CONNECTION DIAGRAMS 14

6 MECHANICAL INSTALLATION 15

6.1 ELECTRICAL CONNECTOR 15

6.2 INSTALLATION GUIDELINES 15

6.3 DIMENSIONS 15

1 Introduction

The bipolar TM9122 stepper motor driver is a chopping amplifier for driving two or four phase motors. Various advantageous features make these units into universal components for stepper motor drive systems. The main features are:

- Programmable stepping angles from 1/10 to 15/10 of full step. This enables the stepping resolution to be matched to each individual application on the one hand, while resulting in practically resonance free rotation with the so-called micro-step resolution (1/10, 2/10, etc.) on the other hand.
- Automatic current reduction at standstill can be selected. In this way, unnecessary heating of the motor can be avoided.
- Boost current control up to a factor of 2.75 of the set value which allows the drive power to be optimised, e.g. during the acceleration and running phases.
- Display of system alarms caused by short circuits, overheating or overvoltage; automatic reset implemented. This means that drivers are optimally protected against external influences.
- Only one unstabilised supply voltage of 18...60V dc is needed. Complicated and therefore expensive power supply units are not required.
- Universal control inputs suitable for use with all commonly used industrial signal voltage levels. Any signal source can thus be connected directly without interface circuitry.
- All the necessary setting are made by means of onboard switches so that time consuming setting up and adjustment procedures can be dispensed with.

2 Technical Specification

2.1 System Data

Type of drive	Bipolar
Nominal current per phase	5A
Peak current per phase.....	7A
Current reduction at standstill	50%
Boost current factor.....	1 to 2.75
Supply voltage range.....	18...60V dc
Nominal supply voltage	48V dc
Control signal voltage	3.5 to 6V dc or 10 to 30V dc
Max stepping frequency	>100kHz
Chopping frequency	>20kHz typ.
Stepping angle.....	1/10 to 15/10 of full step
Dimensions.....	100x160x91 mm
Max. ambient temperature.....	50°C
without forced-air cooling	

2.2 Connection Data

Supply Voltage

Max. ripple	5%
Peak value	<60Vdc, >18Vdc
Smoothing capacitor.....	5000µF min. per motor

Pulse input

Step reaction.....	Input current sourcing
Pulse/interval duration	5µS min.
Rise/fall time	0 to 1mS max.

Direction input

Min. waiting time for pulse after change of direction.....	500µS
Min. waiting time for change of direction after pulse.....	50µS
Rise/fall time	0 to 1mS max.

Connection Data continued:

Windings off input

Motor windings current-less Input - current sourcing
 Reaction time..... <500µS

Note:

The stepper motor is always driven to a predefined basic phase state after a *windings off* signal is removed.

Boost-on input

Boost activated Input - current sourcing
 Reaction time..... 2mS

+10V logic voltage

The internal +10V logic voltage is brought out to pin 8c via a resistor. This should be used exclusively for measurement purposes.

3 Set-up

3.1 Set-up switches

There are three 16 position encapsulated rotary switches on the circuit board for setting the motor current and the current boost factor as well as the stepping angle.

Position	Switch I Current (A)	Switch B		Switch S Full Step
		Boost Factor FB	Current Reduction	
0	0.5	1.00	no	0
1	0.8	1.25	no	1/10
2	1.1	1.50	no	2/10
3	1.4	1.75	no	3/10
4	1.7	2.00	no	4/10
5	2.0	2.25	no	5/10
6	2.3	2.50	no	6/10
7	2.6	2.75	no	7/10
8	2.9	1.00	yes	8/10
9	3.2	1.25	yes	9/10
A	3.5	1.50	yes	10/10
B	3.8	1.75	yes	11/10
C	4.1	2.00	yes	12/10
D	4.4	2.25	yes	13/10
E	4.7	2.50	yes	14/10
F	5.0	2.75	yes	15/10

3.2 Current Setting

The phase current can be set-up to the required value by means of switch **I**. The current is generally set to the nominal rating of the motor in use. A lower current can however be set if the motor is not going to be fully loaded. The ideal setting in such cases is best found by practical experimentation. The smallest practicable current should always be selected to achieve the smoothest possible running.

The nominal current rating for a motor is normally given on its type label. The rating given is understood to mean the current per half winding for two-phase motors (six connections) and to mean the current per winding for four-phase motors (eight connections).

3.3 Driving Modes

The TM9122 is a bipolar driver, therefore two-phase or four-phase stepper motors can be driven in various modes. The appropriate drive current has to be set-up to suit the driving mode as shown in the following table.

MODE	CONNECTION	CURRENT SETTING
	Two-phase stepper motors	
1	Only one winding half:	nom. phase current
2	Both winding halves:	nom. phase current $\div \sqrt{2}$
	Four-phase stepper motors:	
3	Only one winding:	nom. phase current
4	Both windings in series:	nom. phase current $\div \sqrt{2}$
5	Both windings in parallel:	nom. phase current $\times \sqrt{2}$

Various torque characteristics result depending on the manner (1...5) in which the two-phase or four-phase motors are connected.

Windings connected in series produce a high torque at low speed and a low torque at high speed. Singly connected windings give a low starting torque but a high torque at higher speeds. Parallel connected windings produce a good torque over the whole speed range.

Driving Mode 1

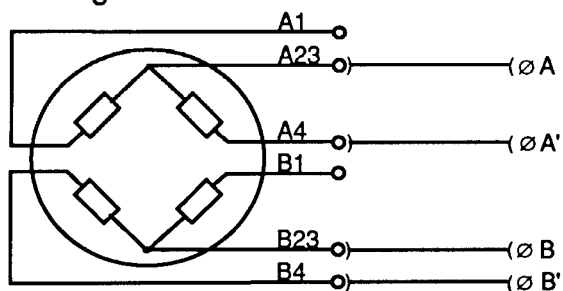

Driving Mode 2

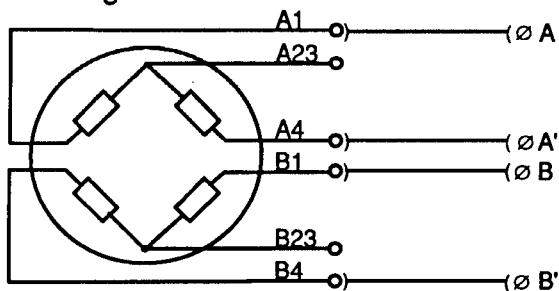

Driving Mode 3

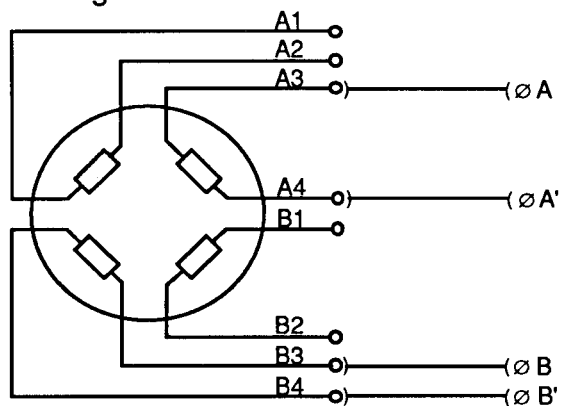

Driving Mode 4

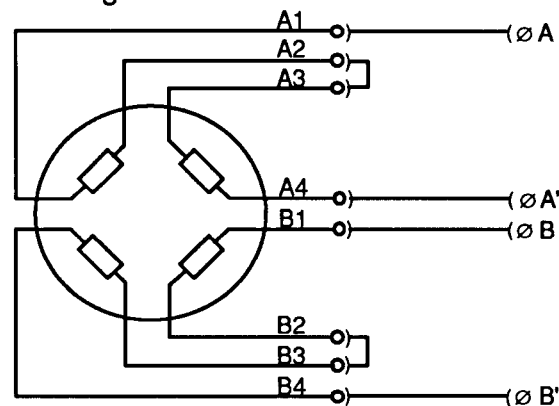

Driving mode 5

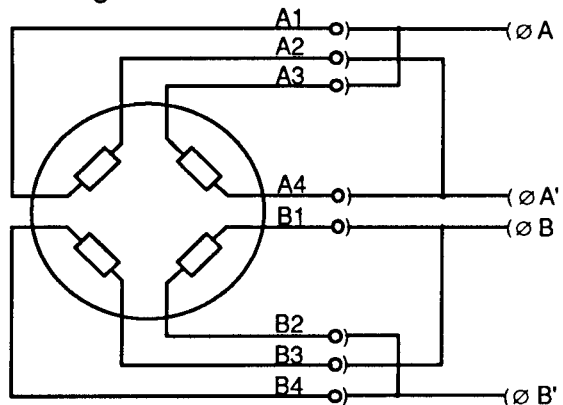

3.4 Current Boost Factor

The torque of a stepper motor varies as a function of the current flow in the windings. Provided that the stator of the motor is not magnetically saturated, the torque increases more or less in proportion to the phase current. This property can be exploited with the *boost* signal. The phase current (I_{ph}) is increased as long as this signal is present. The resultant boosted current (I_b) is the product of the boost factor (FB) times the set phase current (I_{ph}) i.e. ($I_b = I_{ph} \times FB$). It should be noted however, that the maximum boost current is 5A.

Example:

The phase current has been set to 2.0A and the boost factor has been set to 1.75. As long as the boost signal is active, the phase current is increased from 2.0A to 3.5A.

The following points must be strictly observed when using the boost factor:

1. The boosted current, I_b , must not exceed the maximum permissible phase current for the stepper motor otherwise there is a danger of the permanent magnets becoming demagnetized.
2. If the motor is supplied with boosted current for a long time, there is a danger of the motor overheating and being destroyed.

3.5 Current Reduction

A motor which is supplied with its nominal phase current whilst at standstill is often destroyed by the resulting heating effect. In most cases the holding moment of the motor is not fully used and it may therefore be supplied with a reduced phase current to prevent unnecessary heating. The switch **B** on the TM9122 Driver enables not only the current boost factor to be set but also the current reduction factor.

The current reduction feature is inactive in switch positions 0 to 7 and active from position 8 up to position F.

When the reduction feature is active, the phase current is reduced to 50% of the set value about 2 seconds after the last pulse.

3.6 Stepping Angle

Conventional stepper motor drivers usually operate in the so called full-step and/or half-step mode. The stepper motors used for industrial applications usually have a stepping angle of 1.8° . In full-step operation such motors therefore have a resolution of 200 steps/revolution and in half-step the resolution is 400 steps/revolution. Clearly, the large steps are a disadvantage concerning resolution and smoothness. To overcome this problem the TM9122 stepper motor drive offers the possibility of the *micro-step* technique. In this mode the phase current is regulated so that fractions of a full-step (micro-steps) can be generated. The actual stepping angle produced by a *micro-step* is adjustable by means of switch **S** over the range 1/10 to 15/10 of a full step.

The following stepping angle settings are of practical interest for motors designed for 200 steps per revolution:

10/10 = 200	steps/rev	= 1.8° per step
8/10 = 250	steps/rev	= 1.44° per step
5/10 = 400	steps/rev	= 0.9° per step
4/10 = 500	steps/rev	= 0.72° per step
2/10 = 1000	steps/rev	= 0.36° per step
1/10 = 2000	steps/rev	= 0.18° per step

Care should be taken in choosing a *position controller* to ensure that it is capable of producing the higher frequencies involved when small micro-steps are required. For example, the frequency is 10 times higher with 1/10 micro-steps than with full-steps (10/10) to achieve the same number of revolutions.

Example:

A stepper motor with a 1.8° stepping angle has to be positioned at a rate of 2400 rpm. What stepping frequency will be necessary in the full-step, half-step and 1/10 micro-step mode?

2400 rpm divided by 60 = 40 rev/sec

1 full-step (10/10) = 360° divided by 1.8° = 200 steps/rev
 Stepping frequency = 40 rev/sec x 200 steps/rev
 = 8000 steps/sec (8kHz)

1 full-step (5/10) = 360° divided by 0.9° = 400 steps/rev
 Stepping frequency = 40 rev/sec x 400 steps/rev
 = 16000 steps/sec (16kHz)

1 full-step (1/10) = 360° divided by 0.18° = 2000 steps/rev
 Stepping frequency = 40 rev/sec x 2000 steps/rev
 = 80000 steps/sec (80kHz)

4 System Characteristics

4.1 Short Circuit Protection

The TM9122 Stepper Motor Driver is protected against the following short circuits at the motor outputs:

1. A short between related motor connections (A and A' or B and B') e.g. caused by a winding short.
2. A short between non-related motor connections (A or A' and B or B') e.g. crossed-over windings.
3. Short between motor connections and 0V of the supply (A, A' B or B' and 0V) i.e. a short to ground.

A short circuit activates the output and the *system-alarm* LED. If the short circuit is between related motor connections then the set phase current continues to flow. In all other cases the phase current is switched off.

The *system-alarm* is automatically reset 2 seconds after a short circuit has been removed and the phase current is reinstated again as appropriate.

4.2 Overheat Protection

A temperature sensor attached to the heatsink of the TM9122 Stepper motor drive protects the units from thermal destruction. The *system-alarm* is activated and the phase current is switched off when the temperature of the heatsink rises above 110°C

The temperature sensor is sampled every two seconds to determine whether the temperature has sunk below the critical threshold level so that the *system-alarm* can be reset and the phase current can be switched on again. The maximum ambient temperature can be up to 50°C with the unit running at full load without forced-air cooling.

4.3 Over-voltage Protection

TM9122 Stepper motor drives are protected against an excessive supply voltage. As soon as the supply voltage rises above the maximum permissible level of 60V dc, the phase current is switched off and the *system-alarm* is activated. The *system-alarm* is reset two seconds after the supply voltage has sunk below the maximum level again.

When using unstabilised power supplies, care must be taken to ensure that besides the (measured) effective value, the peak values of voltage also lie below the maximum permissible level.

4.4 Micro-step Characteristics

For the user the micro-step technique means smooth running (with practically no resonance) and high resolution using commercially available stepper motors. The stepping angle tolerances in the micro-step range depend on various factors such as:

- Quality of the stepper motor
- Quality of the current regulation through the driver
- Phase current in the stepper motor

When using high quality stepper motors with a phase current equal to or less than the nominal rating, a maximum stepping angle tolerance of $\pm 1/10$ of a micro-step can be expected at the rotor shaft in the unloaded state.

Greater tolerances can occur if the motor is driven with phase currents in excess of the nominal value (note the connection mode)!

4.5 Application of Supply Voltage

The stepper motor is always driven to a predefined basic phase state when the supply voltage is applied or after the *windings off* signal has been removed.

The alarm LED lights-up for about two seconds after the supply voltage has been switched on.

5 Connecting the Stepper Motor Drives

All the signal inputs and outputs are electrically separated by means of opto-isolators.

Each input is provided with connections for 3.5...6V, 10...30V and 0 (negative) so that as many commonly used industrial signal levels as possible including positive-going and negative-going sources can be handled. All inputs are protected against reverse polarity.

The *system-alarm* has an open-collector output transistor.

It is recommended to use screened, twisted-pair connections to the motor if the length of the cable exceeds 3 to 4m. The following points should be observed if the cables are going to be made by the user.

- Each connection to a winding (2 wires) should be separately twisted.
- There should be a crossover about every 5cm.

5.1 Connection diagrams

Input currents:

3.5...6V:..... $I_{in} \leq 10\text{mA}$
 10...30V:..... $I_{in} \leq 14\text{mA}$

Input delay:

Pulse: $T_d < 10\mu\text{S}$
 Boost: $T_d < 2\text{mS}$
 Other inputs:..... $T_d \leq 0.5\text{mS}$

System alarm output rating:

$I_a \text{ max.} : \dots\dots\dots 15\text{mA}$
 $V_a \text{ max.} : \dots\dots\dots 30\text{V}$
 Voltage drop:..... 0.4V max.

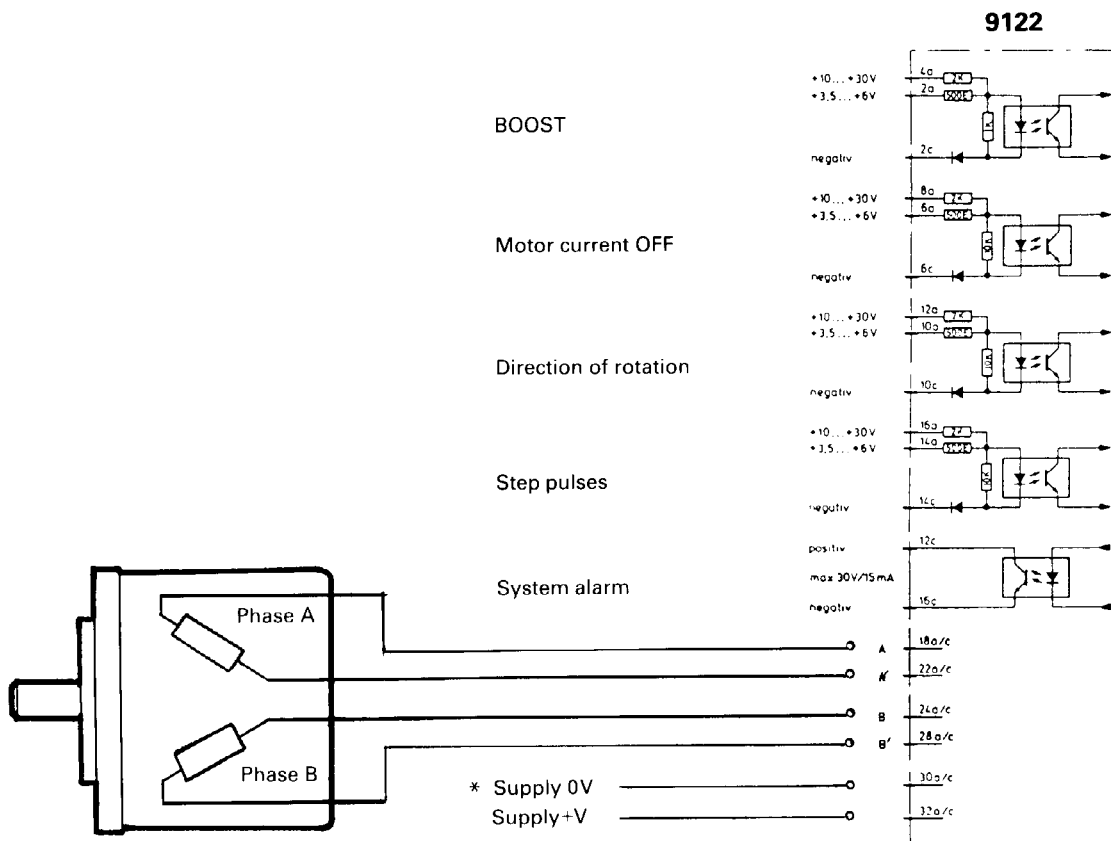

6 Mechanical Installation

The TM9122 Stepper Motor Drivers are modular devices built in the Euro-card format. They consist of a logic section and a power section with a heatsink. An MSB109 backplane may be used for installation in a control rack.

6.1 Electrical Connector

The connector use has a 4A rating.
The type is DIN 41612 32AC type D.

6.2 Installation guidelines

The Stepper motor Drivers must be installed vertically to ensure sufficient heat dissipation from the heatsink even under full load conditions if they are to be used without forced air cooling. Sufficient space must also be left free above and below the module to permit good air circulation.

The following minimum distances should be kept between TM9122s and other modules:

- Above: approx. 15mm
- Below: approx. 15mm
- Sideways: approx. 15...20mm

6.3 Dimensions

