

Dimensional drawing

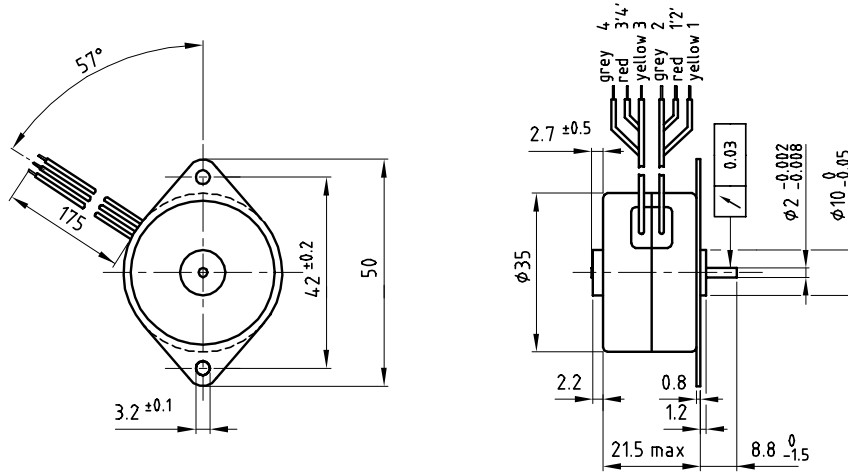

Motor data

Motor order number	9904 112 +	32101	32001
Number of phases		4	4
Drive Electronics		Unipolar	Unipolar
Nominal Voltage	[V]	5	12
Number of steps per revolution		48	48
Step angle	[°]	7.5	7.5
Step angle tolerance	[°]	± 0.7	± 0.7
Max. working Torque	[mNm]	7.5	6
Holding Torque	[mNm]	10	10
Absorbed power	[W]	2	2
Resistance per phase	[Ohm]	21	120
Inductance per phase	[mH]	30	160
Current per phase	[mA]	220	100
Thermal resistance winding-ambient	[K/W]	25	25
Rotor Moment of Inertia	[kgm ²]	0.26x10 ⁻⁶	0.26x10 ⁻⁶

Electrical Connection

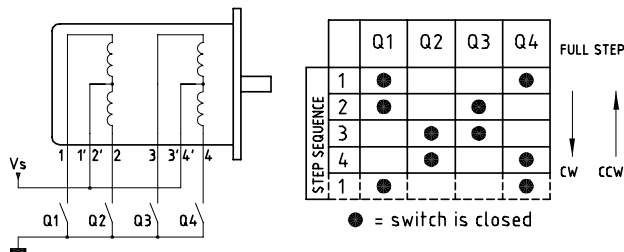

General data

x	Type of bearings	sleeve	
x	Maximum radial load	2.5	N
x	Maximum axial load	0.75	N
x	Ambient temp. range operating	-20/+70	°C
x	Ambient temp. range storage	-40/+100	°C
x	Mass of motor	80	g

Product combinations

- x Gearbox S49A
- x Gearbox S52A
- x Gearbox S70A