

Precision planetary gearheads

HP series



- Standard integer gear ratios from 4;1 to 100:1
- Low backlash of typically ≤ 6 arc minutes for high positioning repeatability
- Reduced backlash options down to ≤ 2 arc minutes for increased precision
- Choice of industrial standard frame sizes from 60 to 180 mm diameter
- High torque capacity from 31 to 1200 Nm suitable for rapid positioning systems
- 250% Emergency overload capacity for increased protection
- Pure planetary design for smooth operation & reduced vibration
- Improved *Easyfit* motor mounting for a wide range of motors
- Alternative double shaft versions

Precision planetary gearheads

HP series

The HP series planetary gearheads are designed to meet the demanding requirements of high performance servo systems and provide a combination of high torque and low backlash necessary for high speed positioning. This is achieved by a commitment to manufacturing efficiency combined with optimum design that maintains high reliability & quality. The units are suitable for use with a wide range of stepper, dc servo or brushless servo motors using a comprehensive range of standard motor mounting flanges and an *Easyfit* shaft clamp design.

HP gearheads are the ideal choice in industrial automation, robotics, machine tool, laser cutting, test and & measurement machinery as well as scientific apparatus.



Key features

- Standard integer gear ratios from 4:1 to 100:1
- Low backlash of typically ≤ 6 arc minutes for high positioning repeatability
- Reduced backlash options down to ≤ 2 arc minutes for increased precision
- Choice of industrial standard frame sizes from 60 to 180 mm diameter
- High torque capacity from 31 to 1200 Nm suitable for rapid positioning systems
- 250% Emergency overload capacity for increased protection
- Pure planetary design for smooth operation & reduced vibration
- Improved *Easyfit* motor mounting for a wide range of motors (specify –'B' versions)
- Alternative double shaft versions (specify –'C' versions)
- Rapid delivery
- Economic pricing

High precision construction using caged planetary gear design

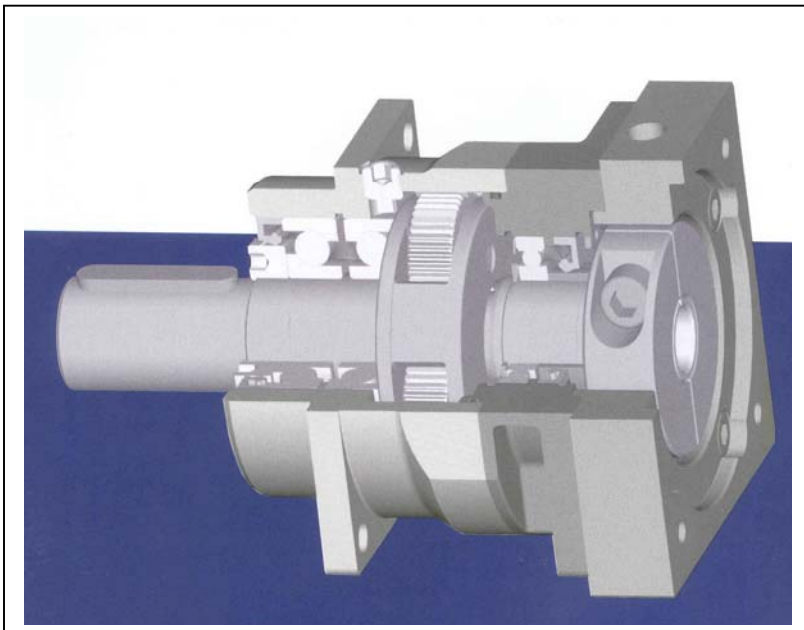

The HP gearhead construction provides optimum strength combined with precision.

The annular teeth are precision cut in the gearhead housing for optimum strength & smooth running over a wide temperature range while the planetary gears are mounted on precision needle bearings and supported in a carrier cage for increased strength

The input motor flange utilises a precision register to enable the motor to be accurately aligned while the split input clamp provides optimum torque transmission.

Single stage units: Output Characteristics

HPS series

Gearhead	Ratio	Continuous Torque Nm	Peak Torque Nm	Emergency Torque Nm	Standard Backlash arc min.	Reduced Backlash arc min.	Torsional Rigidity Nm/arc min.	Max Radial Load N	Max Axial Load N
HPS60	4:1	26	35	90	≤ 6	≤ 4	≥ 5	2000	2000
	5:1	30	38	90					
	7:1	23	31	90					
	10:1	18	34	85					
HPS75	4:1	60	79	190	≤ 6	≤ 4	≥ 8	2500	2500
	5:1	63	75	190					
	7:1	65	79	190					
	10:1	45	60	150					
HPS100	4:1	180	248	575	≤ 3	≤ 2	≥ 23	4000	4000
	5:1	180	240	575					
	7:1	178	220	575					
	10:1	144	204	500					
HPS140	4:1	348	432	1050	≤ 4	≤ 3	≥ 68	7500	7500
	5:1	375	460	1125					
	7:1	336	420	1050					
	10:1	330	400	1050					
HPS180	4:1	1100	1200	3000	≤ 4	≤ 3	≥ 68	11000	11000
	5:1	1100	1200	3000					
	7:1	1050	1100	3000					
	10:1	690	900	3000					

Single stage units: Input Characteristics

Gearhead	Ratio	Gearhead Inertia Kgcm ²	Max Input speed rpm	Nominal Input speed rpm	Typical input Friction Nm	Efficiency	Max input shaft dia. mm	Gearhead Mass kg
HPS60	4:1	0.41	6000	3500	0.4	97%	14	1.5
	5:1	0.38		3500	0.37			
	7:1	0.37		4000	0.32			
	10:1	0.36		4000	0.28			
HPS75	4:1	0.84	6000	2500	0.6	97%	19	2.5
	5:1	0.77		2500	0.5			
	7:1	0.71		3000	0.4			
	10:1	0.69		3000	0.35			
HPS100	4:1	3.55	3000	2000	1.5	97%	24	6.5
	5:1	3.21		2000	1.2			
	7:1	2.94		2500	0.8			
	10:1	2.75		2500	0.6			
HPS140	4:1	8.51	3000	2000	3.4	97%	32	14.5
	5:1	7.31		2000	2.8			
	7:1	6.33		2500	2.0			
	10:1	5.71		2500	1.5			
HPS180	4:1	29.11	3000	1500	6	97%	38	29.5
	5:1	22.31		1500	5			
	7:1	17.52		2000	4			
	10:1	14.32		2000	3			

Double stage units: Output Characteristics

HPD series

Gearhead	Ratio	Continuous Torque Nm	Peak Torque Nm	Emergency Torque Nm	Standard Backlash arc min.	Reduced Backlash arc min.	Torsional Rigidity Nm/arc min.	Max Radial Load N	Max Axial Load N
HPD60	16:1	26	35	90	≤ 8	≤ 6	≥ 5	2000	2000
	20:1	28	35	90					
	28:1	25	35	90					
	40:1	26	35	90					
	50:1	28	38	90					
	70:1	23	31	90					
	100:1	18	34	85					
HPD75	16:1	63	75	190	≤ 8	≤ 6	≥ 8	2500	2500
	20:1	63	79	190					
	28:1	63	75	190					
	40:1	60	79	190					
	50:1	63	75	190					
	70:1	65	79	190					
	100:1	45	64	150					
HPD100	16:1	180	240	575	≤ 6	≤ 4	≥ 23	4000	4000
	20:1	180	248	575					
	28:1	180	240	575					
	40:1	180	248	575					
	50:1	180	240	575					
	70:1	178	220	575					
	100:1	144	204	500					
HPD140	16:1	375	460	1125	≤ 7	≤ 4	≥ 68	7500	7500
	20:1	375	432	1125					
	28:1	375	460	1125					
	40:1	348	432	1050					
	50:1	375	460	1125					
	70:1	336	420	1050					
	100:1	330	400	1050					
HPD180	16:1	1100	1200	2750	≤ 7	≤ 3	≥ 68	11000	11000
	20:1	1100	1200	2750					
	28:1	1100	1200	2750					
	40:1	1100	1200	2750					
	50:1	1100	1200	2750					
	70:1	1050	1100	2750					
	100:1	690	900	2250					

Selecting the correct output characteristic

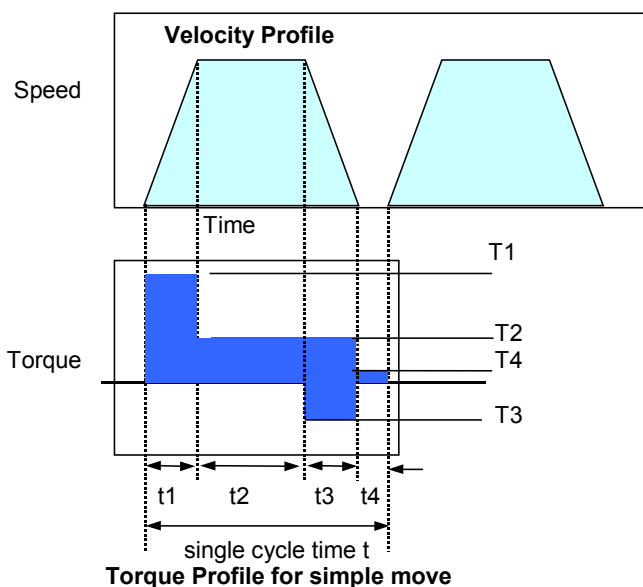

For repeated positioning applications
Calculate RMS Torque as follows:

$$TRMS = \sqrt{\frac{T1^2t1 + T2^2t2 + T3^2t3 + T4^2t4}{\text{Single cycle time } t}}$$

Select a Gearhead ratings so that:
Peak Torque ≥ Accel. & Decel. Torque
Continuous Torque ≥ TRMS x Fs

Service Factor Fs

Cycles per Hour	Fs
< 1000	1
1000-2000	1.2 – 1.5
2000-3000	1.5 – 2.0
> 3000	please consult us

Double stage units: Input Characteristics

Gearhead	Ratio	Gearhead Inertia Kgcm ²	Max Input speed rpm	Nominal Input speed rpm	Typical input Friction Nm	Efficiency	Max input shaft dia. mm	Gearhead Mass kg
HPD60	16:1	0.45	6000	4000	0.25	94%	14	1.7
	20:1	0.45		4000	0.20			
	28:1	0.45		4000	0.20			
	40:1	0.45		4000	0.20			
	50:1	0.45		4000	0.20			
	70:1	0.45		4000	0.20			
HPD75	16:1	0.76	6000	3000	0.35	94%	19	3.2
	20:1	0.76		3000	0.35			
	28:1	0.71		3000	0.35			
	40:1	0.70		3000	0.35			
	50:1	0.68		3000	0.35			
	70:1	0.68		3000	0.35			
HPD100	16:1	1.89	3000	2500	0.75	94%	24	8.0
	20:1	1.72		2500	0.62			
	28:1	1.71		2500	0.50			
	40:1	1.31		2500	0.40			
	50:1	1.31		2500	0.40			
	70:1	1.31		2500	0.40			
HPD140	16:1	7.71	3000	2500	1.4	94%	32	18
	20:1	7.23			1.2			
	28:1	7.11			1.0			
	40:1	5.7			1.0			
	50:1	5.7			0.8			
	70:1	5.3			0.8			
HPD180	16:1	11.31	3000	2500	3.8	94%	38	33
	20:1	10.7			3.0			
	28:1	10.4			2.5			
	40:1	8.71			1.5			
	50:1	8.65			1.5			
	70:1	8.65			1.2			
100:1	8.65	0.8						

Easyfit motor mounting

The motor is mounted via a precision flange that provides an accurate register for the motor.

The input pinion is mounted in it's own sealed bearings and incorporates a clamp that is tightened through the motor mounting adapter. The advantage of the design is easy mounting of the motor in both horizontal and vertical positions thereby providing improved serviceability.

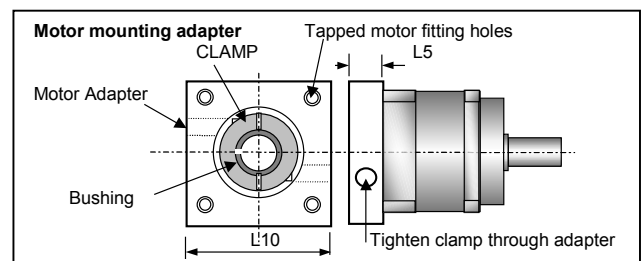

Selecting a suitable motor size

In a typical application requiring 1 positioning cycle every 2 seconds (1800 cycles per hour)

The following load characteristics are calculated:

Peak acceleration torque at the gearhead's output	= 150 Nm (required for 0.2 seconds)
Torque Trms	= 50 Nm
Peak output speed of 2 revs/sec	= 120 rpm
The load Inertia	= 3900 Kgcm ²
Using Service factor (Fs) of 1.5 select a gearhead where	
Peak Torque rating	= 1.5 x 150 ≥ 225 Nm
Nominal Torque rating	= 1.5 x 50 ≥ 75 Nm

Provisional Gearhead Selection: HPD100

Max Nominal input speed of gearhead	= 2500 rpm	
Ratio selected : 20:1 Input speed required	= 120 x 20	= 2400 rpm
Motor Peak torque to accelerate load	≥ $\frac{150}{20 \times 0.95}$	+ 0.62 = 8.52 Nm
Motor Rated torque to drive load	≥ $\frac{50}{20 \times 0.95}$	+ 0.62 = 3.25 Nm
Load Inertia related @ motor	= $\frac{3900}{20^2} + 1.72$	= 11.49 Kgcm ²

For an optimum combination of positioning performance and cost select a servo motor that has a rotor inertia of at least 1/5th the Load Inertia: ie: Minimum Motor Rotor Inertia ≥ 3.5 Kgcm²
 In addition ensure that the motor has sufficient torque reserve to accelerate the inertia of it's own rotor & that of the gearhead.

Typical Servo motor Peak torque requirement based on above load conditions;

If motor rotor inertia	= 3.4 Kgcm ²	
& Gearhead Inertia	= 1.72 Kgcm ²	
Acceleration Torque	$T_A = \frac{J \cdot \omega}{10t}$	where J = 3.4 + 1.72 = 5.12 Kgcm ²
		$\omega = \frac{2400 \times 2\pi}{60} = 251 \text{ rad/sec}$

To accelerate motor + gearhead TA =	$\frac{5.12 \times 251}{10 \times 200}$	Acceleration /deceleration time t = 0.2 secs = 200 milliseconds. = 0.64 Nm
Peak torque to accelerate load & overcome gearhead friction		= 8.52 Nm
Minimum Motor Peak torque required		= 9.16 Nm

Finally, ensure that a motor with the above characteristics has a shaft diameter ≤ 24 mm diameter

Gearhead selected: HPD100-20:1 ratio

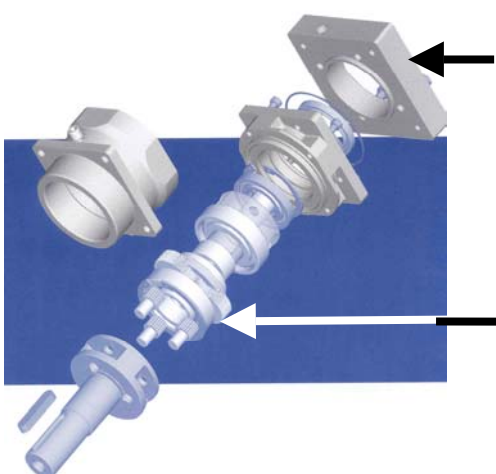

The HPD series B unit assembly incorporates a motor mounting adapter that is precision engineered to fit the motor selected.

The complete HP series gearhead is assembled using high grade components and utilises high grade synthetic oil to provide a service life of typically 20,000 hours at full rating, the input & output bearings being sealed for life.

For applications requiring extreme precision reduced backlash gear stages may be specified for a small increase in cost

Precision Planetary Gearheads

HP –B Series

Dimensions for units prepared for *easyfit* motor mounting

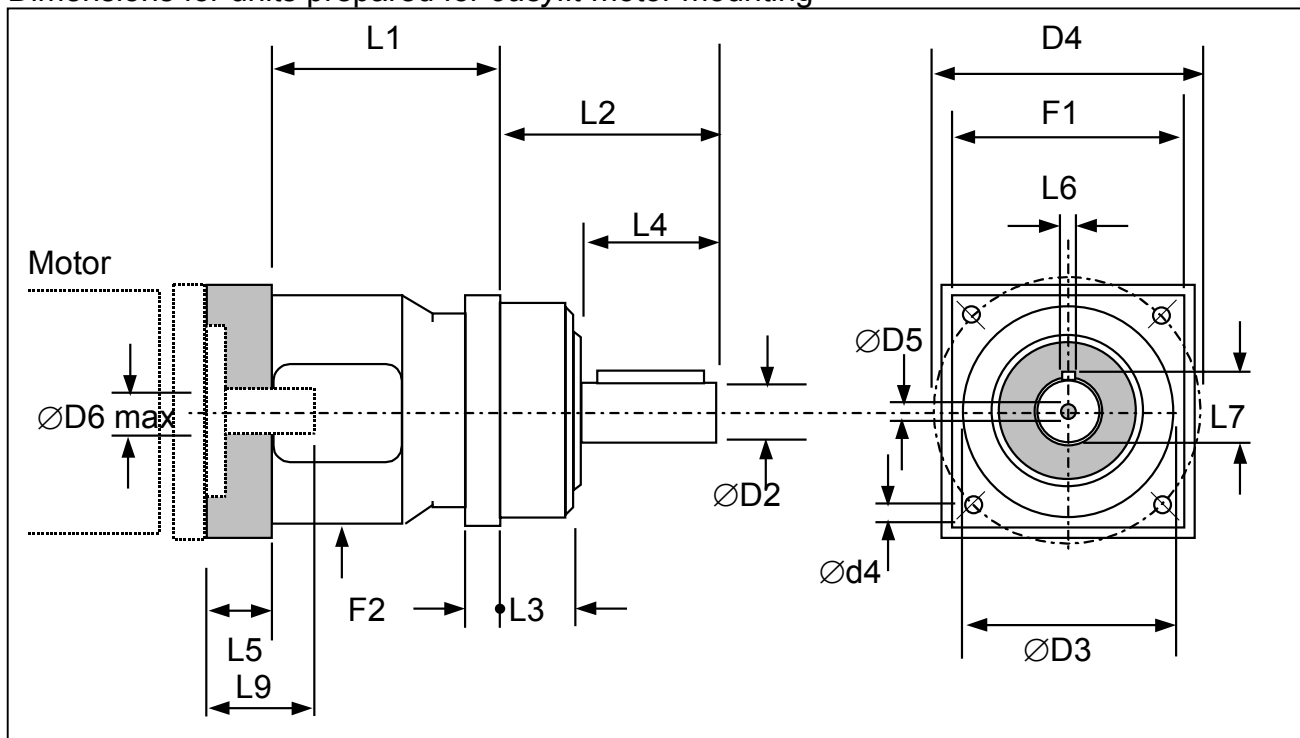
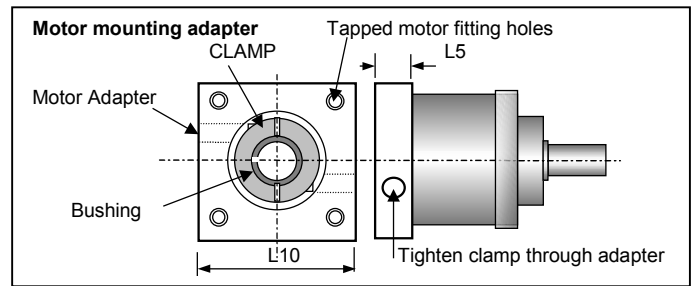

Table of dimensions: mm

Gearhead Series		HP60	HP75	HP100	HP140	HP180
Gearhead Flange square	F1	62	76	102	141	190
Output shaft diameter	D2	16 k6	22 k6	32 k6	40 k6	55 k6
Gearbox mounting register	D3	60 h6	70 h6	90 h6	130 h6	160 h6
Gearbox mounting holes	d4	6	7	9	11	13
mounting hole PCD	D4	68	85	120	165	215
Shaft fixing bolt size	D5	M5	M8	M12	M16	M20
Max motor shaft diameter	D6	14	19	24	32	38
Code for single / double stage		S D	S D	S D	S D	S D
Number of stages		1 2	1 2	1 2	1 2	1 2
Gearbox Body Length	L1	68 90	77 104	84 116	108 150	156 217
Flange thickness	F2	6	7	10	13	16
Overall Output Shaft length	L2	48	56	88	112	112
Gearbox register length	L3	18	18	28	27	27
Free shaft length	L4	26	34	56	79	79
Max Adaptor length *	L5	18	21	26	32	37
Output shaft key width	L6	5	6	10	12	16
Output shaft key height	L7	18	25	35	43	59
Max. motor shaft length *	L8	38	44	51	60	85
Note*		Adapter length varies with motor shaft length. Increased motor shaft lengths may be accommodated by increased adapter length				
Max Motor adaptor size	L10	70	100	110	150	192
Note*		Adapter size depends on flange of motor to be fitted to gearhead				

Motor fitting kit

The motor is fitted to the HP gearhead via a mounting kit that consists of a motor adapter that fits the motor flange and a bushing sleeve to fit the motor shaft.



Specifying the Mounting adapter kits

The following motor dimensions are used to select the appropriate motor mounting adapter kit. When specifying an adapter kit for a motor d complete the table below in order that an adapter kit can be engineered for the motor that is to be fitted to the gearhead:

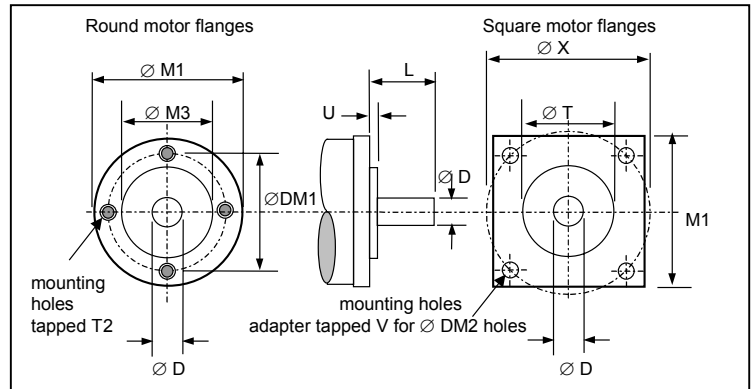

Two part adapters for motors with round mounting flanges

Fitting kit for motors with round flanges

When fitting a motor with a round flange a two part adapter is required as shown in the drawing.

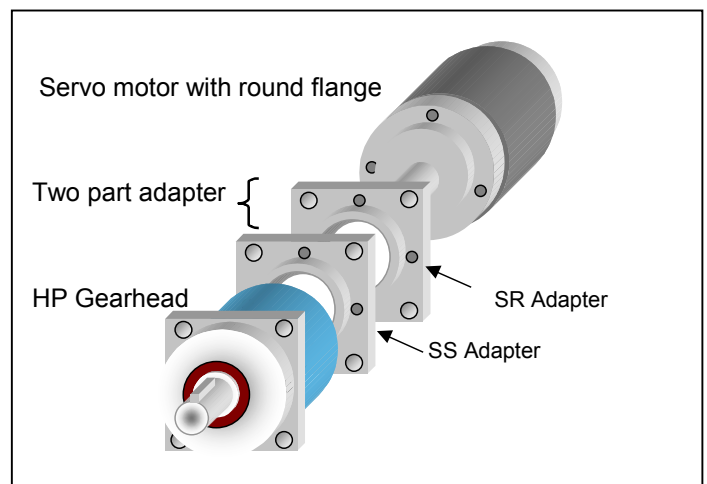

Adapter & motors & motors dimensions: mm

Adapters for motors			insert details for motors with square mounting flange						
Adapter Code	L10	L5	X	V Ø M2	T	U	D	L	
SS series									

Two part adapters for motors with round mounting flanges

Adapter details			Round Motor details						
Adapter Code	L10	L5	M1	M4	L9	M3	M6	tapped T2	DM1
SS series									
SR series									

Precision Planetary Gearheads

HP-C series

Option with input shaft

The HP-C series provide the same general performance options as the HP-B series but utilise an input / output shaft configuration. The following dimensions should therefore be read in conjunction with those for the HP-B series.

Input mounting dimensions & variations

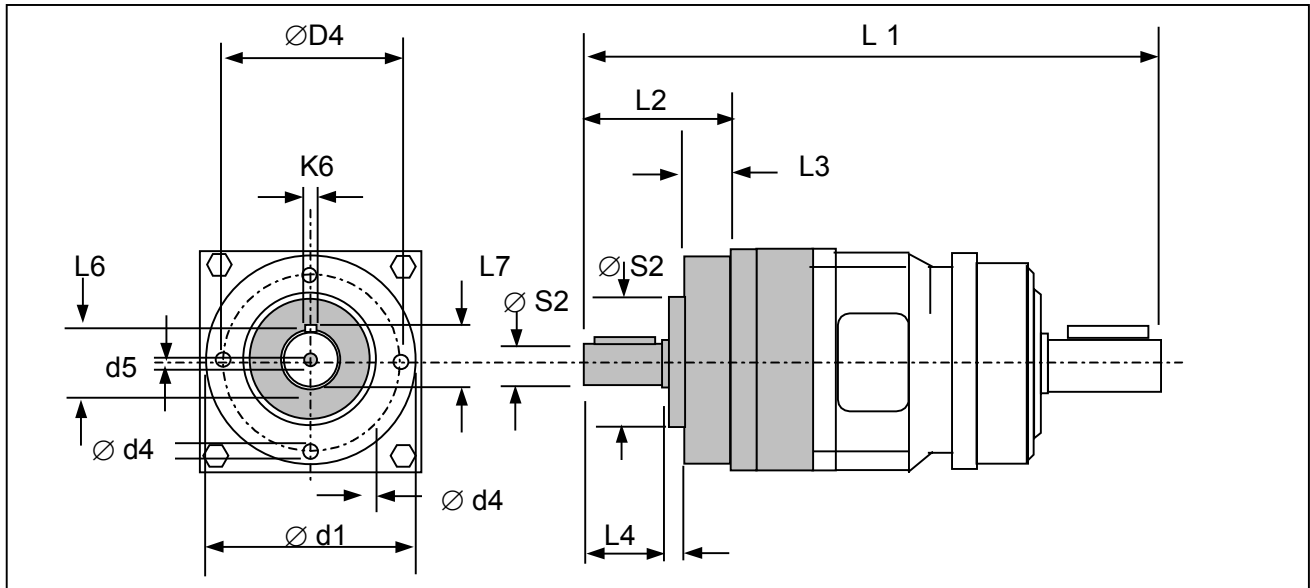
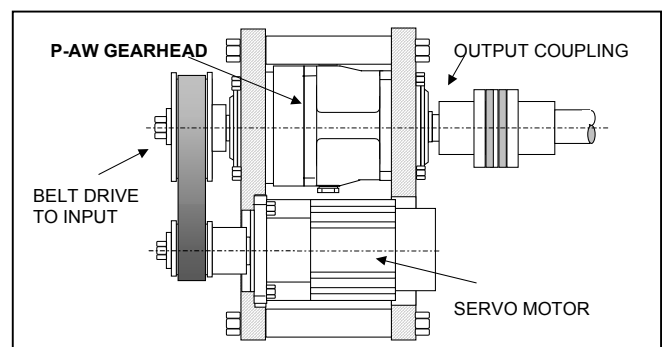

Table of dimensions: mm

Gearhead Series		HP60		HP75		HP100		HP140		HP180	
Code for single/double stage units		S	D	S	D	S	D	S	D	S	D
Number of stages		1	2	1	2	1	2	1	2	1	2
Input shaft diameter	S2 k6	12		16		22		32		32	
Input mounting register	d1 g6	60		75		100		140		180	
Input mounting holes	d4	M5		M6		M8		M10		M12	
mounting hole PCD	D4	52		66		80		105		150	
Shaft fixing bolt size	d5	M4		M5		M8		M12		M12	
Overall Length	L1	123	147	174	201	219	252	298	349	333	394
Overall INPUT Shaft length	L2	30		40		51		68		82	
Gearbox INPUT register length	L3	12		10		13		17		21	
Free shaft length	L4	17		28		36		58		58	
INPUT shaft key width	K6	4		5		6		10		10	
INPUT shaft key height	L6	14		18		26		35		35	

Typical Installation advantages

- Possibility to reduce overall installation length
- Possibility to increase overall reduction ratio by using belt reduction on input.
- Possibility to provide combined motorised and manual operation of mechanism



Precision Planetary Gearheads

HP series

Ordering codes:

The following ordering code is used to specify for the P series gearhead, a typical example being shown below:

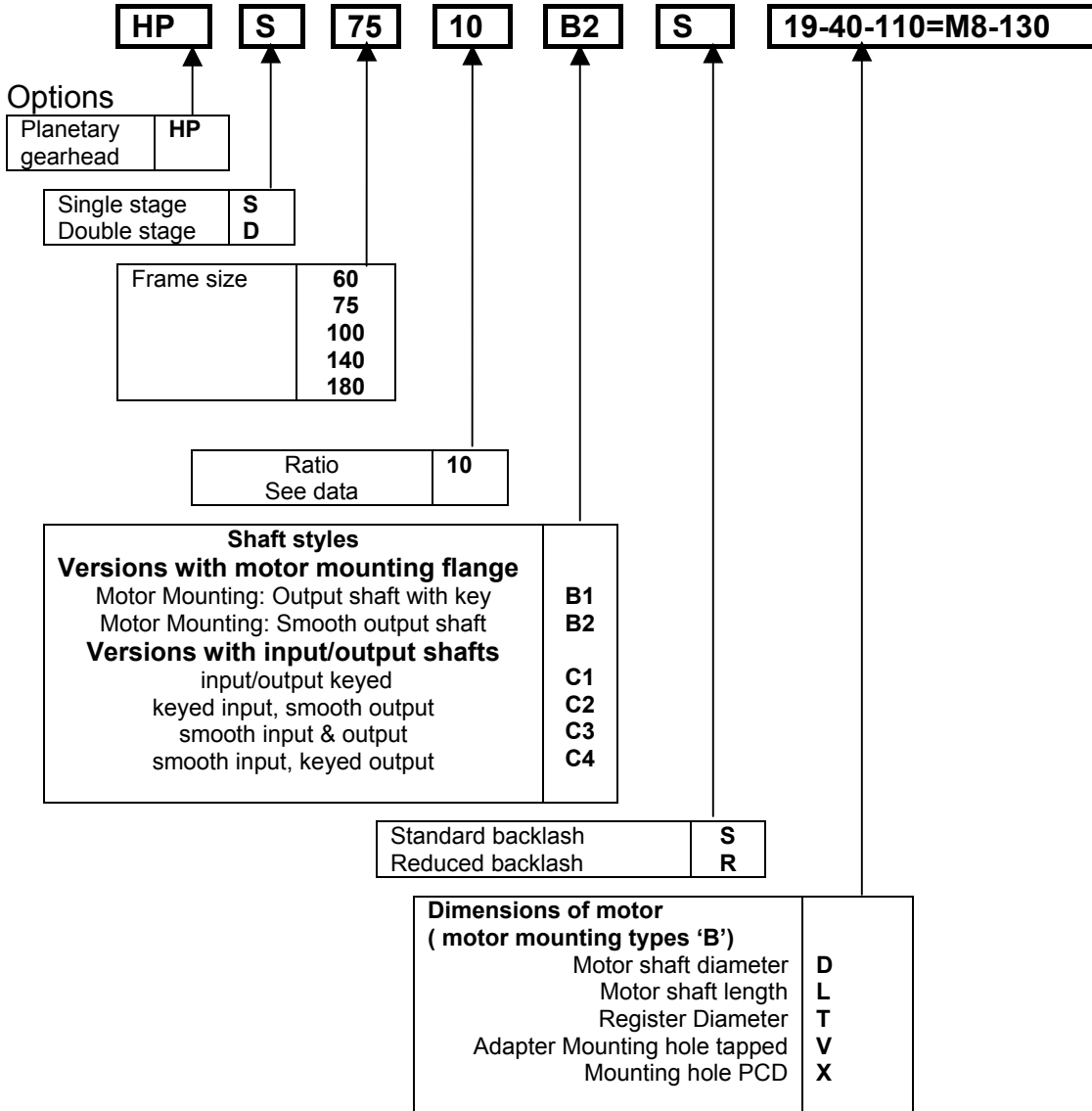

Mounting details

When ordering the gearhead the position in which it is mounted in the application should be specified as follows since this will determine the amount of lubricant used to provide optimum lubrication during the unit's life.

