

### IP57 series - Industrial Planetary Gearhead

The IP57 gear box is designed to provide long life in industrial automation, scientific and process control applications that require repetitive cycling featuring high dynamics and accurate velocity or positional control. Advanced manufacturing techniques have resulted in a combination of strong performance characteristics combined with economic prices.

- Planetary construction for high torque and compact dimensions.
- Suitable for use with both servo and stepper motors.
- Wide range of standard ratios with additional options also available.
- Integer gear ratios simplify calibration in positional control systems
- Standard options available from stock.



### IP57 series - Specifications

#### General specifications

Maximum shaft radial load	560N @ 5mm from gearhead mounting face for shaft options A & B 80N at 12mm from gearhead mounting face for shaft option C
Maximum shaft axial load	490N
Maximum Recommended Input speed	5000 rpm
Operating Temperature range	-40 to + 65 °C
Typical Input friction at motor	<0.05Nm

Part Number	No. Stages	Length (L)	Gear ratio	Maximum Continuous Torque	Maximum Peak Torque	Typical Backlash	Efficiency	Mass
		mm		Nm	Nm	Arc-min	%	g
IP57-M01	1	54	5:1	10	15	20	92	660
		54	10:1	9	13.5			
IP57-M02	2	66	25:1	20	30	30	84	880
		66	50:1	20	30			
		66	100:1	18	27			
IP57-M03	3	79	125:1	35	45	40	78	1110
		79	250:1	35	45			
		79	500:1	35	45			
		79	1000:1	31.5	45			



## IP57 - dimensions

### Outline dimensions

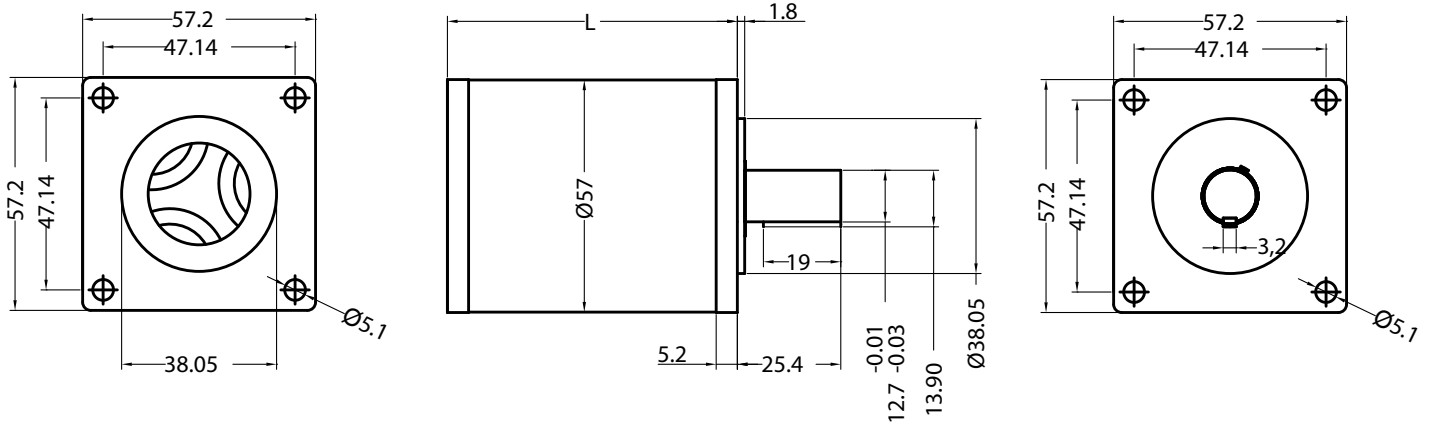

### Output shaft options

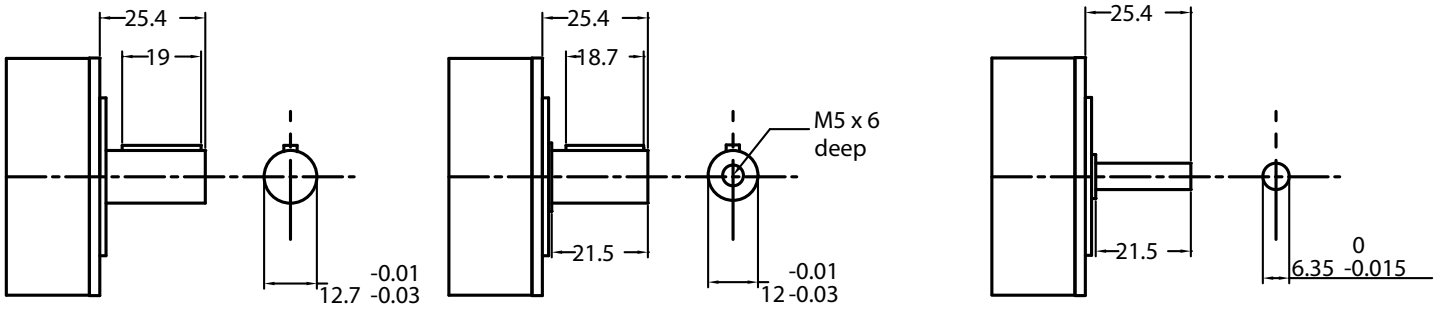

Option A: Standard shaft available from stock

Option B: Semi-standard shaft, special order only

Option C: Semi-standard shaft, special order only. Please note output torque is limited to 4Nm when using option C

## Common NEMA 23 motors fitted to an IP57

### 23HS and 23HSX series steppers

### V series servo motor

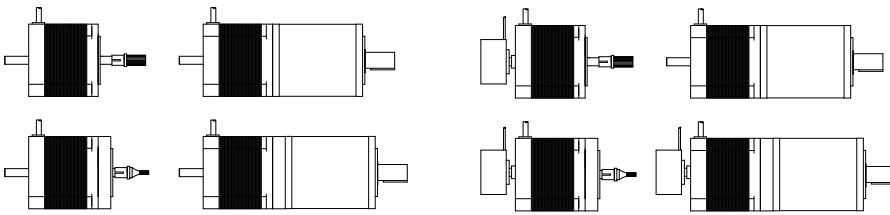

### Standard NEMA 23 motor fitting kits\*

	Motor Shaft Ø6.35mm	Motor Shaft Ø8.00mm
IP57-M01-5:1	400MAX00001	400MAX00017
IP57-M01-10:1	400MAX00002	400MAX00018
IP57-M02-25:1	400MAX00003	400MAX00019
IP57-M02-50:1	400MAX00004	400MAX00020
IP57-M02-100:1	400MAX00004	400MAX00020
IP57-M03-125:1	400MAX00003	400MAX00019
IP57-M03-250:1	400MAX00004	400MAX00020
IP57-M03-500:1	400MAX00004	400MAX00020
IP57-M03-1000:1	400MAX00004	400MAX00020

\*This is a guide only. Please consult Mclennan to confirm motor compatibility.

## Common round flange motors fitted to an IP57

BLDC58 series brushless motor

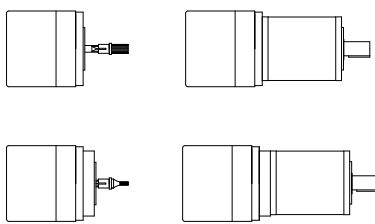

M500 series motor

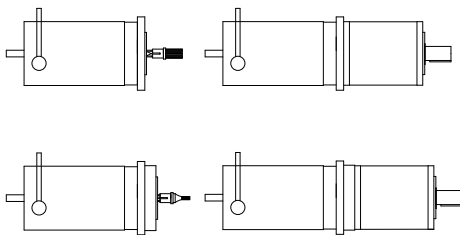

M66 series motor

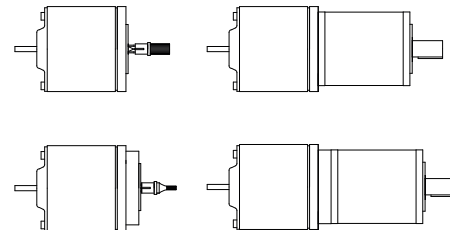

Standard round flange motor details and fitting kit\*

Shaft Diameter	Ø mm	6.00	6.00	8.00
Max. shaft length	mm	25	25	25
Bearing register	Ø mm	28	25	25
Max register length	mm	8.8	3	3
Mounting hole size		3 x M4	4 x M5 max	4 x M5 max
Mounting hole PCD	mm	50	38.89	38.89

Standard Gearheads

Fitting kit part no.

IP57-M01-5:1	400MAX00005	400MAX00009	400MAX00013
IP57-M01-10:1	400MAX00006	400MAX00010	400MAX00014
IP57-M02-25:1	400MAX00007	400MAX00011	400MAX00015
IP57-M02-50:1	400MAX00008	400MAX00012	400MAX00016
IP57-M02-100:1	400MAX00008	400MAX00012	400MAX00016
IP57-M03-125:1	400MAX00007	400MAX00015	400MAX00016
IP57-M03-250:1	400MAX00008	400MAX00012	400MAX00016
IP57-M03-500:1	400MAX00008	400MAX00012	400MAX00016
IP57-M03-1000:1	400MAX00008	400MAX00012	400MAX00016

\*This is a guide only. Please consult Mclennan to confirm motor compatibility.

Dimensions for pinion position

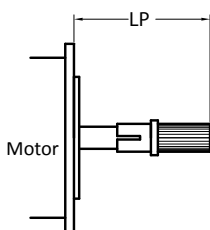

Optional pinion clamp

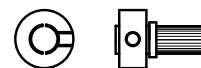

An optional pinion clamp may be ordered separately. This enables the pinion to be clamped in position.

Standard Gearhead Ratios	Motor Shaft Ø <6.35mm	Motor Shaft Ø <8.00mm
IP57-M01-5:1	28.25 /28.35 mm	41.95/42.05 mm
IP57-M01-10:1	41.95/42.05 mm	41.95/42.05 mm
IP57-M02-25:1	22.35/22.45 mm	36.05/36.15 mm
IP57-M02-50:1	36.05/36.15 mm	36.05/36.15 mm
IP57-M02-100:1	36.05/36.15 mm	36.05/36.15 mm
IP57-M03-125:1	22.35/22.45mm	36.05/36.15mm
IP57-M03-250:1	36.05/36.15 mm	36.05/36.15 mm
IP57-M03-500:1	36.05/36.15 mm	36.05/36.15 mm
IP57-M03-1000:1	36.05/36.15 mm	36.05/36.15 mm

Note\* Standard pinion fitted to shaft using Loctite 638.