

**NEW** - Extended Range  
with Stainless Steel Options

# HepcoMotion®

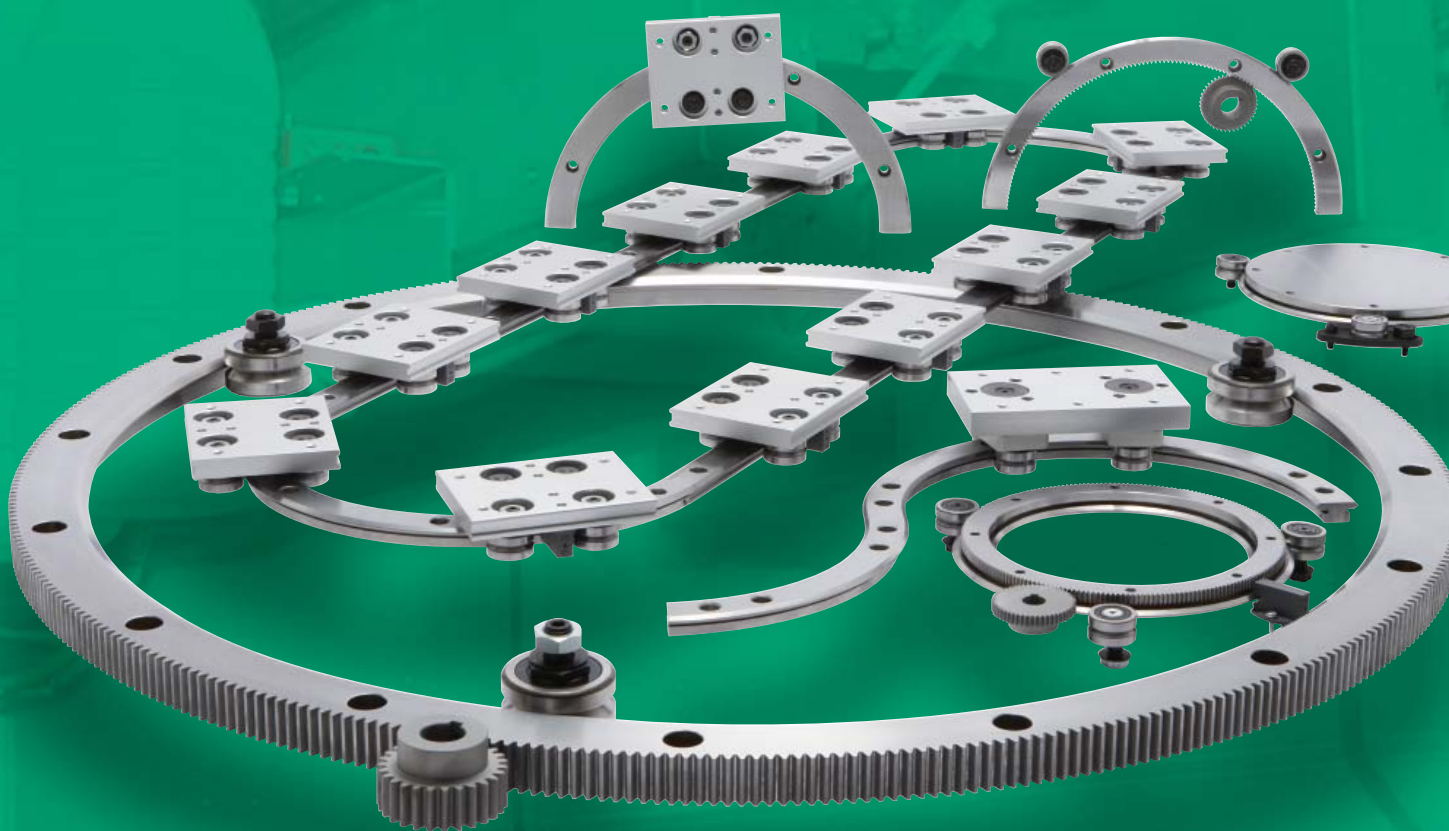

Precision Ring and  
Track System



## This catalogue interacts with the HepcoMotion website

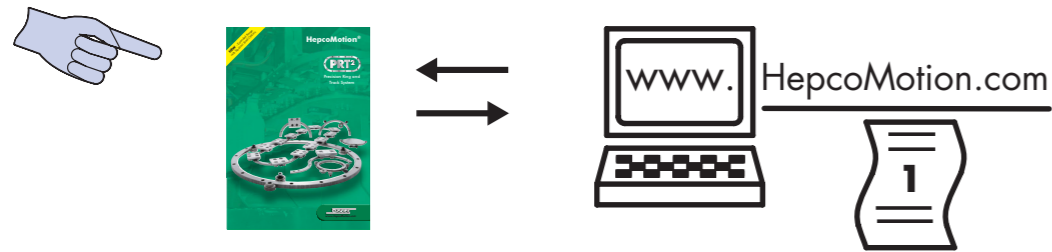

Additional information is available where you see this icon

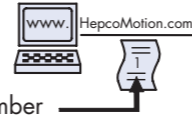

Data sheet number

From HepcoMotion home page



Literature



PRT2

On this web page are the datasheets referred to in this catalogue, plus information on new additions to the PRT2 range and downloads for the catalogue and catalogue amendments.

## Introducing the HepcoMotion® PRT2 Precision Ring and Track System

HepcoMotion has been solving Customers' circular motion problems for many years, building an indispensable knowledge of applications and clever technical solutions. This knowledge coupled with extensive research and development has resulted in the introduction of a comprehensive range of precision ring slides and track systems to suit virtually every need. Based on the highly successful PRT product the new PRT2 system offers a greatly expanded range of sizes and options including stainless steel availability as standard. The Precision Ring Slide and Track System products compliment Hepco's highly successful and extensive range of linear motion products, enabling customers to choose a single source for all their motion guidance requirements.

### Features & Benefits

#### Common

- Friction-free motion.
- Stainless steel options.
- Fully adjustable.
- Tolerant of debris.
- Simple and effective means of lubrication.
- Zero play.
- Works in any plane.
- Tolerant of misalignment.
- Easy to install.
- 2D & 3D CAD files available.

#### Ring Slides and Segments





- Circular motion control at the periphery where it is needed.
- Large hollow centre to accommodate other components (ring slides).
- Precision flat surface for mounting ancillary components (ring discs).
- Will track the curvature of cylindrical shapes.
- Gearcut options for ease of driving.
- Double edge and single edge versions available.
- Carriage brake available.

#### Track Systems

- Limitless variety of circuits available.
- Precision positioning system available.
- High load support option at work stations.
- Simple alignment facility provided.
- Various carriage plate options.
- Components available for driving.
- Support frame available.

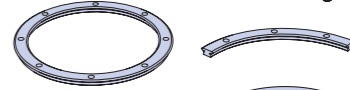
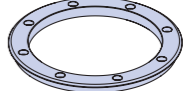
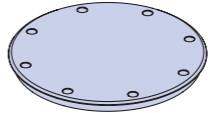
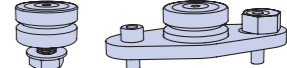
For amendments and updates visit [www.HepcoMotion.com](http://www.HepcoMotion.com) and select literature button

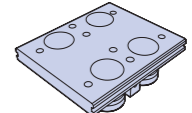
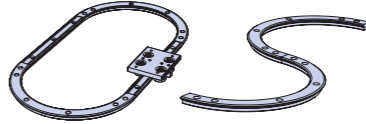
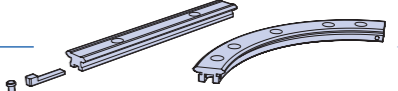
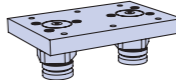
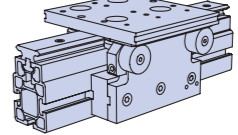
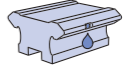
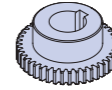
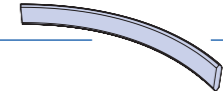
### Contents

<b>System Composition</b>	_____	<b>2-7</b>
<b>Application Examples</b>	_____	<b>8-19</b>
<b>Full Size Illustrations for Initial Selection</b>	_____	<b>20-21</b>
<b>Assembled Ring System</b>	 _____	<b>22-25</b>
<b>Double Edge Ring Slides and Segments</b>	 _____	<b>26-27</b>
<b>Single Edge Ring Slides and Segments</b>	 _____	<b>28-31</b>
<b>Rings Discs</b>	 _____	<b>32-33</b>
<b>Bearings</b>	 _____	<b>34-36</b>
<b>Lubricators</b>	 _____	<b>37</b>
<b>Fixed Centre Carriages</b>	 _____	<b>38-39</b>
<b>Track Systems</b>	 _____	<b>40-41</b>
<b>Track System Straight Slides and Curved Segments</b>	 _____	<b>42-46</b>
<b>Bogie Carriages</b>	 _____	<b>47</b>
<b>Moment Load Carriages</b>	 _____	<b>48-49</b>
<b>Driven Track System Components</b>	_____	<b>50-51</b>
<b>Bleed Lubrication</b>	 _____	<b>52</b>
<b>Pinions</b>	 _____	<b>53</b>
<b>Technical Section</b>	_____	<b>54-58</b>
<b>Technical Specifications</b>	_____	<b>59</b>
<b>Rolled Rings, Segments &amp; Specials</b>	 _____	<b>60</b>
<b>Related Products</b>	 _____	<b>61</b>

## System Composition

The HepcoMotion PRT2 system comprises of a comprehensive range of ring slides, ring segments, bearings and ancillary components which provide a versatile solution for most rotary and track system applications. A large range of ring slide types in various diameters are available in both steel and stainless steel with hardened V edges. Stock 90° and 180° segments are also available. Gear cut versions are available with pinions to provide a simple and effective means of driving. An overview of the comprehensive product range is shown  2 - 7.

### Double Edge V Ring Slide 26-27

- Bearings can be mounted internally and externally.
- Carriages can be run on double edge rings.
- Precision ground all over for high accuracy and conformity.
- Large hollow centre to accommodate other components.
- Datum register faces provided internally and externally for ease of location.
- Internal/External gear cut options available for ease of driving.
- V edges hardened for maximum wear resistance.
- Soft centre section allows customising.
- Stainless steel option available as standard.
- Through hole fixing or tapped hole fixing.
- Comprehensive range of drive pinions available  53.

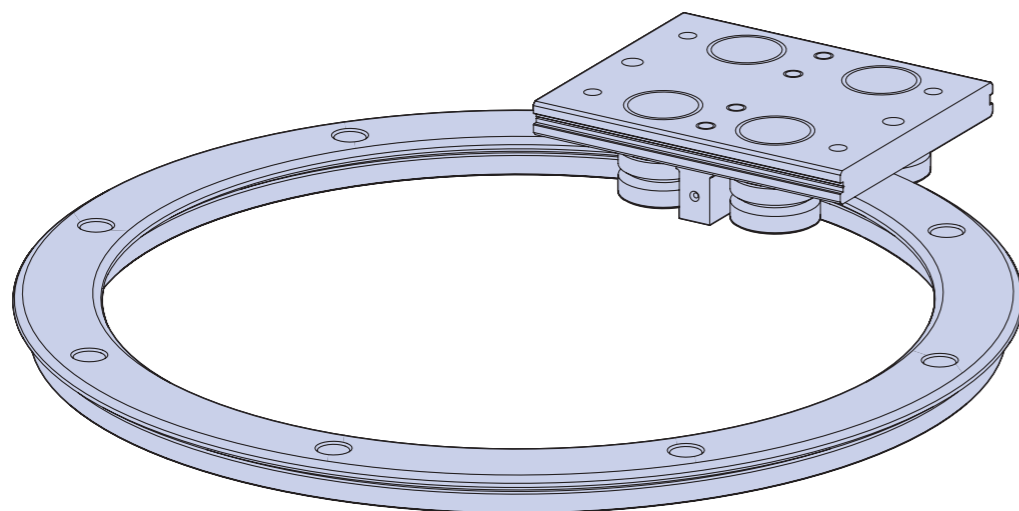

### V Ring Segments 26-31

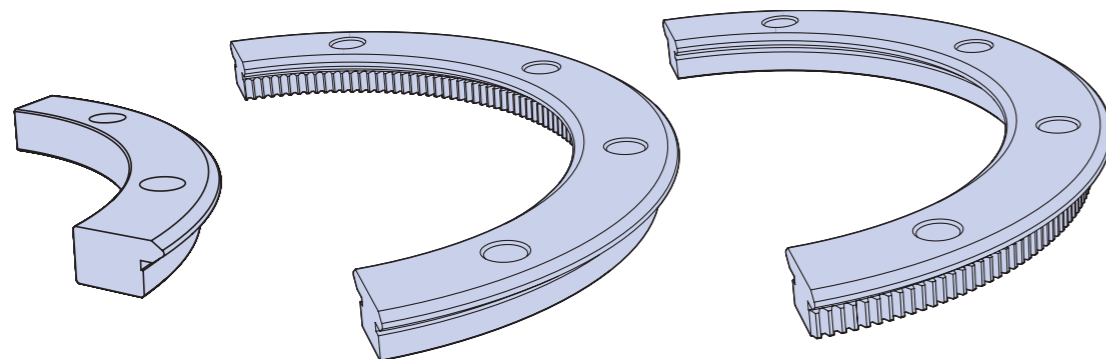

- 90° and 180° segments available as standard.
- Double edge V and single edge V ring segments available as standard.
- Special length segments available to order.

## System Composition

### Single Edge External V Ring Slide 28-29

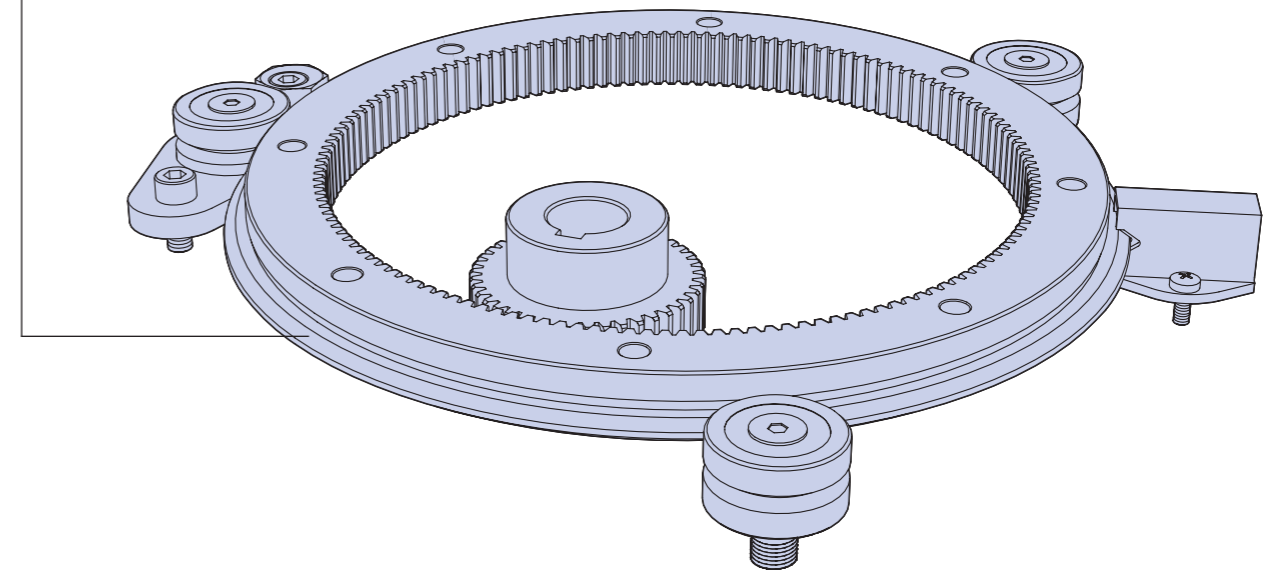

#### Common features

- Narrow section width.
- Datum register face for ease of location.
- Large gear size and face width.
- Stainless steel option available as standard.
- V face hardened for maximum wear resistance.
- Soft centre section allows customising.
- Manufactured from high quality steel.
- Choice of external or internal V.
- Precision ground all over for high accuracy and conformity.
- Through hole fixing or tapped hole fixing.
- Can be used in any orientation.
- Comprehensive range of sizes.
- Comprehensive range of drive pinions available  53.

### Single Edge Internal V Ring Slide 30-31

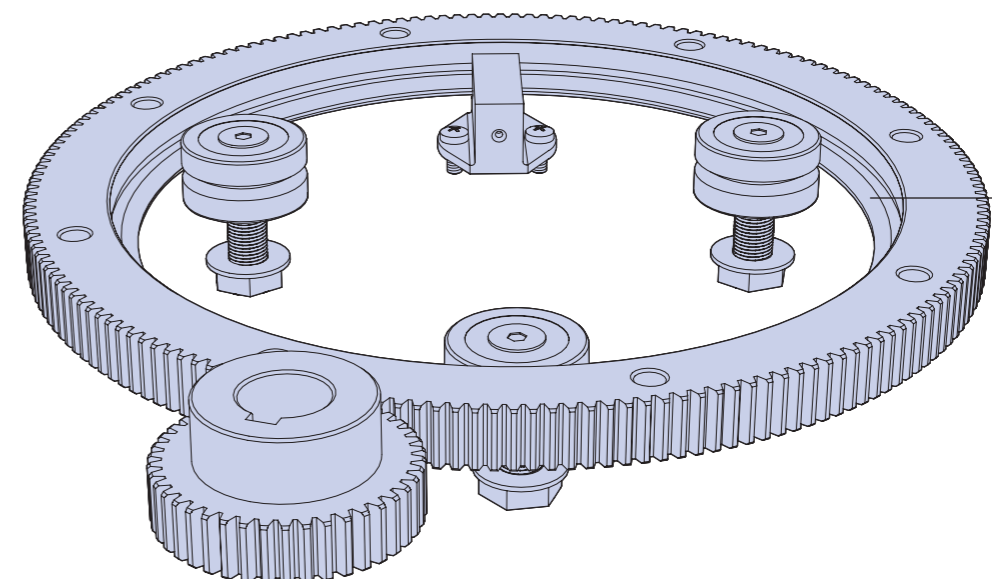

## System Composition

HepcoMotion bearings are available in a range of 5 useful sizes and various formats to suit most design requirements. The special raceway conformity and low radial clearance make these bearings particularly suited to ring slide applications. All bearings are lubricated for life internally and are available with metal shields for exclusion of particulates and low friction running or, with nitrile seals to inhibit ingress of liquids. Bearings are also available in stainless steel fitted with nitrile seals.

### ● Through hole fixing bearing (concentric) 34-35

### \* Through Hole fixing bearing (eccentric) 34-35

- Provides datum reference for the system.
- \* Short fixing stud for thin carriage plate.
- \* Long fixing stud for thick carriage plate.
- \* Controlled height option for enhanced system height accuracy.
- \* Provides simple means of adjusting via centre hexagon or socket in stud.
- \* Eccentric adjustment sufficient to allow removal of the ring or carriage without disassembly.

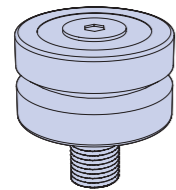
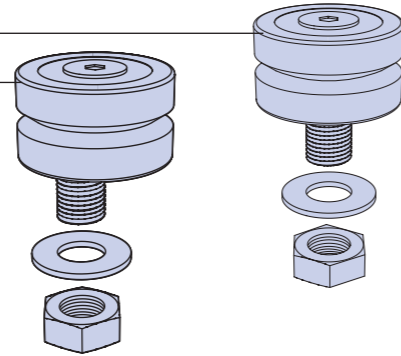

### ● Blind hole fixing bearing (concentric) 34-35

- For mounting into thick plates or where access to opposite side is restricted.
- Provides datum reference for the system.
- Controlled height option for enhanced system height accuracy.

### ● Blind hole fixing bearing (eccentric) 34-35

- For mounting into thick plates or where access to opposite side is restricted.
- Adjustable from operating side for ease of access.
- Controlled height option for enhanced system height accuracy.
- Easily removed to allow removal of ring.

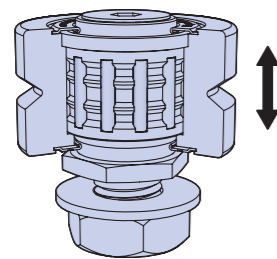
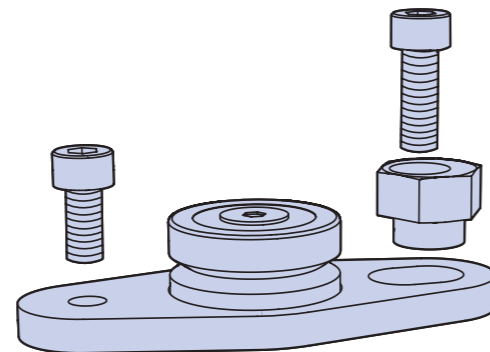

### ● Floating bearing (concentric & eccentric) 36

- Axial float of outer race accommodates variation in system height.
- Provides simple means of adjusting via centre hexagon or socket in stud.
- Short fixing stud for thin carriage plate.
- Long fixing stud for thick carriage plate.
- Double eccentric version has sufficient adjustment to allow removal of the ring or carriage without disassembly.

### \* Double Row Bearing / Twin Bearing 34-35 ●

- Twin bearing for tolerance of misalignment and smooth running.
- Double row bearing for tolerance of debris and higher load capacity.
- \* Special raceway conformity and low radial clearance, for slide ring applications.
- \* General quality to ISO Class 4. Aspects to Class 2.

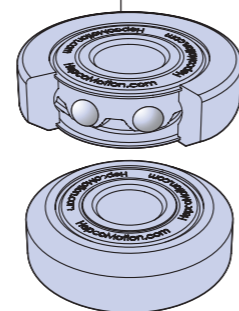
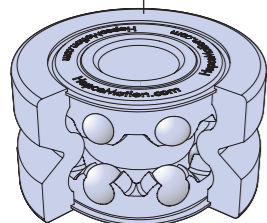

## System Composition

HepcoMotion track systems combine ring segments with straight slides to achieve an almost limitless variation of open paths or closed circuits. Both left and right hand bends can be negotiated depending on the carriage selected. 90° and 180° segments in all standard double edge ring sizes are available in addition to straight slides up to 4 metres long. Straight slides can be butted together to achieve track systems of unlimited length.

### Driven track system components 50-51

- Comprehensive range of drive components available from complete proven system.
- Trip latch overload protection.
- Carriage positioning and locking system.
- Toothed belt with carriage connection facility.
- Corner support plates.
- Drive and idler pulleys with Hi-load bearing cartridges.
- Support frame with slide attachment facility.

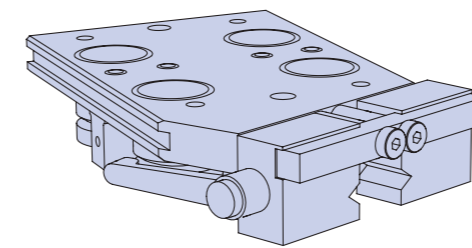
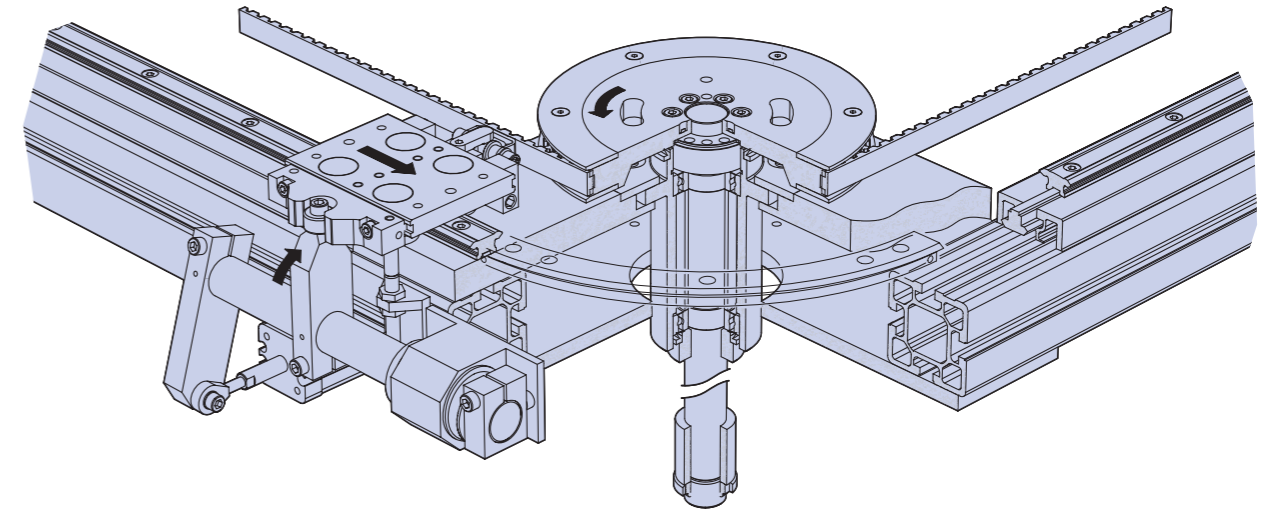

### ● Fixed centre carriage 38-39

- The economic choice for rings and uni-directional track systems.
- Optional lubricators for increased load & life.
- Keyway facility in side faces for location of ancillary components.
- Supplied with tapped holes for ease of component mounting.
- Accurate overall height.
- Corrosion resistant version available.
- Clamping brake version for ring systems. See illustration left.
- Compatible with track system drive components and carriage locking system.

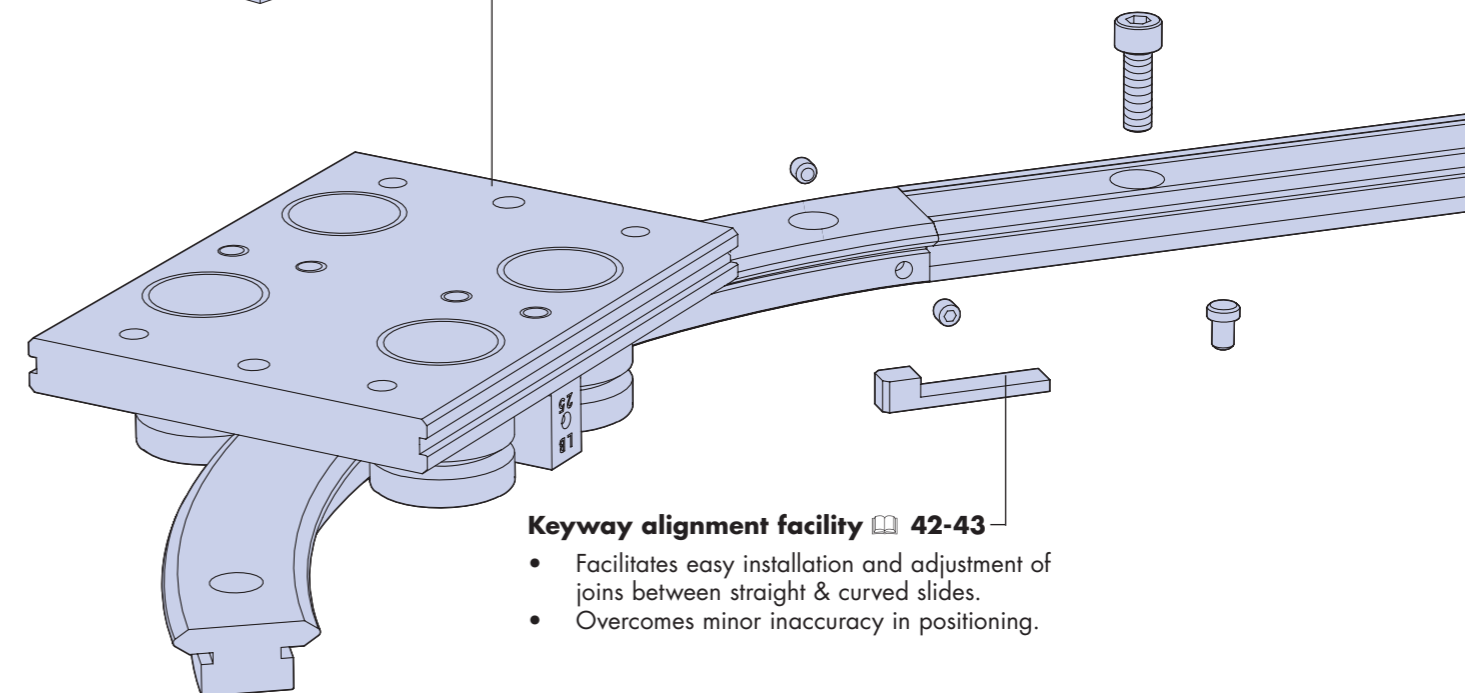

### ● Keyway alignment facility 42-43

- Facilitates easy installation and adjustment of joints between straight & curved slides.
- Overcomes minor inaccuracy in positioning.

## System Composition

### • Track system straight slides 42-43 / Track system curved segments 44 \*

- \* Hardened V faces for maximum wear resistance.
- \* Soft centre allows customising.
- \* Precision ground on ends and all important faces.
- \* Stainless steel option.
- \* All segments and slides precision matched.
- \* Ground datum faces for location purposes.
- \* Option available to suit pre-drilled mounting holes.
- \* 90° and 180° segments available from stock.
- \* Any length segment available to order.
- Central keyway for location and alignment.
- Up to 4m in one piece, unlimited length achieved by butting.

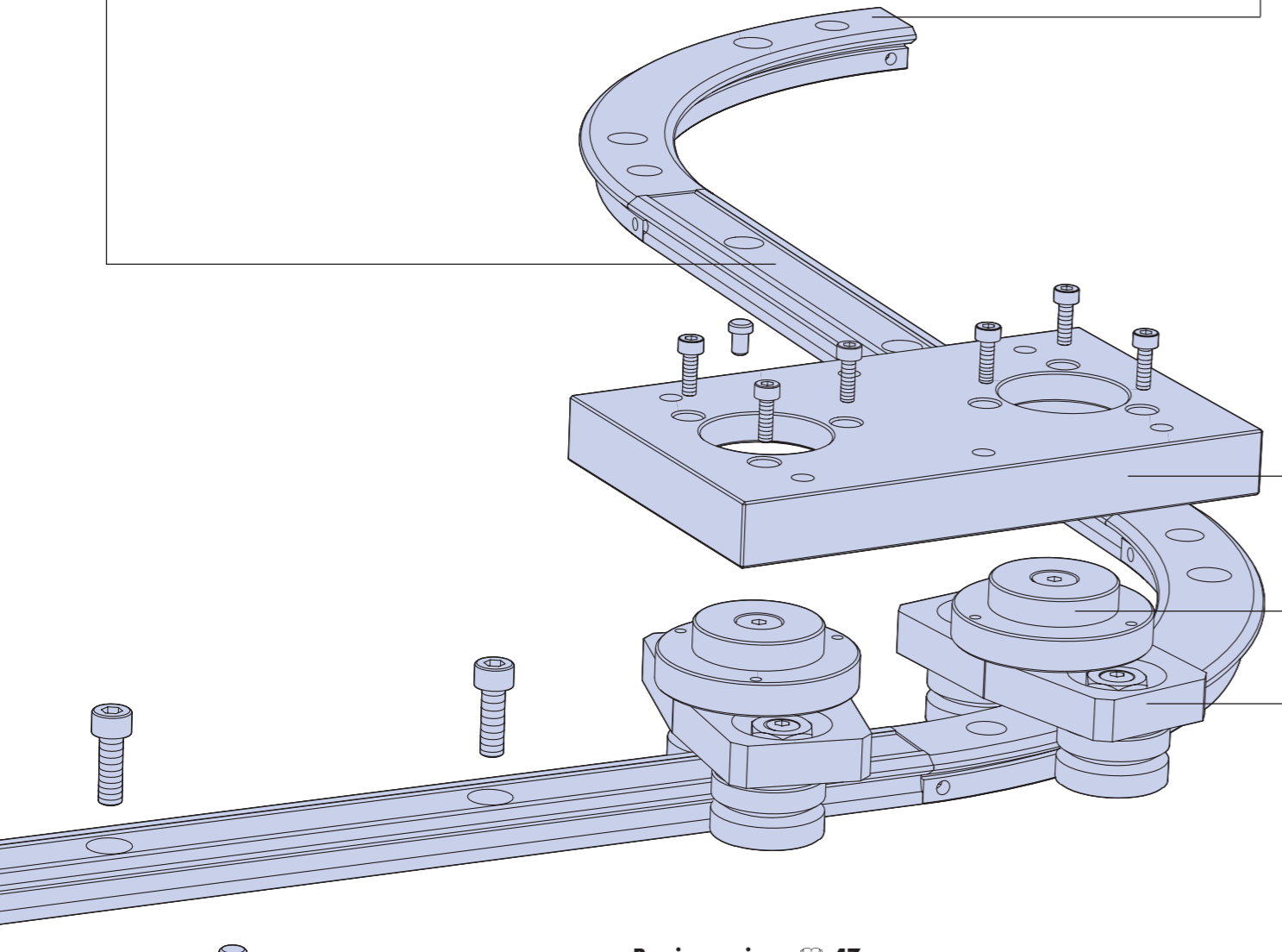

### Dowel pins 42-43

- Locates in central keyway of straight slide for ease of location and alignment.

### Bogie carriage 47

- Negotiates 'S' bends and differing bend radii.
- High performance swivel bearing for precision movement and extreme rigidity.
- Swivel bearings are lubricated for life internally.
- Available in three sizes to suit 25, 44 & 76 track systems.
- Supplied with tapped holes for ease of component mounting.
- Accurate overall height.
- Large platform for mounting purposes.

## System Composition

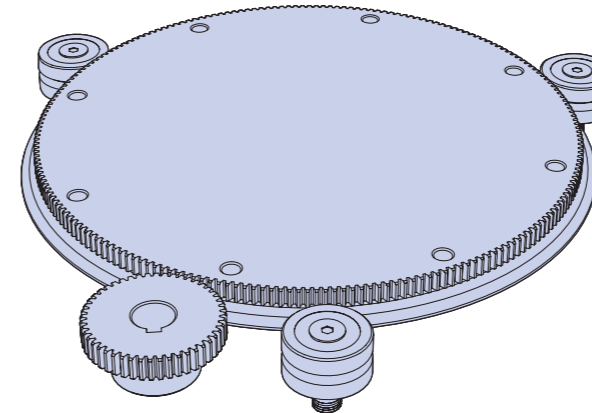

### Ring Disc 32-33

- Ideally suited to turntable applications.
- Large precision mounting surface easily customised to suit customer's components.
- Precision ground all over for high accuracy and conformity.
- Gear cut option for ease of driving.
- Useful range of sizes available.
- Choice of fixing, counterbored holes or tapped hole option.
- V edge hardened for maximum wear resistance.
- Stainless steel option available.

### Moment load carriage 48-49

- Supports overhanging loads and increases direct load capacity at workstations.
- Compatible with HepcoMotion carriage locking system and support frame.
- Compatible with HepcoMotion belt drive connection facility.
- Many support options possible using standard components.
- Static and dynamic support possibilities.

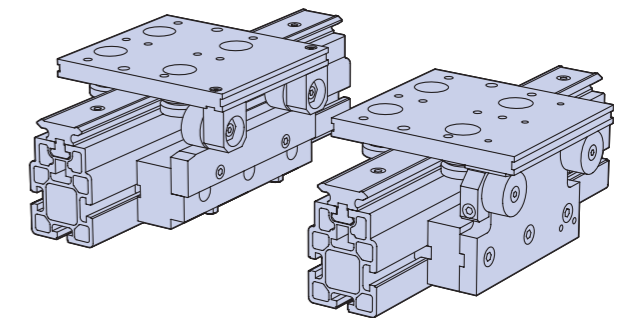

### Lubricators 37

- Provides lubrication to the contact faces thereby increasing load capacity and life.
- Long lubrication interval.
- Lightly sprung felt wiper for low friction.
- Compact type suitable for through hole fixing, flanged type for through and blind hole fixing.

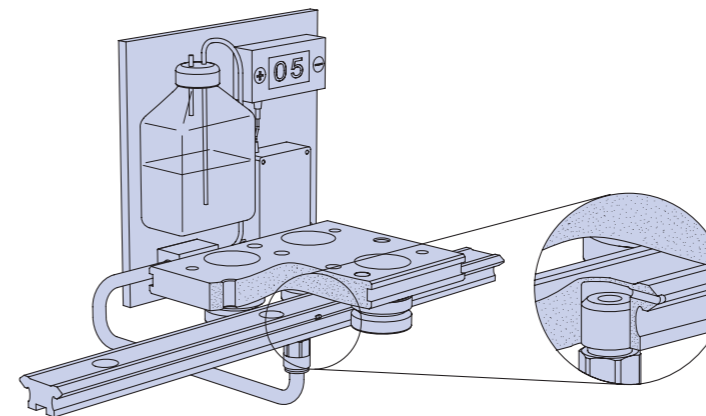
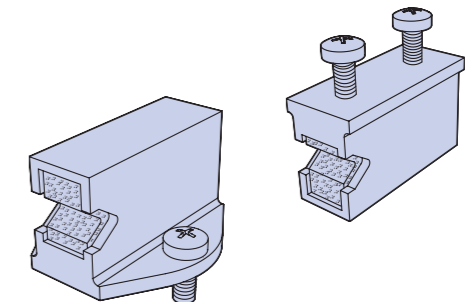

### Bleed lubrication 52

- Suitable for use with track systems.
- Lubrication piped through holes, direct into the V contact faces.
- Controlled metering of lubrication.
- Overcomes necessity for lubrication service intervals

### Pinions 53

- Sizes to suit all gear cut ring slides, segments and ring discs.
- Ground teeth for long life and smooth operation on sizes 1 module and above.
- Hardened teeth on larger sizes for increased durability.
- All pinions available in stainless steel as option.
- Precision machined bore, and optional keyway on sizes 1 module and above.

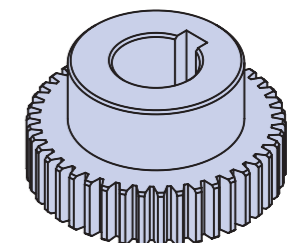

## Application Examples

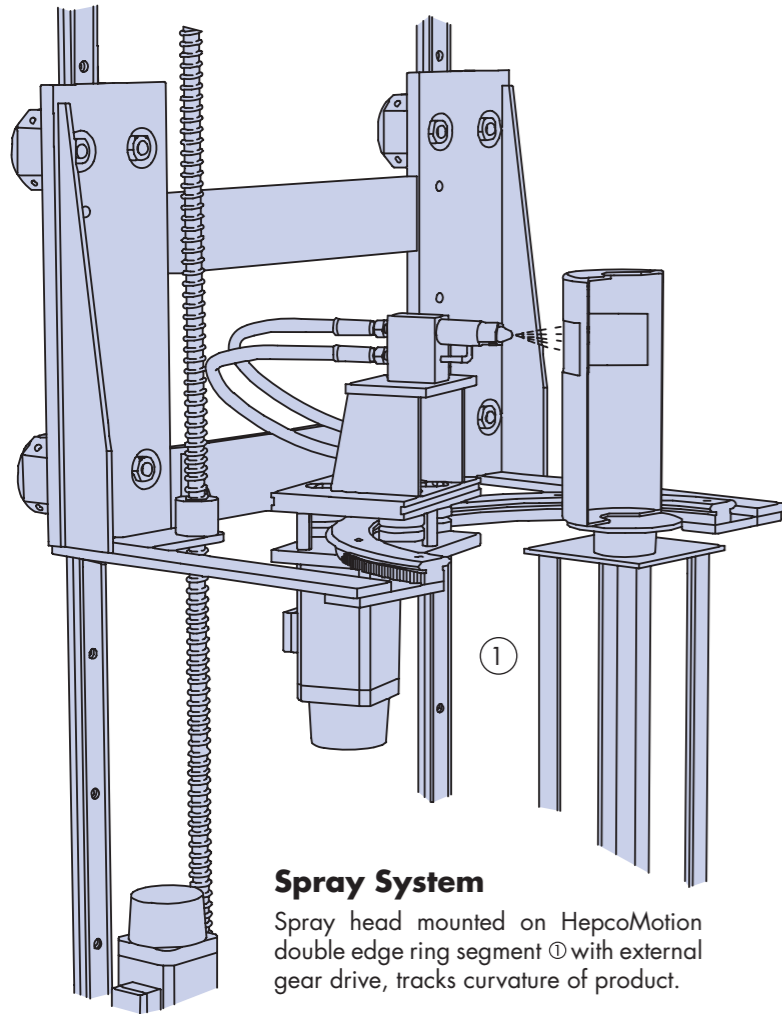

### Spray System

Spray head mounted on HepcoMotion double edge ring segment ① with external gear drive, tracks curvature of product.

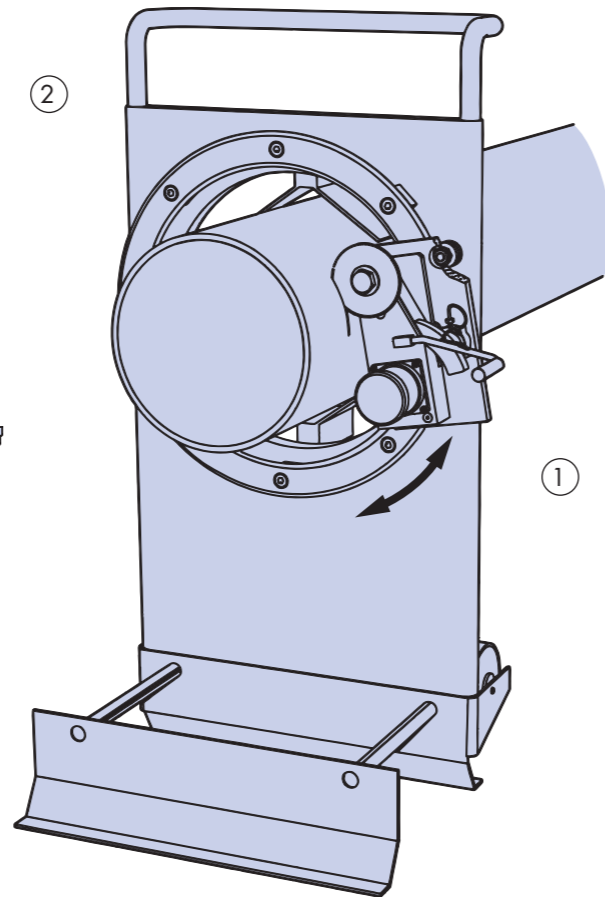

### Mobile Saw for Long Tubes

Motor and saw assembly mounted on carriage ① is hand operated around 360° HepcoMotion double edge ring slide ② in order to cut tube.

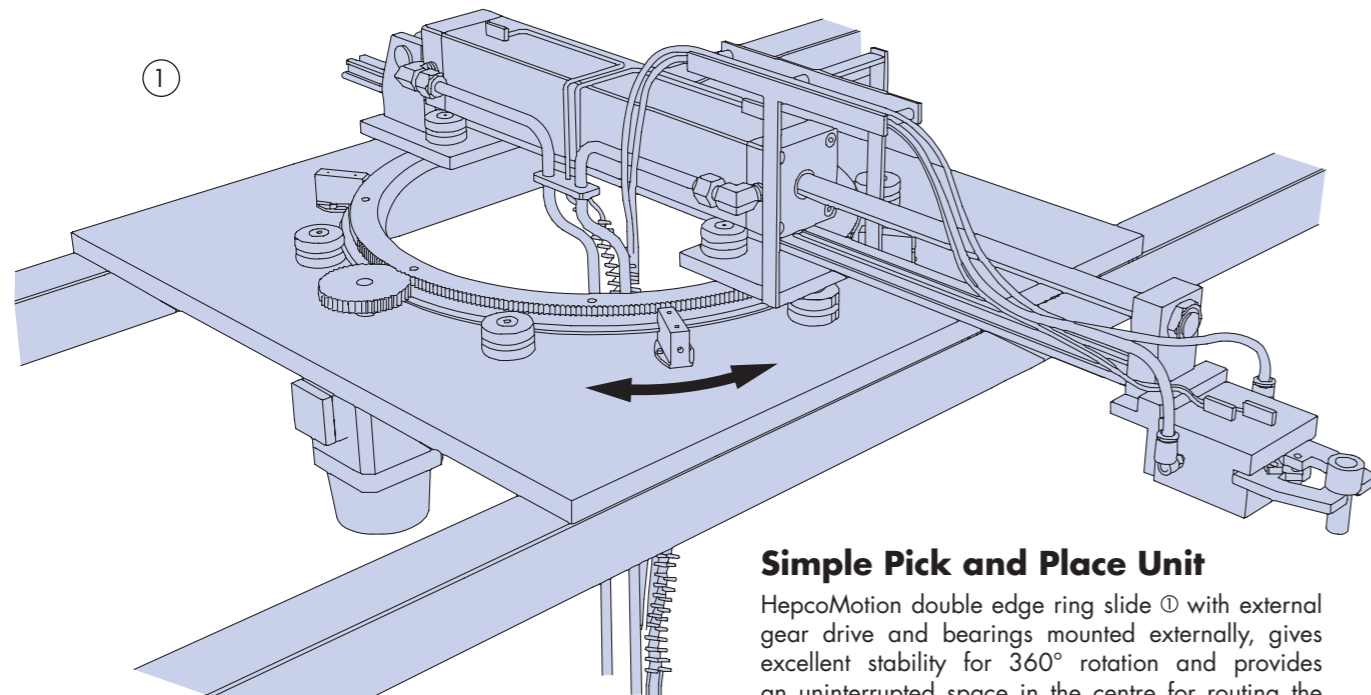

### Simple Pick and Place Unit

HepcoMotion double edge ring slide ① with external gear drive and bearings mounted externally, gives excellent stability for 360° rotation and provides an uninterrupted space in the centre for routing the services.

## Application Examples

### Three Axis Assembly Robot

HepcoMotion ring disc with gear drive ① provides an ideal platform on which to mount the robot. The large diameter disc with HepcoMotion bearings gives support at the periphery, ensuring excellent stability and friction free motion.

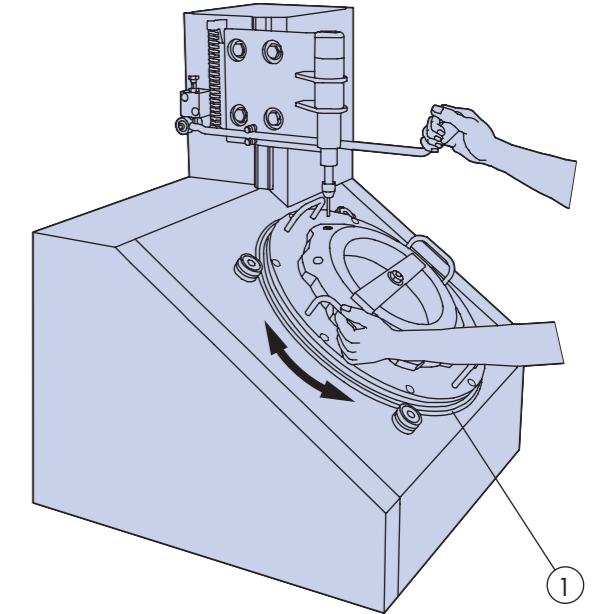
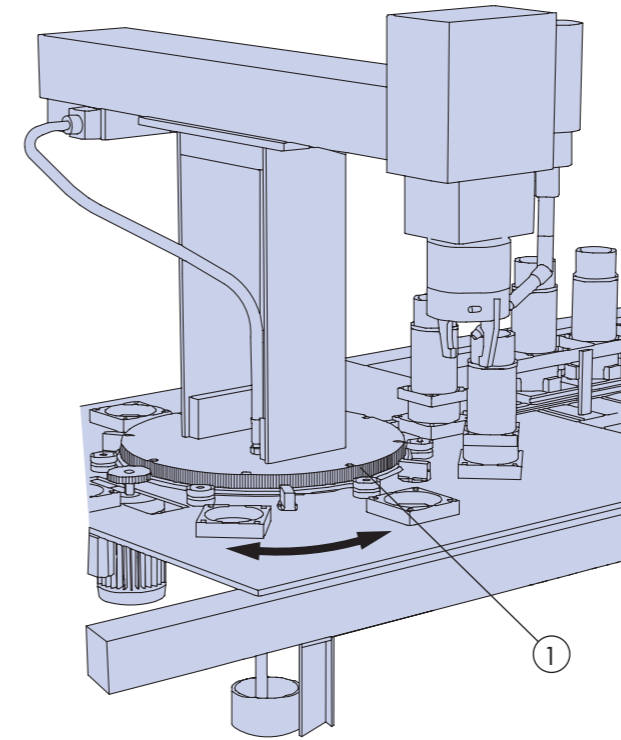

### Rotary Assembly fixture

HepcoMotion ring disc ① provides a large mounting area for attaching components. The precision ground surface ensures accuracy and the unhardened area inboard of the V's enables tooling holes to be drilled as required.

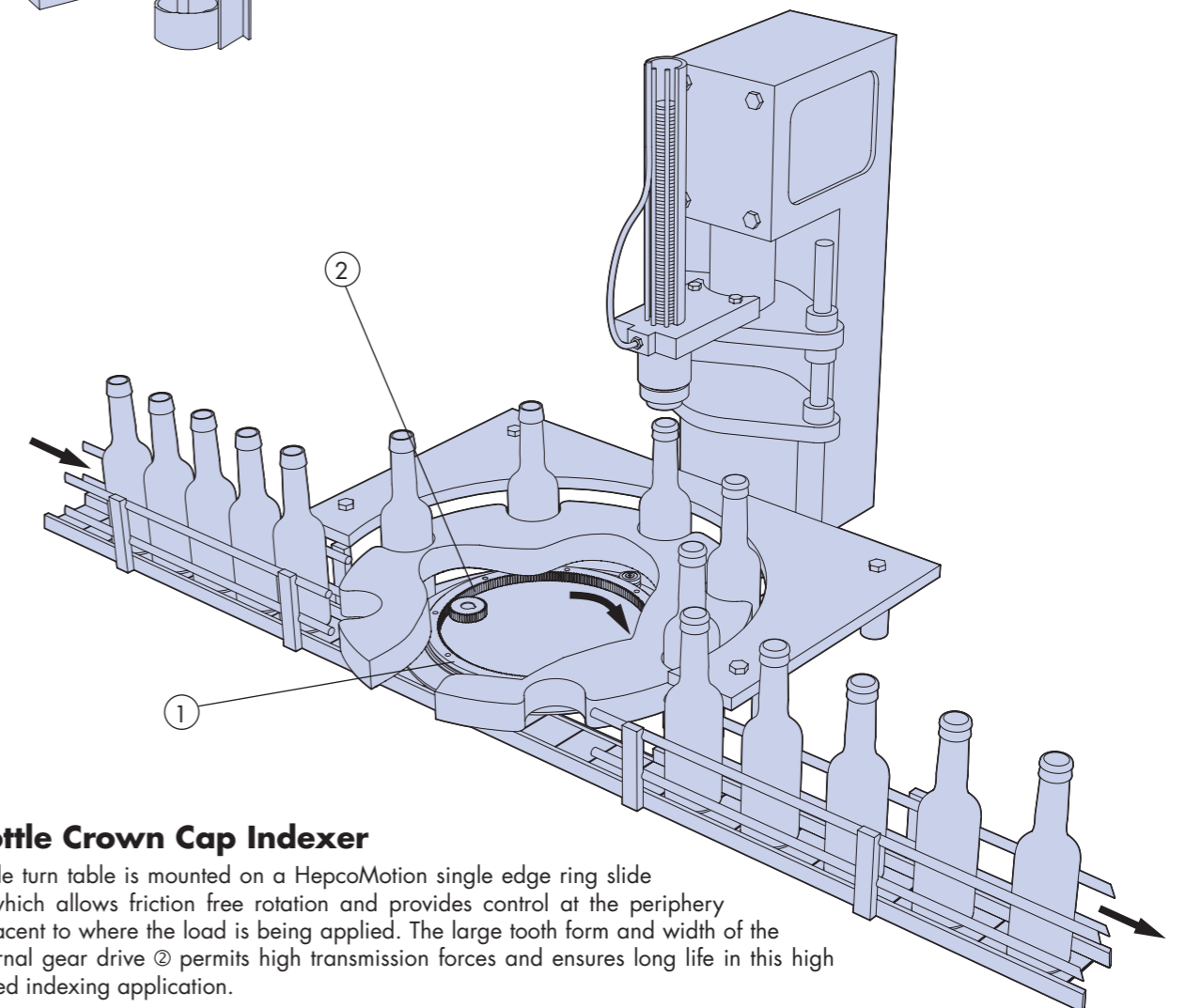

### Bottle Crown Cap Indexer

Bottle turn table is mounted on a HepcoMotion single edge ring slide ① which allows friction free rotation and provides control at the periphery adjacent to where the load is being applied. The large tooth form and width of the internal gear drive ② permits high transmission forces and ensures long life in this high speed indexing application.

## Application Examples

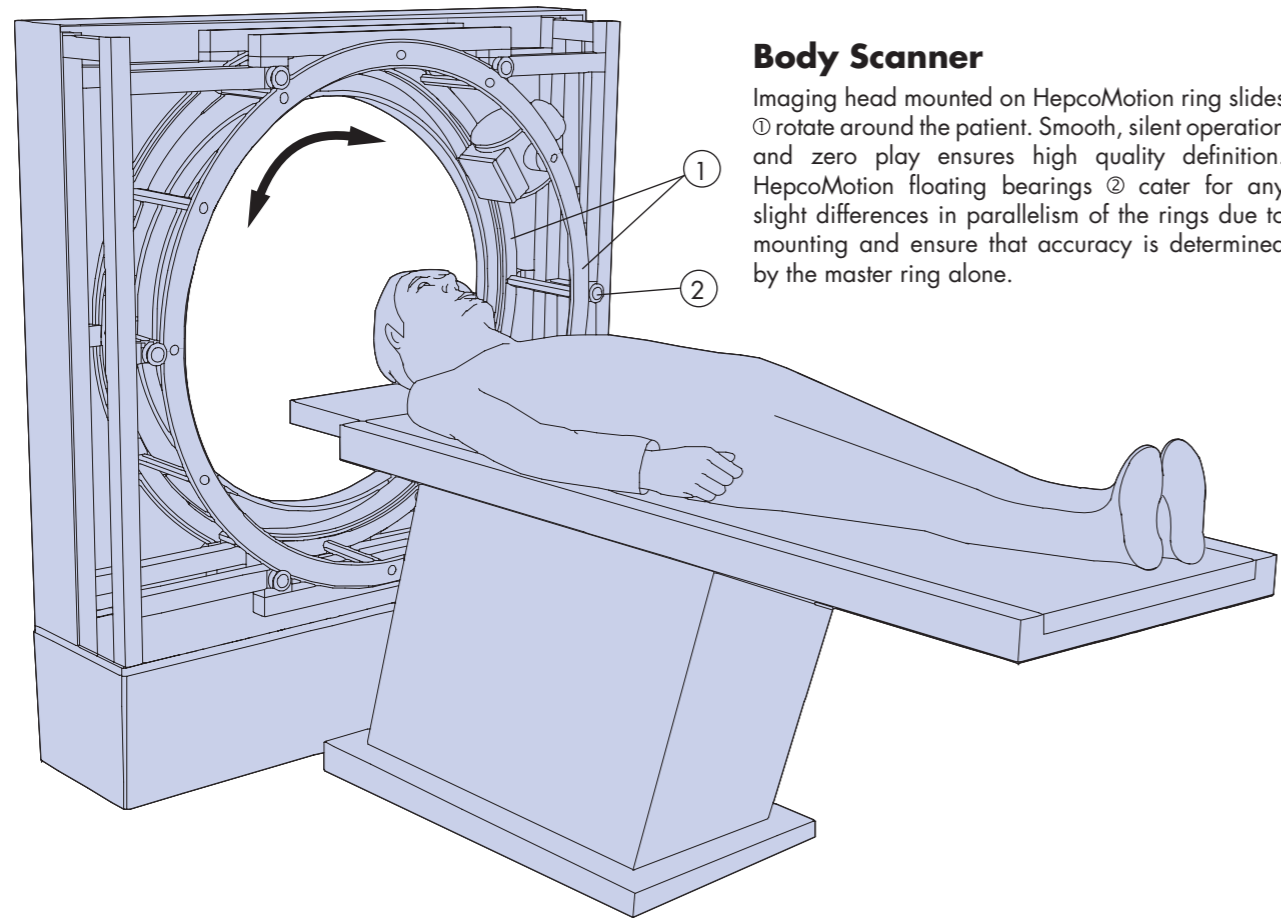

### Body Scanner

Imaging head mounted on HepcoMotion ring slides ① rotate around the patient. Smooth, silent operation and zero play ensures high quality definition. HepcoMotion floating bearings ② cater for any slight differences in parallelism of the rings due to mounting and ensure that accuracy is determined by the master ring alone.

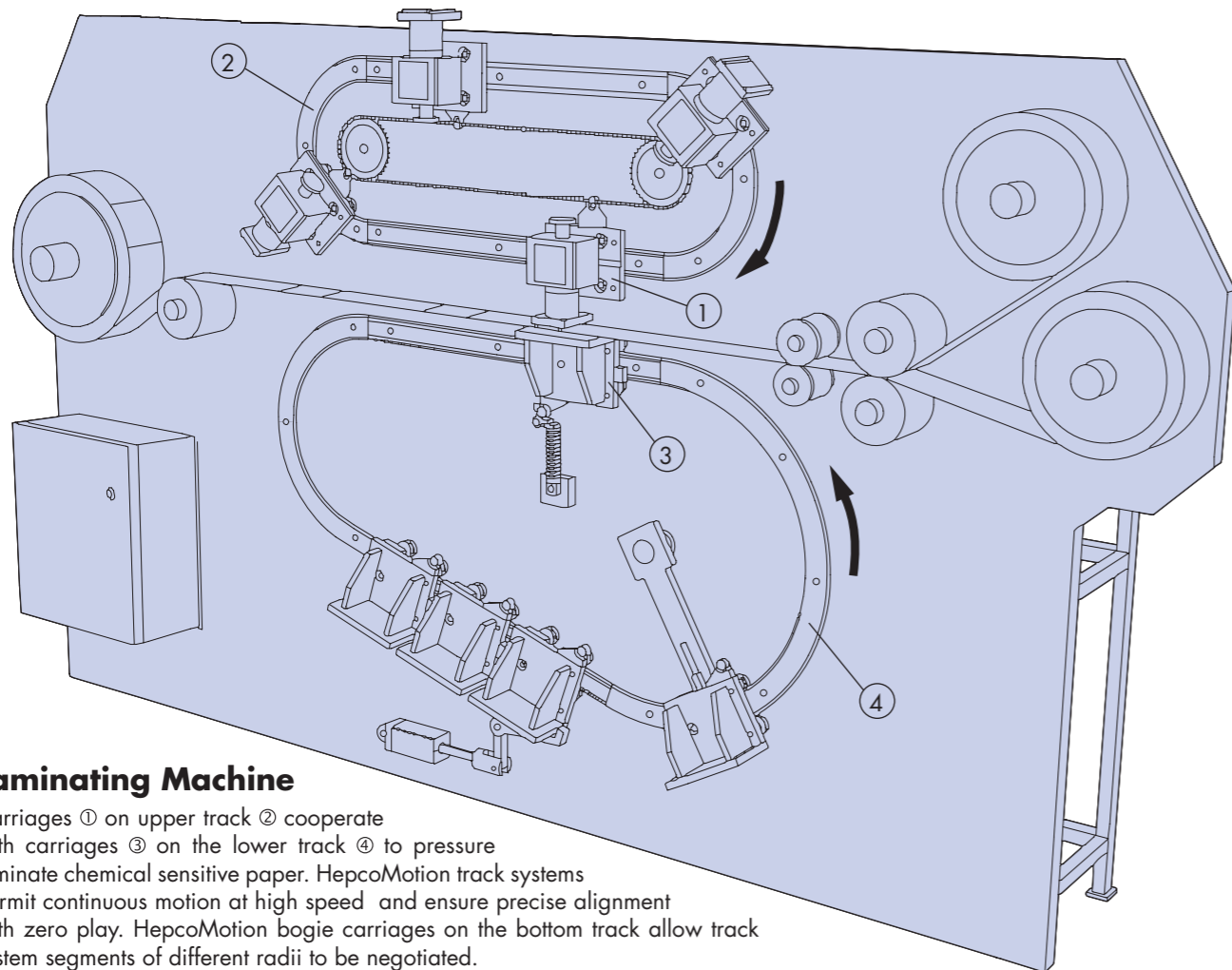

### Laminating Machine

Carriages ① on upper track ② cooperate with carriages ③ on the lower track ④ to pressure laminate chemical sensitive paper. HepcoMotion track systems permit continuous motion at high speed and ensure precise alignment with zero play. HepcoMotion bogie carriages on the bottom track allow track system segments of different radii to be negotiated.

## Application Examples

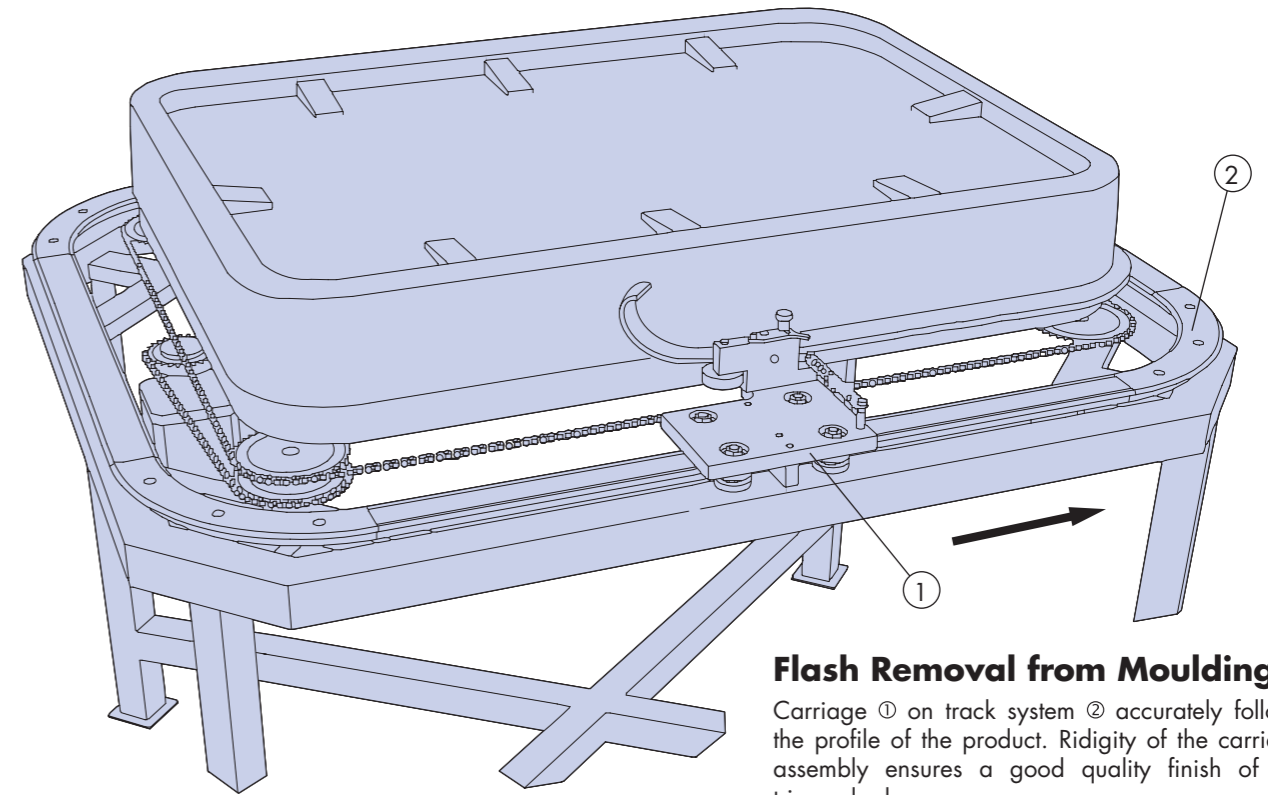

### Flash Removal from Moulding

Carriage ① on track system ② accurately follows the profile of the product. Rigidity of the carriage assembly ensures a good quality finish of the trimmed edge.

### Multi-Station Assembly Machine

Carriages linked by connecting rods ① are indexed around a track system circuit ② by means of a walking beam system operated by HepcoMotion GV3 straight slides ③. Zero play and precise positioning enables highly accurate work to take place at each station. Bogie carriages ④ provide a large platform for mounting the components.

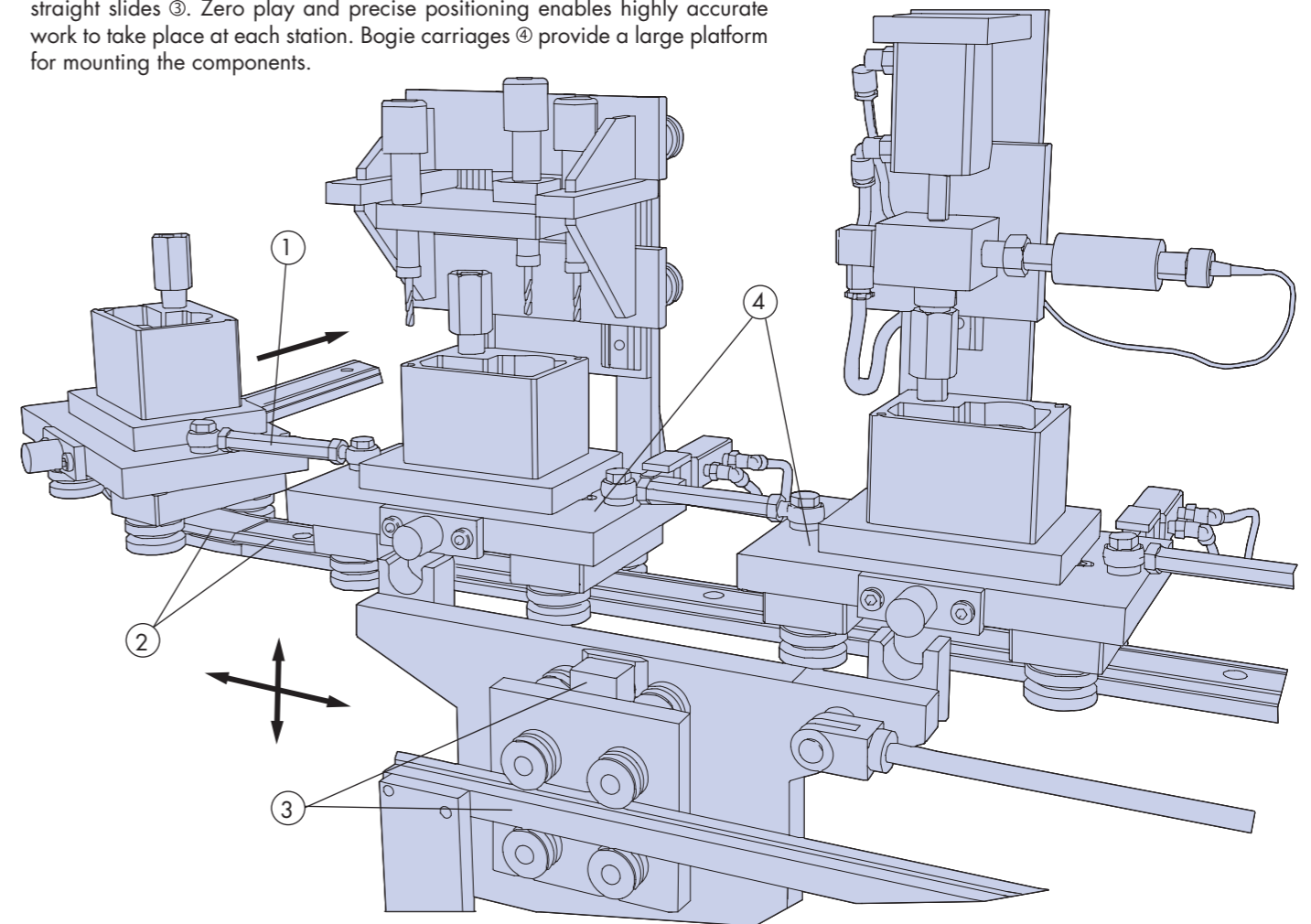

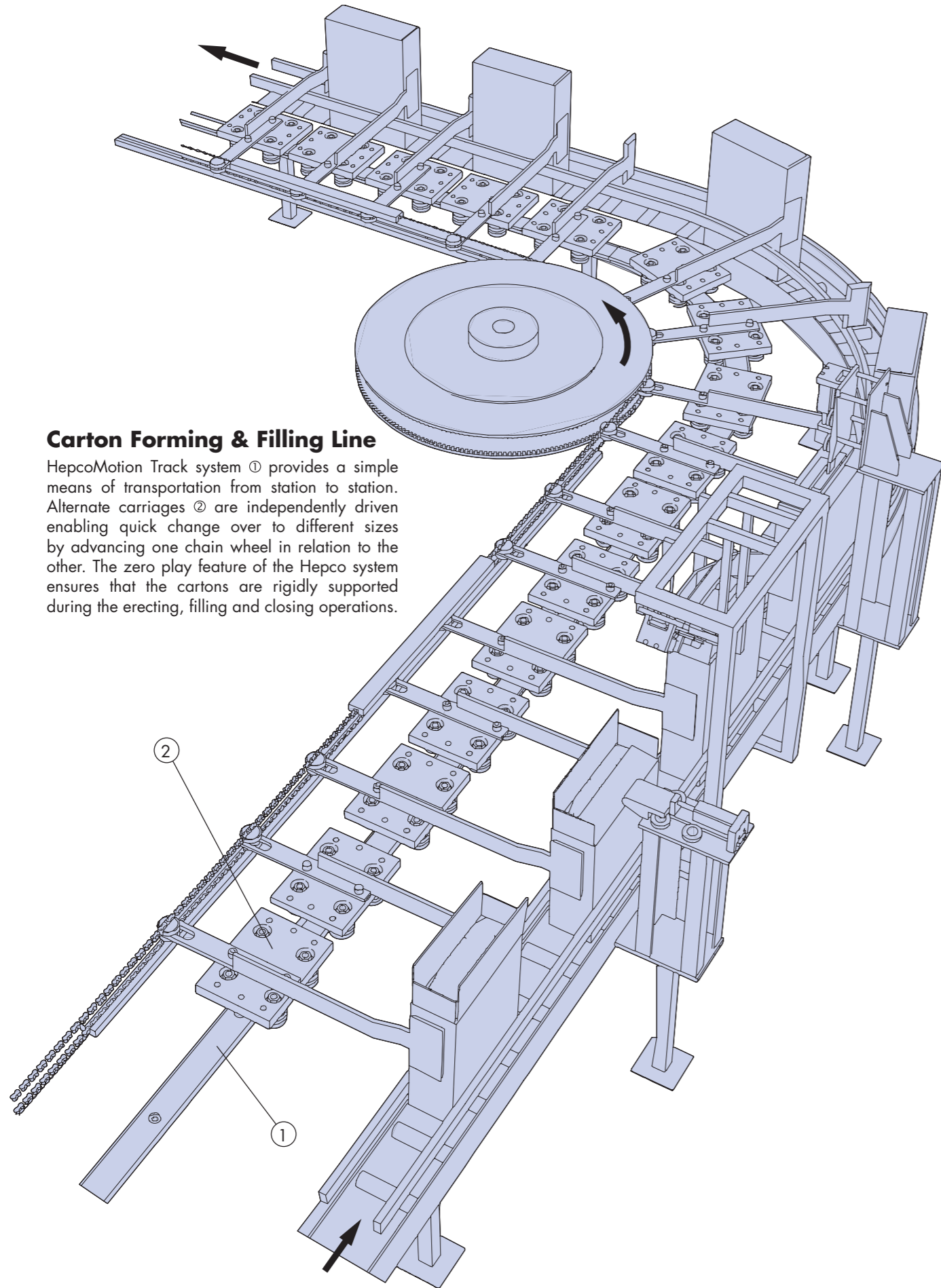

**Carton Forming & Filling Line**

HepcoMotion Track system ① provides a simple means of transportation from station to station. Alternate carriages ② are independently driven enabling quick change over to different sizes by advancing one chain wheel in relation to the other. The zero play feature of the Hepco system ensures that the cartons are rigidly supported during the erecting, filling and closing operations.

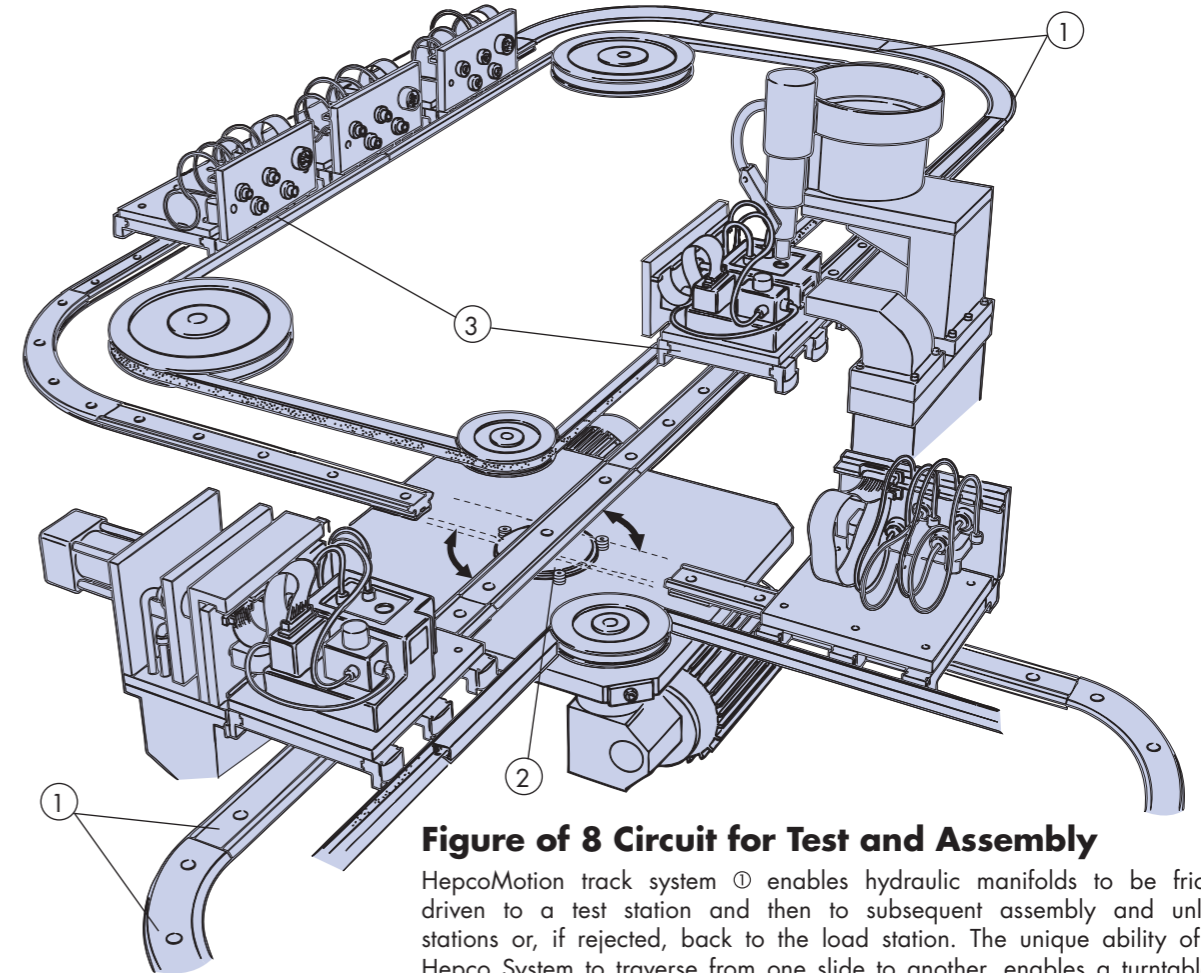

**Figure of 8 Circuit for Test and Assembly**

HepcoMotion track system ① enables hydraulic manifolds to be friction driven to a test station and then to subsequent assembly and unload stations or, if rejected, back to the load station. The unique ability of the Hepco System to traverse from one slide to another, enables a turntable to be designed at the crossover junction using a HepcoMotion ring disc ② to provide rotary movement. Bogie carriages ③ allow S bends to be traversed.

**Optical Lens Assembly**

Machine incorporates a standard HepcoMotion DTS complete driven track system for which there is a separate catalogue. See also 50 & 51.

Lenses are loaded by pick and place units onto clamp fixtures mounted on HepcoMotion carriages ①. Optical adhesive is applied between lenses before passing through ultra-violet light box to activate hardener. Precise positioning of carriages is required at work stations, this is achieved by means of the HepcoMotion carriage locking system ②.

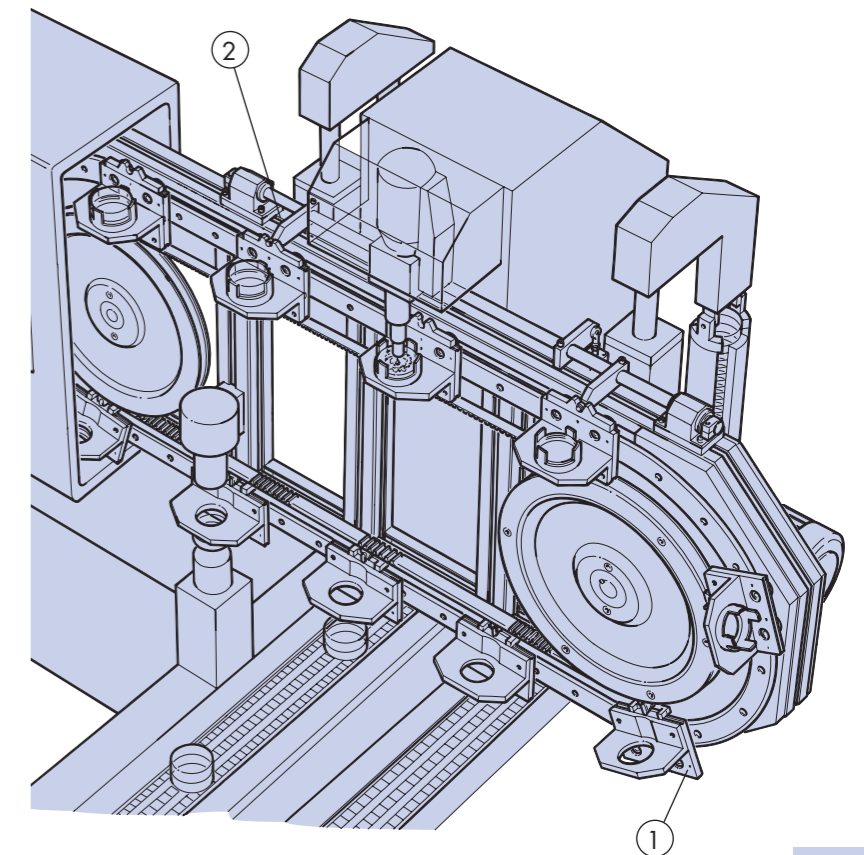



### Clamping Method for Belt to Carriage Connection

Carriages are connected to the belt by means of clamping device ①, resulting in a strong fixing which overcomes the need to screw through the belt. The pulleys must be machined to provide recesses ② in order to accommodate the clamps. The slip block method 19 should be used to adjust track system length in relation to the tensioned belt.

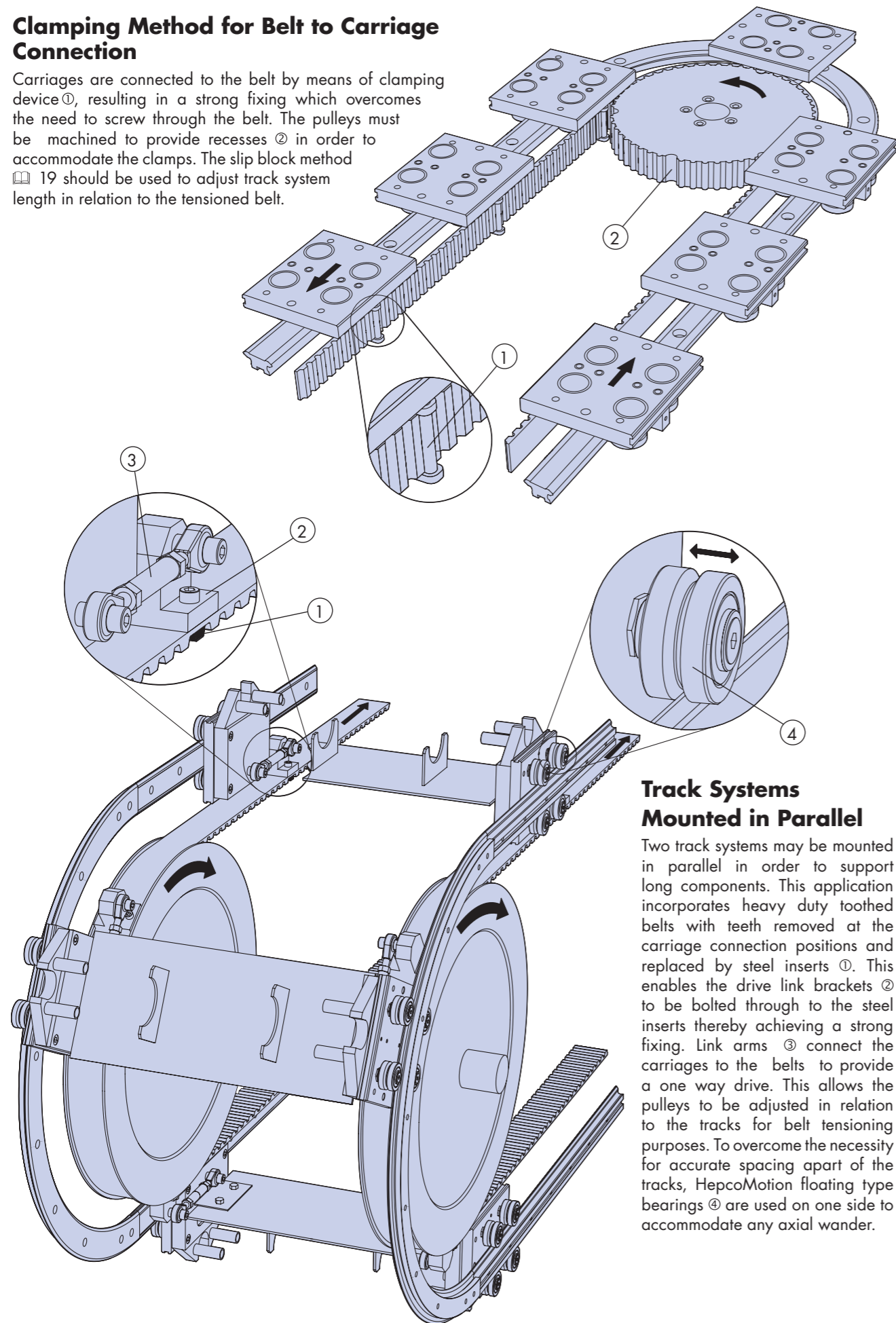

### Track Systems Mounted in Parallel

Two track systems may be mounted in parallel in order to support long components. This application incorporates heavy duty toothed belts with teeth removed at the carriage connection positions and replaced by steel inserts ①. This enables the drive link brackets ② to be bolted through to the steel inserts thereby achieving a strong fixing. Link arms ③ connect the carriages to the belts to provide a one way drive. This allows the pulleys to be adjusted in relation to the tracks for belt tensioning purposes. To overcome the necessity for accurate spacing apart of the tracks, HepcoMotion floating type bearings ④ are used on one side to accommodate any axial wander.

### Spider Drive

For short track systems carriages ① can be driven from a central motor and spider. The arms of the spider ② incorporate slots to accommodate the changing distance of the carriages from the motor drive shaft.

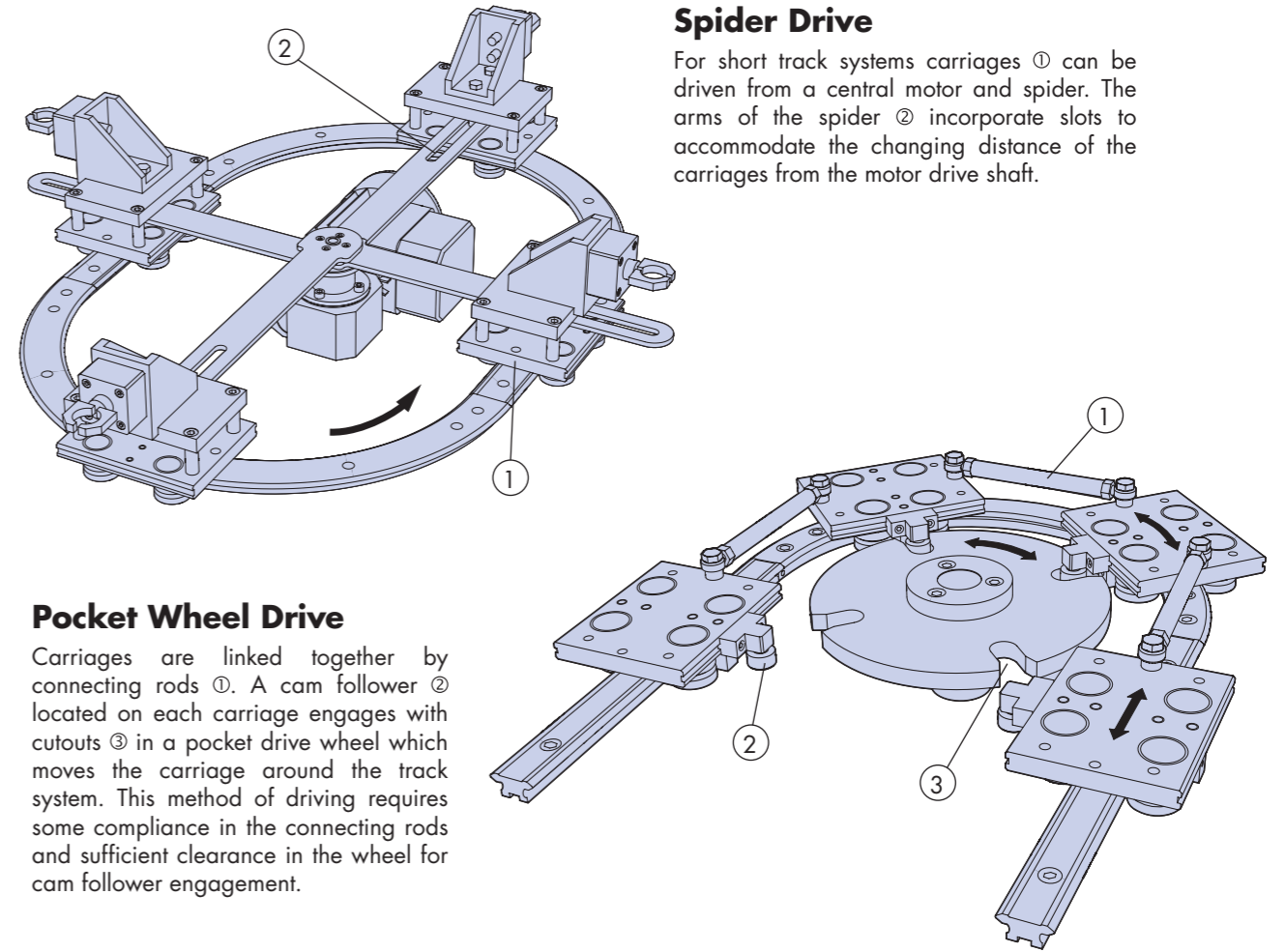

### Pocket Wheel Drive

Carriages are linked together by connecting rods ①. A cam follower ② located on each carriage engages with cutouts ③ in a pocket drive wheel which moves the carriage around the track system. This method of driving requires some compliance in the connecting rods and sufficient clearance in the wheel for cam follower engagement.

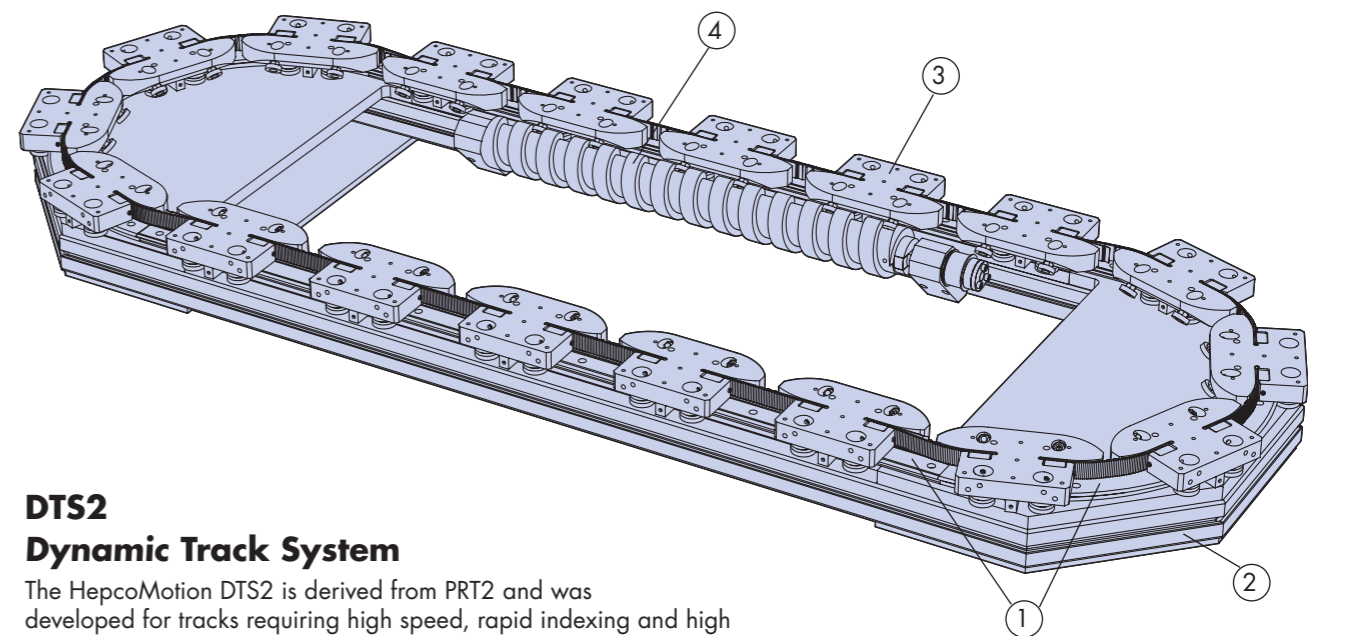

### DTS2 Dynamic Track System

The HepcoMotion DTS2 is derived from PRT2 and was developed for tracks requiring high speed, rapid indexing and high driving forces. It includes a PRT2 track ①, mounted on a Hepco MCS compatible frame ②. Its carriages ③, are linked with adjustable spring-loaded belts and driven by a screw ④. The DTS2 can be supplied with motors, drives and bleed lubrication system ( 52). DTS2 units can be oval as illustrated, rectangular, or have any other valid track layout without S-bends. A range of sizes is available, in either standard or corrosion resistant version.

A datasheet for DTS2 is included at [www.HepcoMotion.com/dts2datauk](http://www.HepcoMotion.com/dts2datauk).

### Slotted Carriage Connection For Belt Adjustment

The timing belt is fitted with U section attachments ① secured to the belt with countersunk screws. Pins ② engage with slotted drive member ③ which drives the carriage around the circuit. In this type of design whether using a belt or chain, it is important to provide a slot to allow for tension adjustment and also to cater for slight variation in the proximity of carriage to belt or chain, as the carriage traverses from straight to curve.

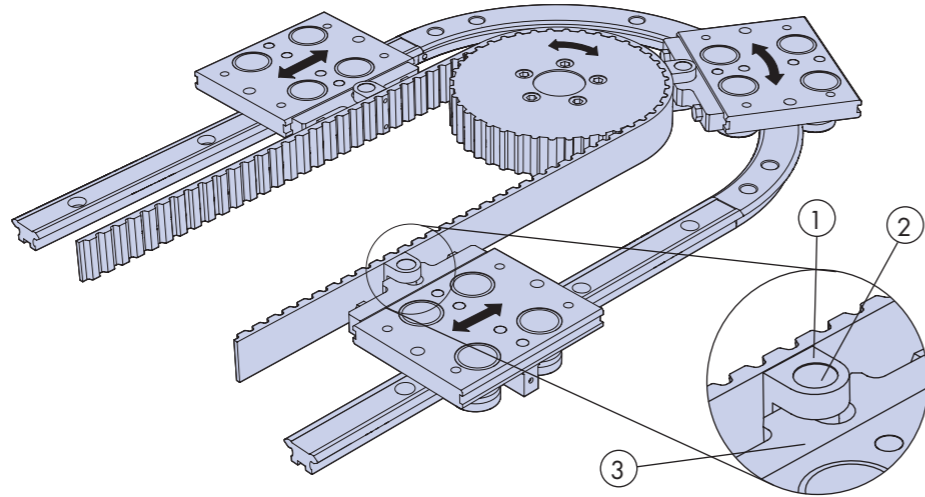

### Link Drive

A simple link arm ① pivoting on an extended pin, connects to the carriage and provides for a drive in a single direction only. The design allows an amount of chain adjustment to take place and caters for slight variation in the proximity of carriage to chain, as the carriage traverses from straight to curve. It is recommended that chain support rails ② are fitted to overcome the offset drive forces.

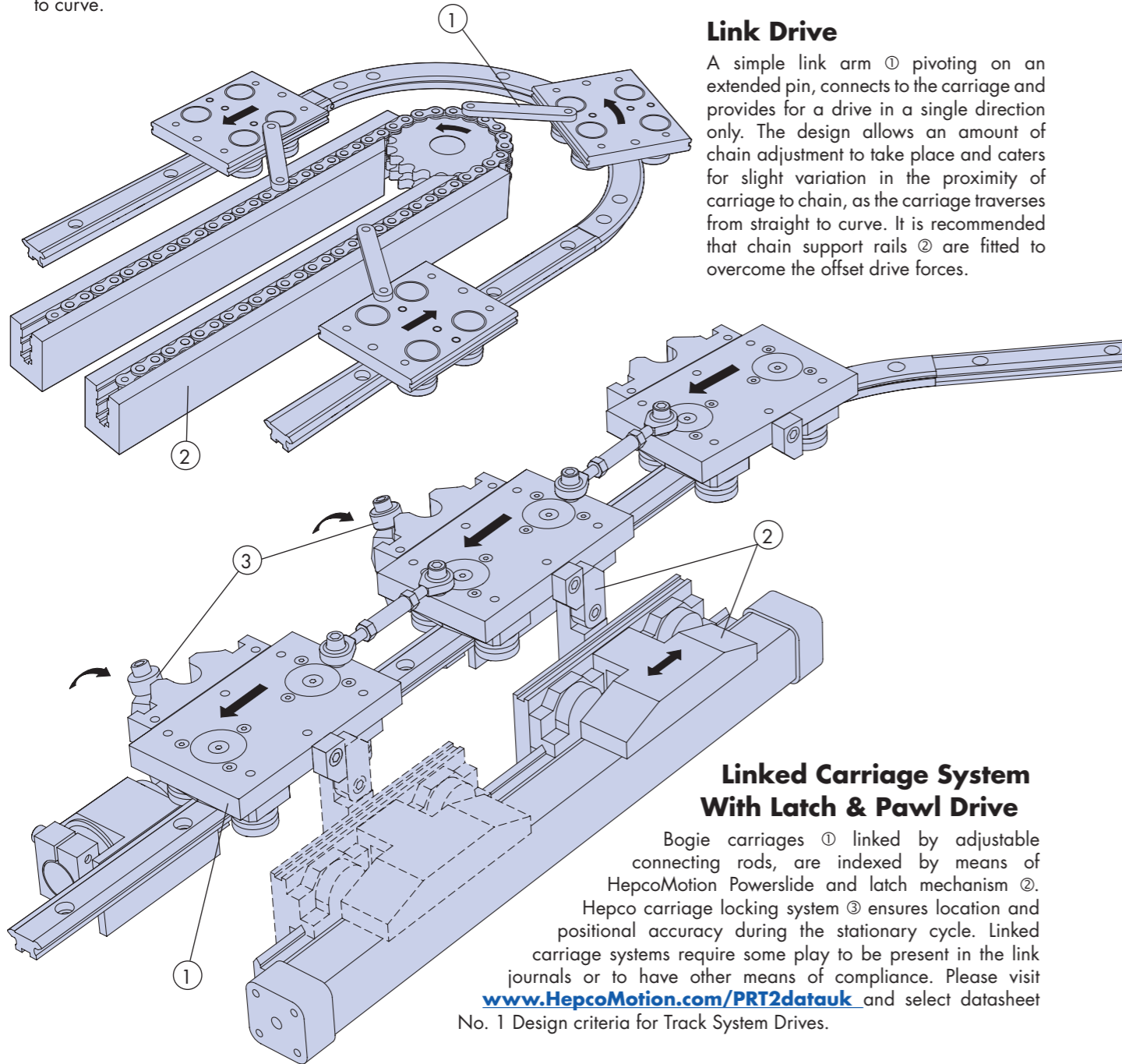

### Linked Carriage System With Latch & Pawl Drive

Bogie carriages ① linked by adjustable connecting rods, are indexed by means of HepcoMotion Powerslide and latch mechanism ②. Hepco carriage locking system ③ ensures location and positional accuracy during the stationary cycle. Linked carriage systems require some play to be present in the link journals or to have other means of compliance. Please visit [www.HepcoMotion.com/PRT2datauk](http://www.HepcoMotion.com/PRT2datauk) and select datasheet No. 1 Design criteria for Track System Drives.

### Linked Carriage System With Scroll Drive

Bogie carriages ① linked by adjustable connecting rods, incorporate rollers ② which engage with the screw ③ to provide either intermittent or continuous motion drive. Linked carriage systems require some play to be present in the link journals or to have other means of compliance. Please visit [www.HepcoMotion.com/PRT2datauk](http://www.HepcoMotion.com/PRT2datauk) and select datasheet No. Design criteria for Track System Drives.

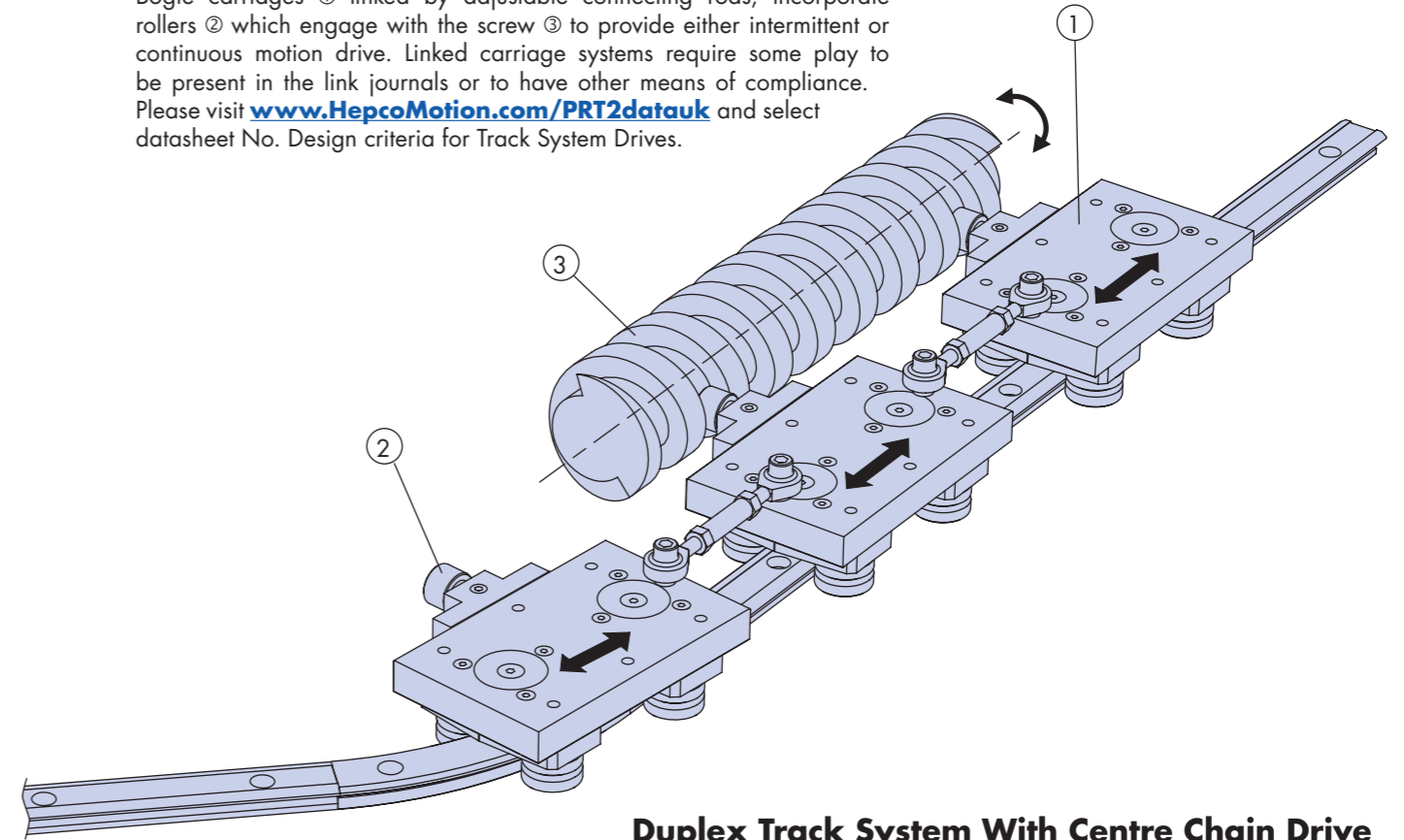

### Duplex Track System With Centre Chain Drive

This durable and highly stable duplex track system capable of withstanding high loads, is available complete with special chain and scroll drive system from Hepco. The track system comprises of duplex single edge slides ① and a central drive to ensure constant velocity around the circuit. Any number of carriages at virtually any spacing can be accommodated on the system which can be supplied complete with motor and mounted on a Hepco MCS frame. Chain adjustment is rarely required but is achieved by the slip block method ② as shown and further illustrated 19. Either intermittent or constant motion is possible in either direction. A unique mechanism within the carriage in conjunction with the carriage locking system ③ 50-51, enables index positioning to within 0.02mm to be achieved.

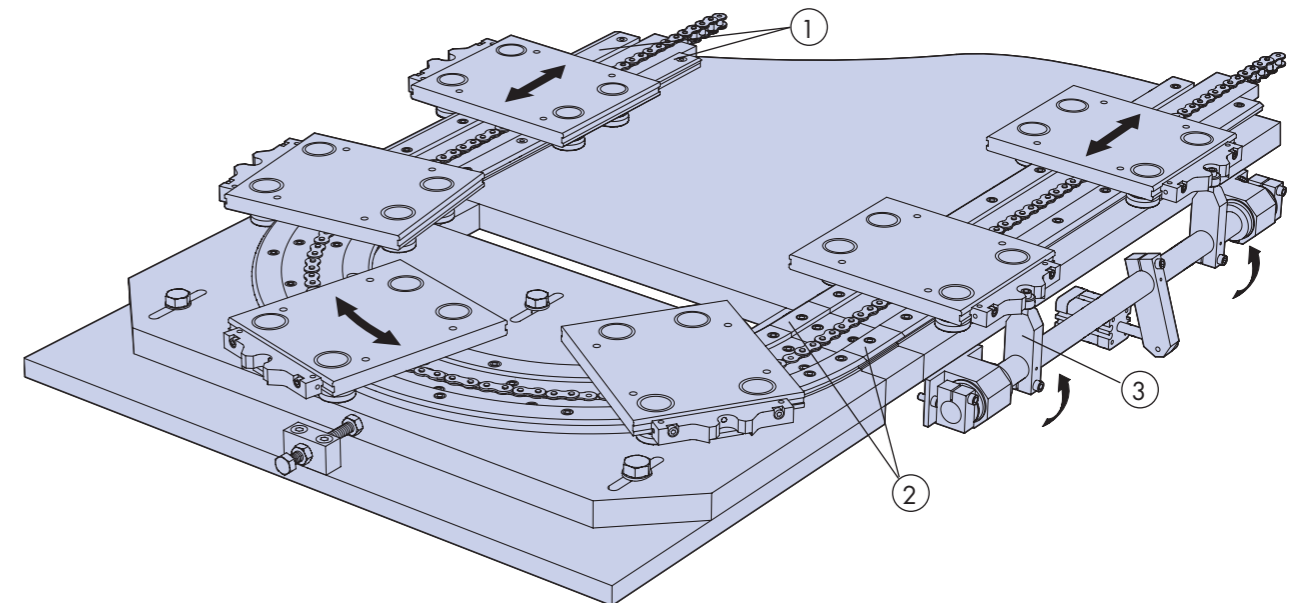

### Gear Driven Duplex Track System

Single edge track system with a gear drive on the inner curved and straight slides ①, engages with pinion ② driven from the motor. A sprung pivot arm ③ ensures that the pinion remains engaged with the rack as it travels from straight to curve. The system is a standard HepcoMotion design and can be supplied either in part or, as a complete system with motor as required.

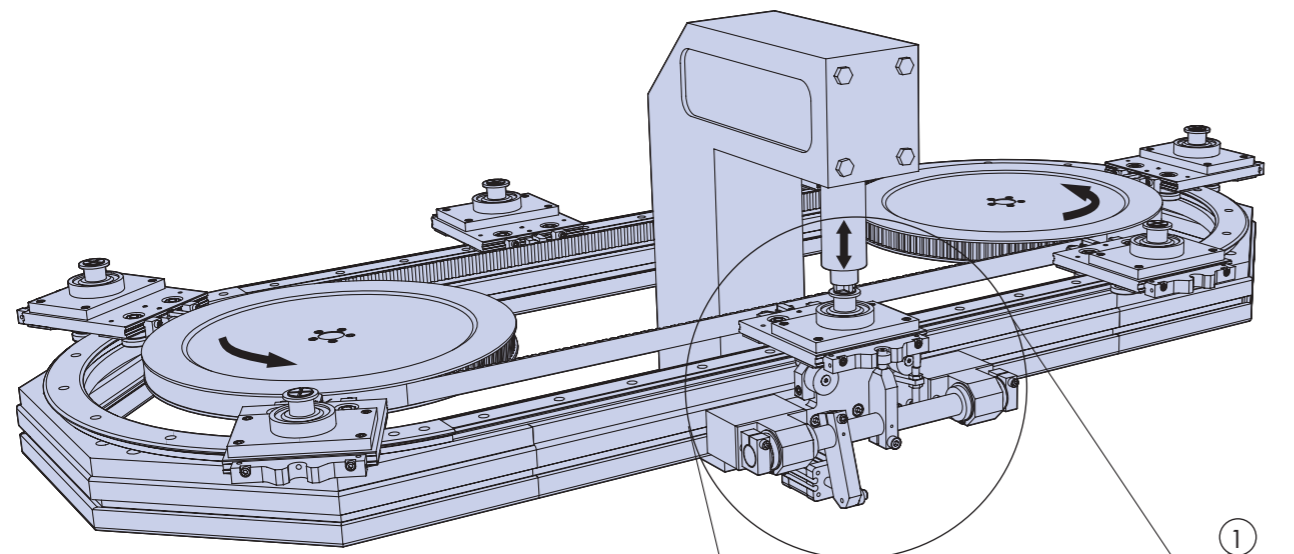
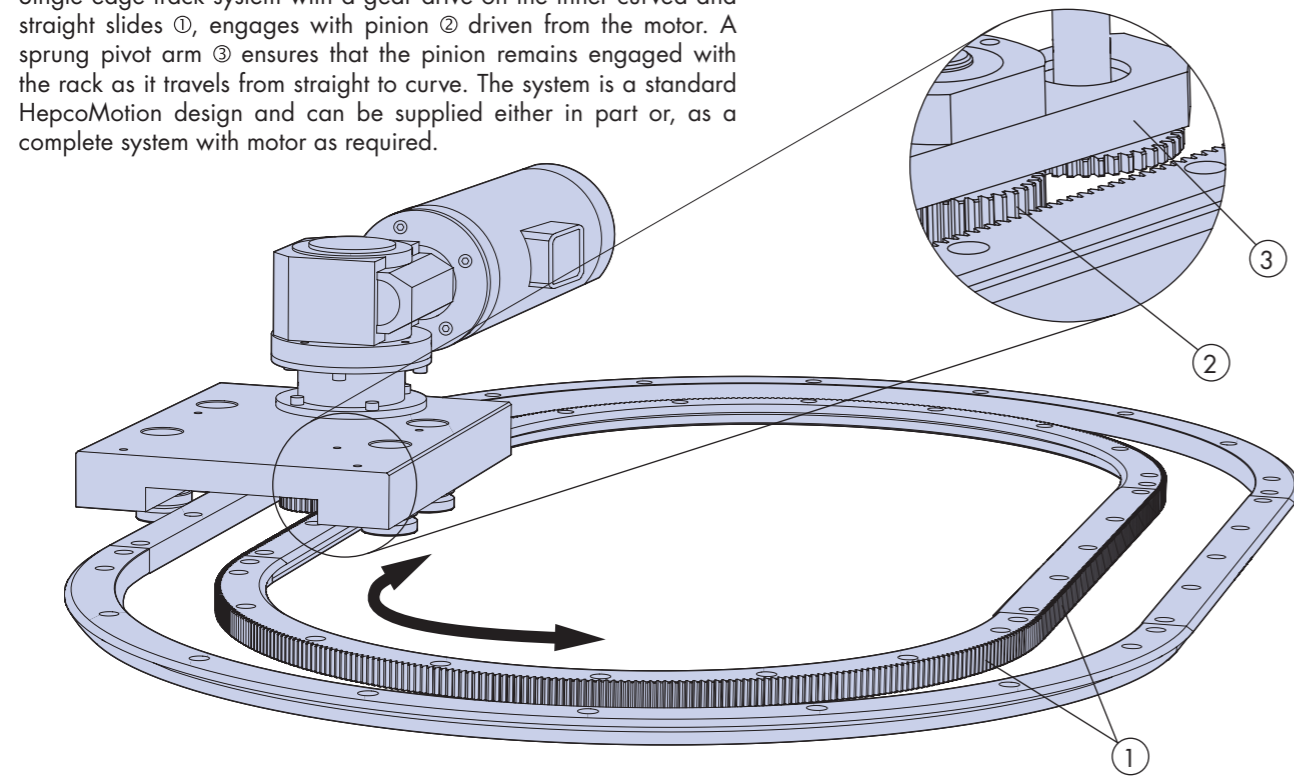

### Track System With Moment Load Carriage

In this standard HepcoMotion Driven Track System example a high downwards force is being applied to the carriage during a stamping operation. The moment load carriage ① and static roller support ② provides additional support whilst the force is being applied. A HepcoMotion carriage locking system ③ 50-51 ensures precise location and positional accuracy whilst the operation takes place.

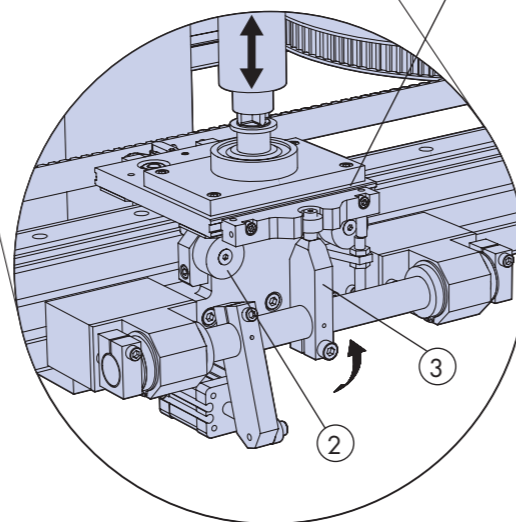

### Chain Tensioning for Long Track Systems

A track system driven by a chain or belt ideally requires a means of adjustment for pretensioning and to allow for subsequent wear and stretch, particularly in the case of a chain drive. Limited adjustment can be achieved by providing a slot at the chain to carriage connection point (see top illustration 16) or by link connection of chain to carriage (see centre illustration 16 and example below). However, in systems where a large amount of adjustment is anticipated or where the path of the belt or chain must follow in exact relationship to the path of the track, the Slip Block or Bridging methods of adjustment should be considered.

#### Slip Block Adjustment Method

Hepco can provide sets of short length straight slides in various increments of length, precisely matched to those on the track system and with square ground ends. Each slide will be marked according to its length. Slide support blocks can also be supplied to customer's drawing if required. Please visit [www.HepcoMotion.com/PRT2datauk](http://www.HepcoMotion.com/PRT2datauk) and select datasheet No.10 Slip Block adjustment method.

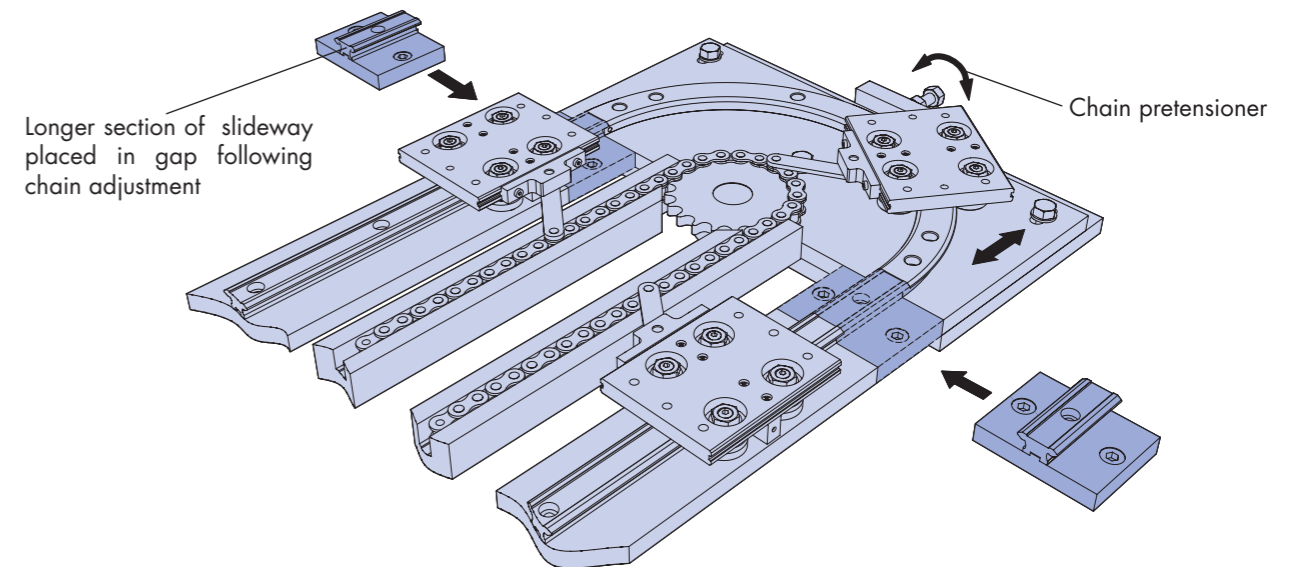

#### Bridging Slide Adjustment Method

The bridging slide arrangement enables the track to be extended following adjustment of the chain drive whilst maintaining continuity of guidance and control. In order to traverse the adjustment gap, the bearings have external chamfers on the outside diameter in addition to the normal central V. The bridging slide arrangement comprises of three fixed slideways and one adjustable slideway, see illustrations below. All components comprising the bridging slide arrangement and special bearings can be readily supplied. Please advise total amount of slide adjustment required.

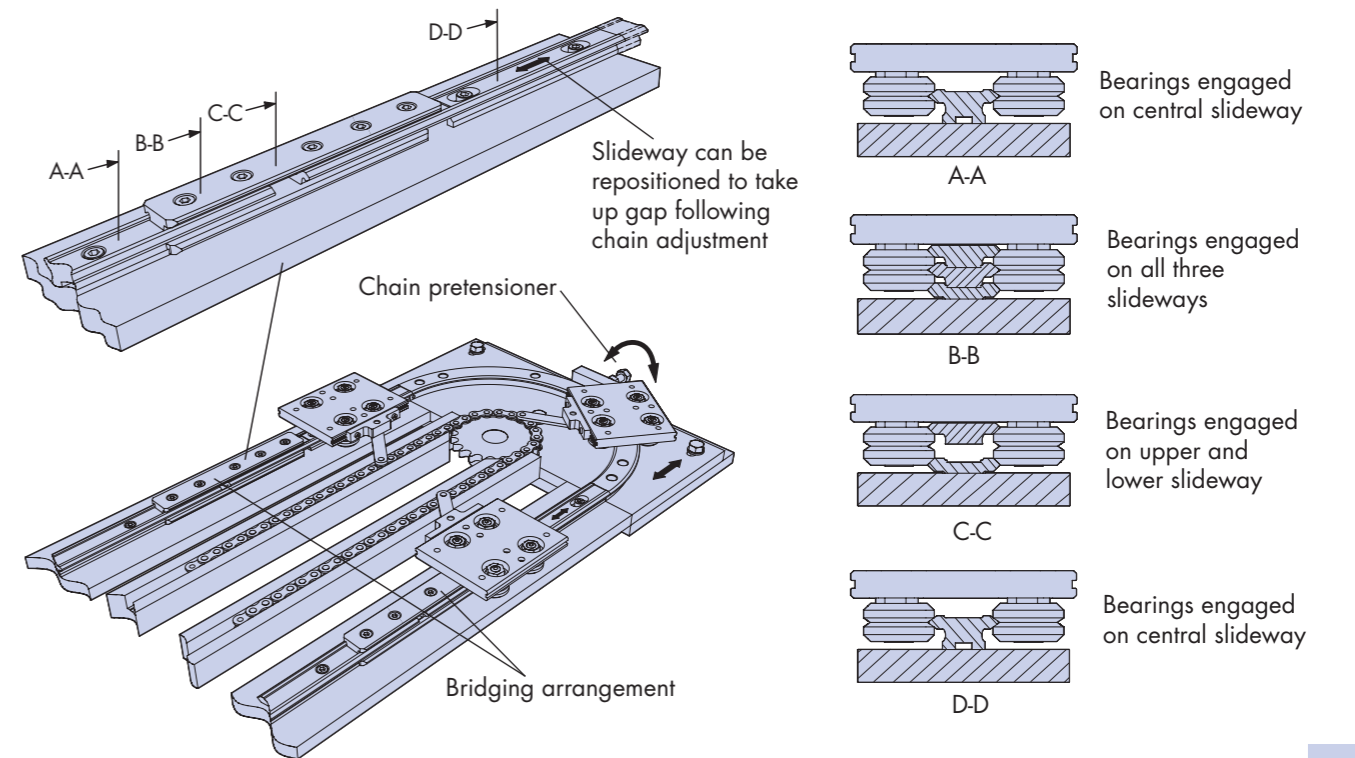

## Full Size Illustrations For Initial Selection

Full size illustrations of the basic range of Ring slide systems together with a comparison table for bearings and lubrication are provided to help with initial selection. Customers should refer to the individual component pages for dimensions and to the Technical section for details of load and life. There is a wide range of other options and components complementary to those shown in this section. These are illustrated in the System Composition 2.7 and throughout the catalogue.

Bearing	Load		Speed	Smoothness	Tolerance of Misalignment		Ridgity	Tolerance of Debris		Price
					☹	☺		☹	☺	
Twin Bearing 	☹	☹	☺	☺	☹	☺	☹	☺	☺	☹
Double Row Bearing 	☹	☹	☺	☺	☹	☺	☹	☺	☺	☹
Floating Bearing 	☹	☹	☺	☺	☹	☺	☹	☺	☺	☹

Lubrication Method	Load		Lubrication interval		Friction		Life		Price	
	☹	☺	☹	☺	☹	☺	☹	☺	☹	☺
None	☹	☹	☹	☹	☹	☹	☹	☹	☹	☹
Hepco Lubricator 	☹	☹	☺	☺	☹	☺	☺	☺	☹	☹
Hepco Bleed Lubrication 	☹	☹	Automatic lube frequency possible		☹	☺	☺	☺	☹	☹

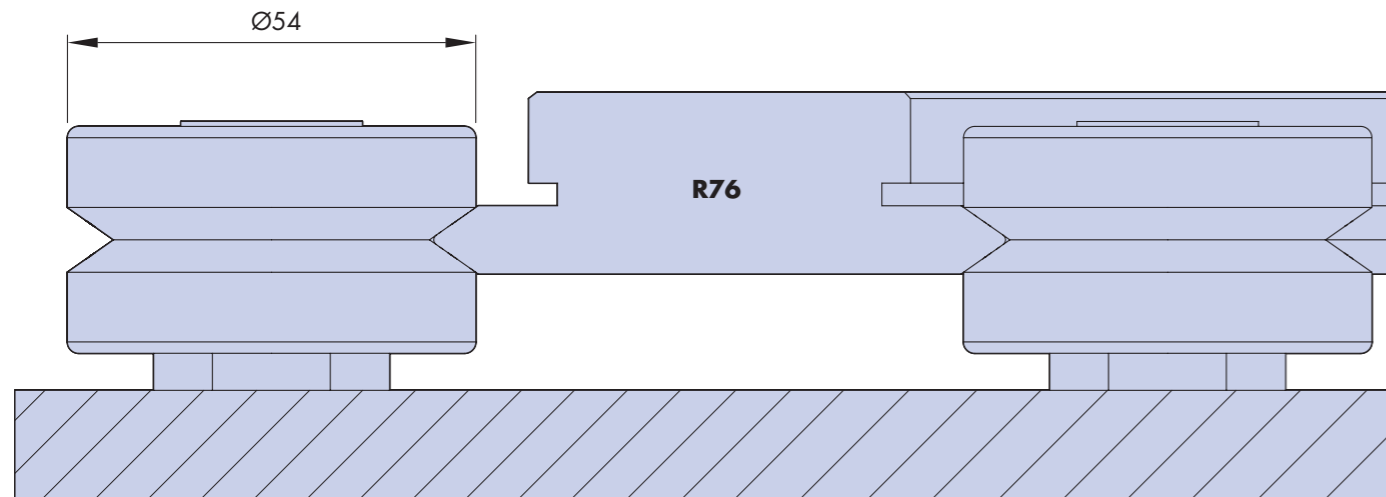

## Full Size Illustrations For Initial Selection

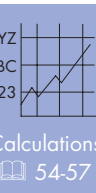
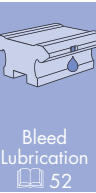
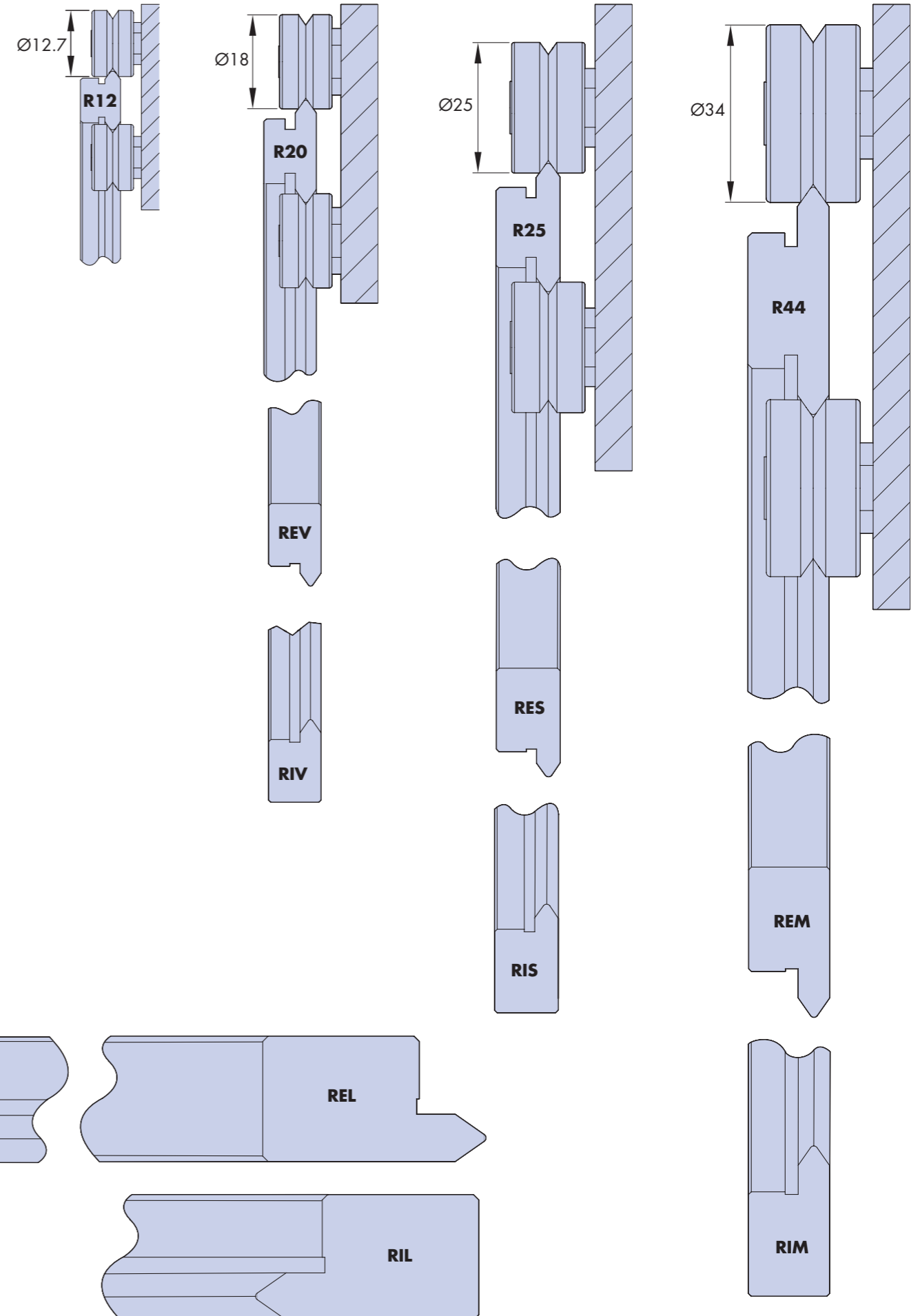

## Assembled Double Edge Ring System

The HepcoMotion double edge ring system with carriage may be used in either complete ring form or with segments. It can also be combined with straight slides to form a track system 40-44.

Rings may also be encircled by bearings either externally and/or internally with either ring or bearings being the moving element (see page opposite). The HepcoMotion PRT2 eccentric bearings are of double eccentric design with sufficient throw to enable disengagement of the carriage or encircled ring, without further disassembly.

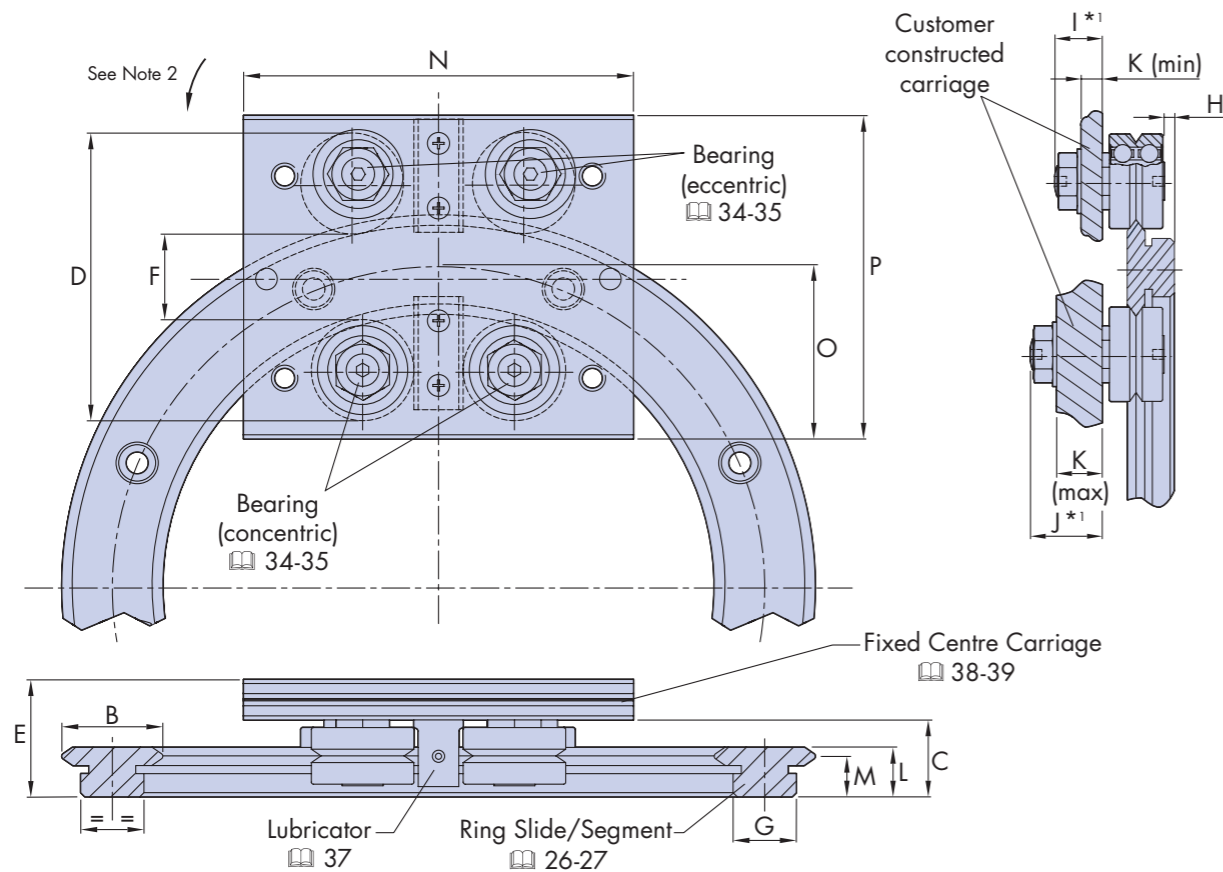

## Assembled Double Edge Ring System

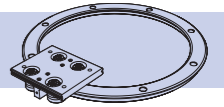

When using HepcoMotion Double Edge Ring Slides encircled by bearings as shown below it is recommended that two concentric bearings should be placed 120° apart in order to provide a datum reference. The other bearings should be the eccentric type. All eccentrics may be used where positional adjustment of the ring is required.

One or more lubricators may be fitted at convenient positions to take advantage of the increased load/life afforded by lubrication 55-57.

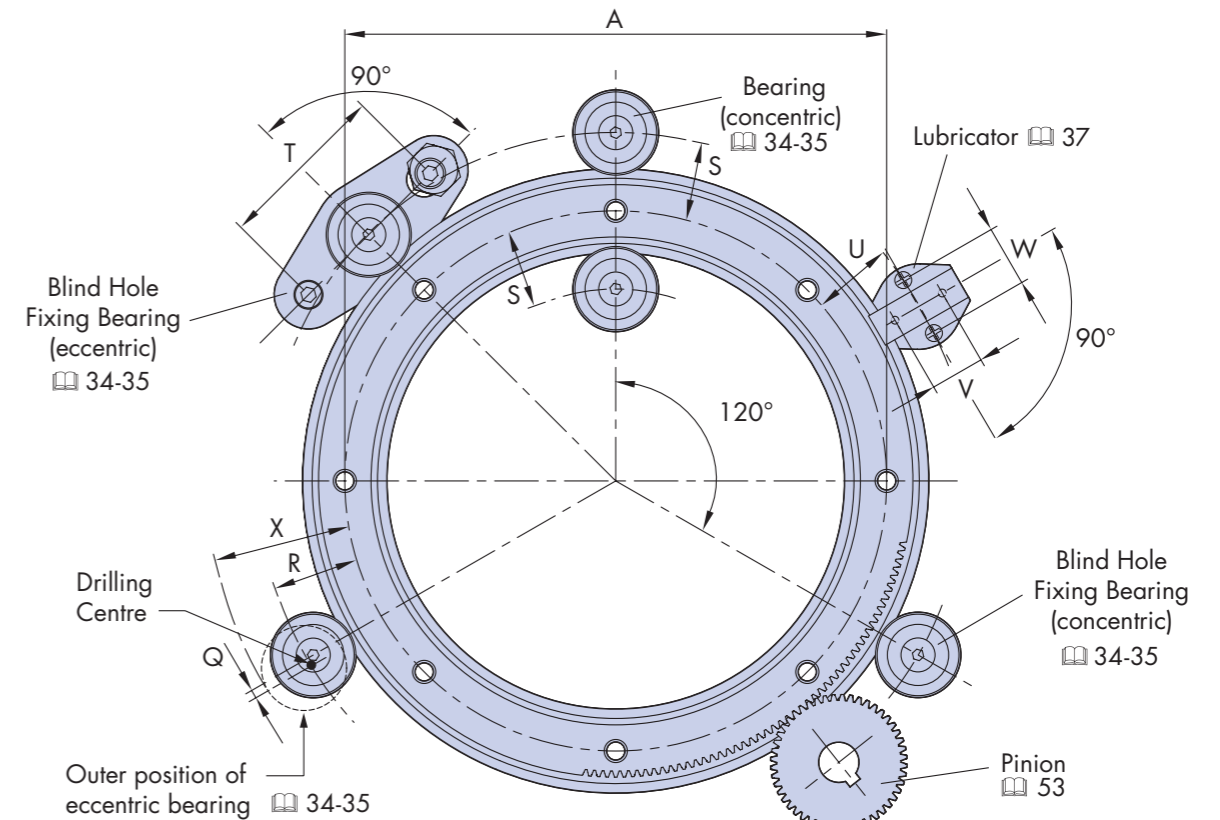

Ring Slide Ref No	For use with bearing (Ø)	A	B	C	D	E	F	G	H	I <sup>1</sup>	J <sup>1</sup>	K		L	M	N	O	P	Drilling Positions <sup>3</sup>						X	
												Max	Min						Q	R	S	T ±0.2	U ±0.2	V ±0.2		W ±0.2
R12 93	... J13 ...	93	12	11.67	34.7	19.0	9.1	8.6	1.5	5.8	9.5	6.7	2.2	7.7	6.2	55	22	40	1.3	12.3	10.9	30	11.5	6.5	12	20.5
R12 127	... J13 ...	127	12	11.67	34.7	19.0	9.1	8.6	1.5	5.8	9.5	6.7	2.2	7.7	6.2	55	21	40	1.3	12.3	10.9	30	11.5	6.5	12	20.5
R20 143	... J18 ...	143	20	14.75	52.5	24.75	16.3	12.4	2.4	7.4	14	10	2.4	10	8	75	34	64	1.8	19	17.2	38	18	13	13	30.6
R20 210	... J18 ...	210	20	14.75	52.5	24.75	16.3	12.4	2.4	7.4	14	10	2.4	10	8	80	34	64	1.8	19	17.2	38	18	13	13	30.6
R25 159	... J25 ...	159	25	19	71.2	30.5	20.9	15.4	2.4	9.8	19	13	2.2	12.25	10	95	43	80	1.9	24.9	23.0	50	22.5	16	18	40.2
R25 255	... J25 ...	255	25	19	71.2	30.5	20.9	15.4	2.4	9.8	19	13	2.2	12.25	10	100	42	80	1.9	24.9	23.0	50	22.5	16	18	40.2
R25 351	... J25 ...	351	25	19	71.2	30.5	20.9	15.4	2.4	9.8	19	13	2.2	12.25	10	105	42	80	1.9	24.9	23.0	50	22.5	16	18	40.2
R44 468	... J34 ...	468	44	24	106.0	38.5	37.8	26	2.7	13.8	22	14.8	5.2	15.5	12.5	145	61	116	2.5	38.5	35.9	60	34.5	22	25	59.1
R44 612	... J34 ...	612	44	24	106.0	38.5	37.8	26	2.7	13.8	22	14.8	5.2	15.5	12.5	150	61	116	2.5	38.5	35.9	60	34.5	22	25	59.1
R76 799	... J54 ...	799	76	38.5	172.8	58.5	64.4	50.5	3.8	17.8	30	20.4	5.7	24	19.5	190	96	185	3.9	63.1	59.2	89.5	57	33	38	95.6
R76 1033	... J54 ...	1033	76	38.5	172.8	58.5	64.4	50.5	3.8	17.8	30	20.4	5.7	24	19.5	210	96	185	3.9	63.1	59.2	89.5	57	33	38	95.6
R76 1267	... J54 ...	1267	76	38.5	172.8	58.5	64.4	50.5	3.8	17.8	30	20.4	5.7	24	19.5	250	97	185	3.9	63.1	59.2	89.5	57	33	38	95.6
R76 1501	... J54 ...	1501	76	38.5	172.8	58.5	64.4	50.5	3.8	17.8	30	20.4	5.7	24	19.5	270	97	185	3.9	63.1	59.2	89.5	57	33	38	95.6

### Notes:

- Two lengths of stud are available for each size of bearing 34-35. Choose according to required carriage thickness.
- Offset holes in carriage for eccentric bearings necessitate adjustment in direction of arrow shown see 58.
- Exact theoretical values have been given for 'Q', 'R' and 'S'. Positional accuracy of dimension 'S' will determine the axis of the ring. Positional accuracy for dimensions 'Q' and 'R' are not normally critical. Holes for bearing studs should be reamed to tolerance F6 for a sliding fit.

### Ordering details:

Simply list the components required and if relevant, bracket those you wish to be factory assembled.

**Example:** Assembled { 1 x R25 159 R180 ——— 180° Ring segment 26-27  
1 x FCC 25 159 ——— Fixed centre carriage 38-39

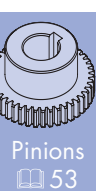
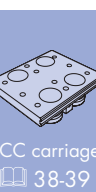

## Assembled Single Edge Ring System (External)

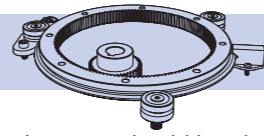

When using HepcoMotion external single edge ring slides it is recommended that two concentric bearings should be placed 120° apart in order to provide a datum reference. The other bearings should be eccentric type. All eccentrics may be used where positional adjustment of the ring is required. Either ring or bearings can be the moving element. The HepcoMotion PRT2 eccentric bearings are of double eccentric design with sufficient throw to enable disengagement of the ring without disassembly. One or more lubricators may be fitted at convenient positions to take advantage of the increased load/life afforded by lubrication 54-57.

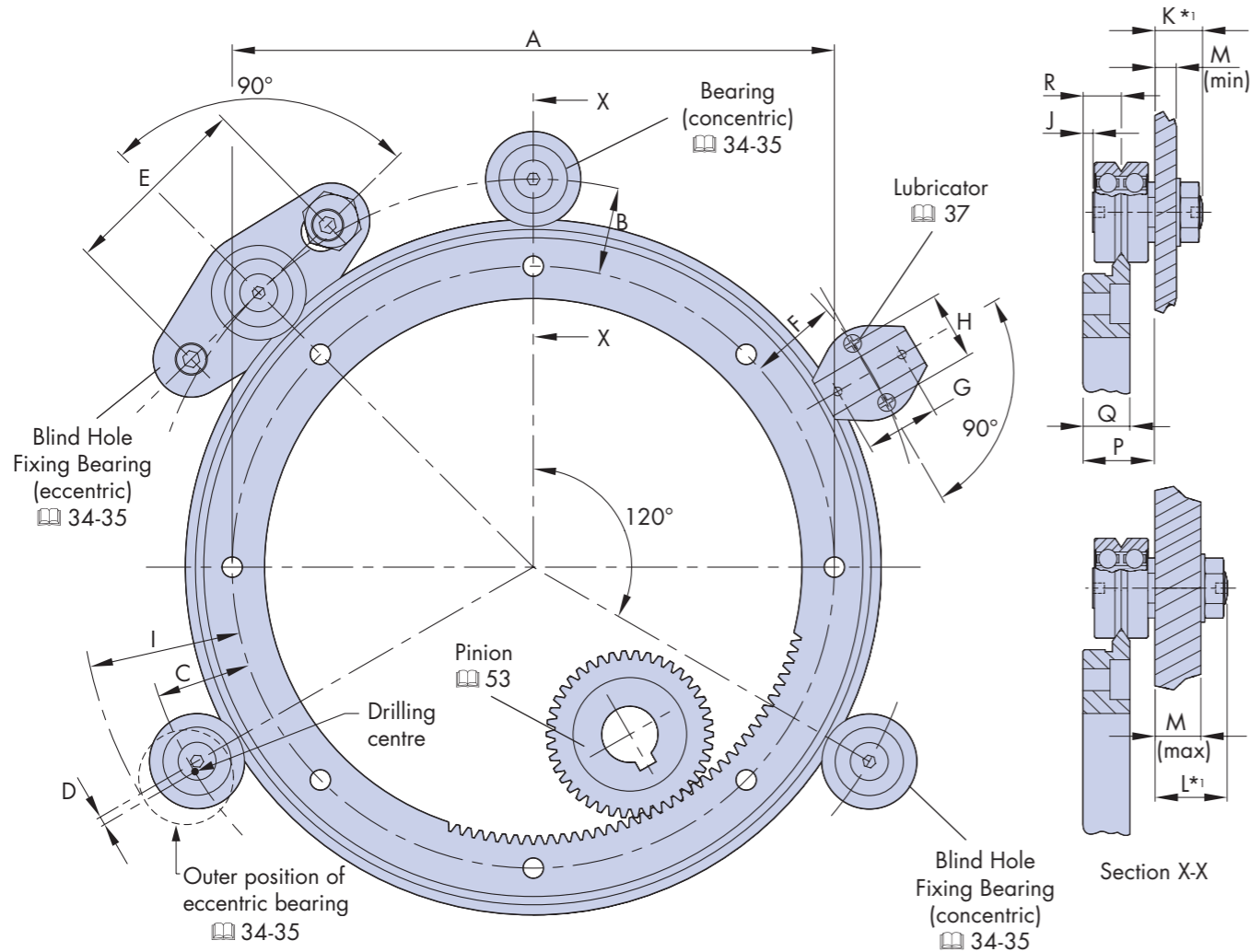

Ring Slide Ref No	For use with bearing (Ø)	A	Drilling Positions <sup>2</sup>								I	J	K <sup>1</sup>	L <sup>1</sup>	M		P	Q	R
			B	C	D	E	F	G	H	Max					Min				
REV 156	... J18 ...	137.6	16.7	18.5	1.8	38	17.5	13	13	30.1	2.4	7.4	14	10	2.4	14.75	10	8	
REV 223	... J18 ...	204.8	16.7	18.5	1.8	38	17.5	13	13	30.1	2.4	7.4	14	10	2.4	14.75	10	8	
RES 184	... J25 ...	159	23.0	24.9	1.9	50	22.5	16	18	40.2	2.4	9.8	19	13	2.2	19	12.25	10	
RES 280	... J25 ...	255	23.0	24.9	1.9	50	22.5	16	18	40.2	2.4	9.8	19	13	2.2	19	12.25	10	
RES 376	... J25 ...	351	23.0	24.9	1.9	50	22.5	16	18	40.2	2.4	9.8	19	13	2.2	19	12.25	10	
REM 505	... J34 ...	468.5	32.4	35	2.5	60	31	22	25	55.6	2.7	13.8	22	14.8	5.2	24	15.5	12.5	
REM 655	... J34 ...	618.5	32.4	35	2.5	60	31	22	25	55.6	2.7	13.8	22	14.8	5.2	24	15.5	12.5	
REL 874	... J54 ...	820	48.3	52.1	3.9	89.5	45.5	33	38	84.6	3.8	17.8	30	20.4	5.7	38.5	24	19.5	

### Notes:

- Short or long stud lengths are available for each size of bearing 34-35. Choose according to the required mounting plate thickness.
- Exact theoretical values have been given for 'B', 'C' and 'D'. Positional accuracy of dimension 'B' will determine the axis of the ring. Positional accuracy for dimensions 'C' and 'D' are not normally critical. Holes for bearing studs should be reamed to tolerance F6 for a sliding fit.

## Assembled Single Edge Ring System (Internal)

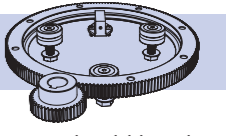

When using HepcoMotion internal single edge ring slides it is recommended that two concentric bearings should be placed 120° apart in order to provide a datum reference. The other bearings should be eccentric type. All eccentrics can be used where positional adjustment of the ring is required. Either ring or bearings may be the moving element. The HepcoMotion PRT2 eccentric bearings are of double eccentric design with sufficient throw to enable disengagement of the ring, without further disassembly. One or more lubricators may be fitted at convenient positions to take advantage of the increased load/life afforded by lubrication 54-57.

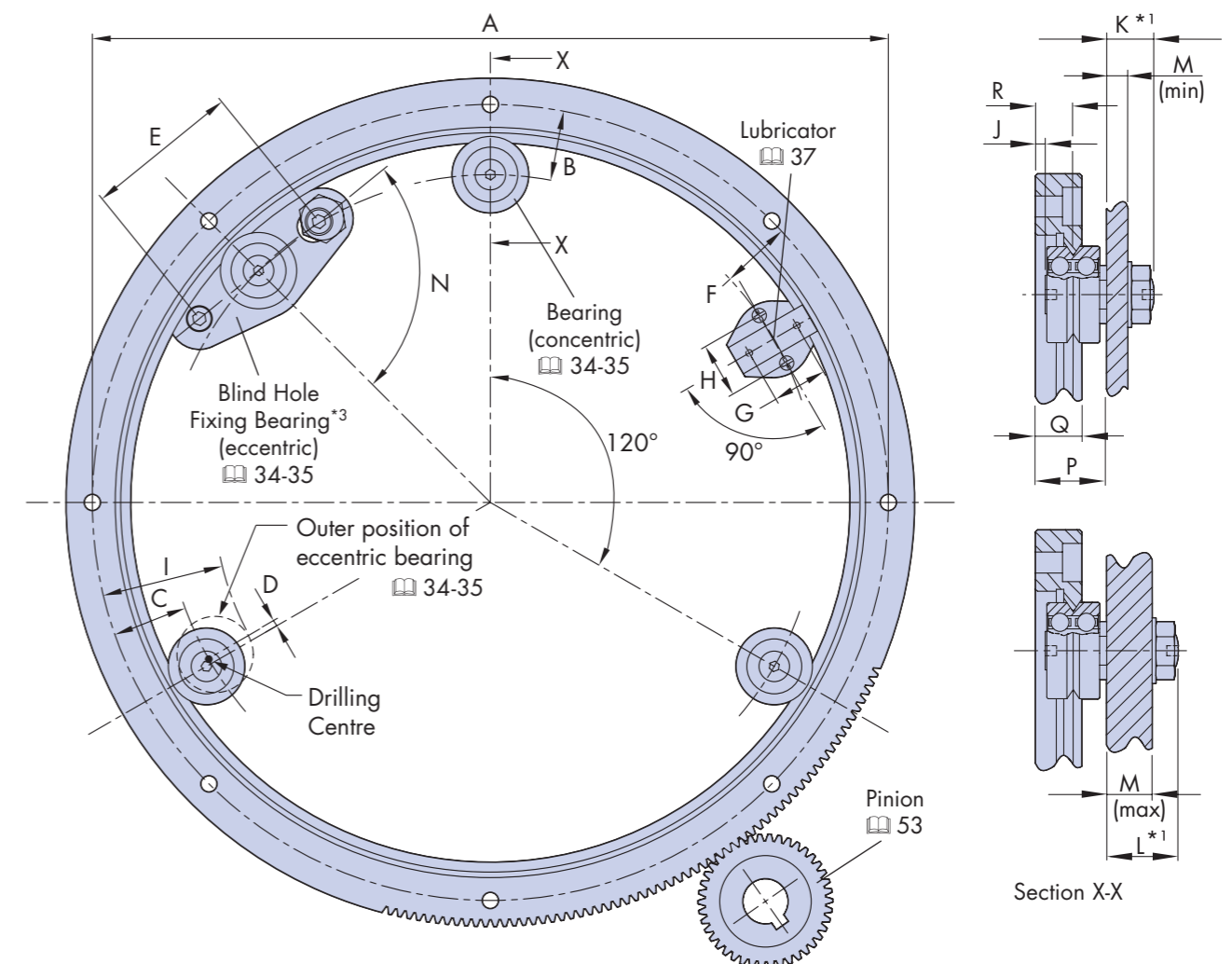

Ring Slide Ref No	For use with bearing (Ø)	A	Drilling Positions <sup>3</sup>								I	J	K <sup>1</sup>	L <sup>1</sup>	M		N	P	Q	R
			B	C	D	E	F	G	H	Max					Min					
RIV 161	... J18 ...	148	16.7	18.5	1.8	38	17.5	13	13	30.1	2.4	7.4	14	10	2.4	90	14.75	10	8	
RIV 228	... J18 ...	215.2	16.7	18.5	1.8	38	17.5	13	13	30.1	2.4	7.4	14	10	2.4	86	14.75	10	8	
RIS 182 <sup>3</sup>	... J25 ...	165	23.0	24.9	1.9	-	22.5	16	18	40.2	2.4	9.8	19	13	2.2	-	19	12.25	10	
RIS 278	... J25 ...	261	23.0	24.9	1.9	50	22.5	16	18	40.2	2.4	9.8	19	13	2.2	84	19	12.25	10	
RIS 374	... J25 ...	357	23.0	24.9	1.9	50	22.5	16	18	40.2	2.4	9.8	19	13	2.2	84	19	12.25	10	
RIM 482	... J34 ...	461.5	32.4	35	2.5	60	31	22	25	55.6	2.7	13.8	22	14.8	5.2	90	24	15.5	12.5	
RIM 627	... J34 ...	606.5	32.4	35	2.5	60	31	22	25	55.6	2.7	13.8	22	14.8	5.2	90	24	15.5	12.5	
RIL 820	... J54 ...	788	48.3	52.1	3.9	89.5	45.5	33	38	84.6	3.8	17.8	30	20.4	5.7	90	38.5	24	19.5	

### Notes:

- Short or long stud lengths are available for each size of bearing 34-35. Choose according to the required mounting plate thickness.
- Exact theoretical values have been given for 'B', 'C' and 'D'. Positional accuracy of dimension 'B' will determine the axis of the ring. Positional accuracy for dimensions 'C' and 'D' are not normally critical. Holes for bearing studs should be reamed to tolerance F6 for a sliding fit.
- The eccentric blind hole fixing bearing cannot be used with the RIS 182 ring slide as it clashes with the ring.

-  Ring slides 28-31
-  Bearings 34-36
-  Lubricators 37
-  Pinions 53
-  Calculations 54-57

# Double Edge Ring Slides & Segments



HepcoMotion double edge ring slides are manufactured from high quality steel, zone hardened on the V edges and precision ground all over with datum register faces provided both internally and externally for ease of location. Gear drive options are available with teeth machined into either the internal or external register face. The number of teeth on the standard external option is divisible by 4 and 12 in order to provide maximum choice of pinion size for exact ratio requirements. Customers may also choose the tapped hole option 'N' which enables the ring slide to be bolted from below. Stainless steel ring slides and segments are available for customers requiring corrosion resistance.

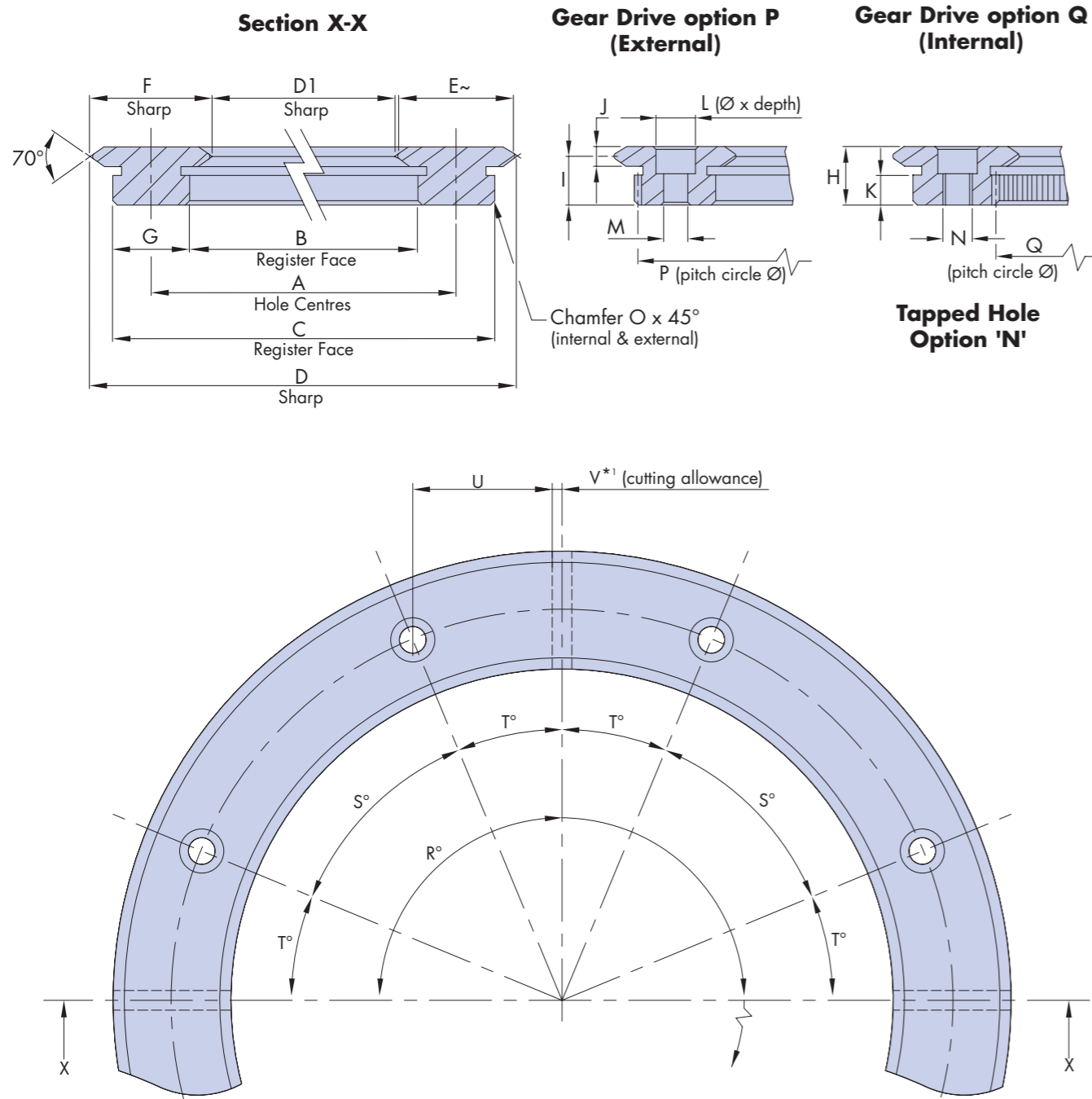

### Notes:

- Standard ring segments will be slightly less than 90° and 180° because of the cutting allowance. Full 90° and 180° segments can be supplied to customer's special order.
- Socket head cap screws DIN912 will protrude 1mm above the surface of the R12 and R20 section slide rings. Customers requiring screws to be flush should use low head type DIN7984, available from Hepco upon request.

# Double Edge Ring Slides & Segments

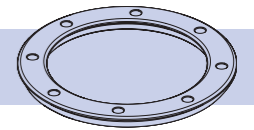

HepcoMotion double edge ring segments are cut from complete 360° ring slides and held in stock in nominal 90° and 180° segments<sup>1</sup>. Any length segment can be cut to customer's special order and additional holes drilled as required. Although suitable for most applications, slight out of roundness and flatness may be experienced with slide rings and segments in their free unmounted condition. This may be overcome by installing against a register and bolting to a flat surface, True shape rings and segments are available on request. Please visit [www.HepcoMotion.com/PRT2datauk](http://www.HepcoMotion.com/PRT2datauk) and select datasheet No. 9 True Shape Rings & Segments.

Part Number	For use with bearing (2)	A ±0.2	B (J56) Register Ø	C Register Ø	D	D1	E ~	F	G	H	I ±0.025	J	K	L	M	DIN912 <sup>2</sup> Not supplied
R12 93	... J13 ...	93	84.4 ±0.011	101.6 ±0.037	105.37	80.63	12	12.37	8.6	7.7	6.2	3	3.5	6 x 3	3.7	M3 <sup>2</sup>
R12 127	... J13 ...	127	118.4 ±0.011	135.6 ±0.037	139.37	114.63	12	12.37	8.6	7.7	6.2	3	3.5	6 x 3	3.7	M3 <sup>2</sup>
R20 143	... J18 ...	143	130.6 ±0.013	155.4 ±0.037	163.37	122.63	20	20.37	12.4	10	8	4.2	3.8	8 x 3.5	5.0	M4
R20 210	... J18 ...	210	197.6 ±0.015	222.4 ±0.037	230.37	189.63	20	20.37	12.4	10	8	4.2	3.8	8 x 3.5	5.0	M4
R25 159	... J25 ...	159	143.6 ±0.013	174.4 ±0.039	184.74	133.26	25	25.74	15.4	12.25	10	4.5	5.75	9 x 6	5.5	M5
R25 255	... J25 ...	255	239.6 ±0.015	270.4 ±0.041	280.74	229.26	25	25.74	15.4	12.25	10	4.5	5.75	9 x 6	5.5	M5
R25 351	... J25 ...	351	335.6 ±0.018	366.4 ±0.044	376.74	325.26	25	25.74	15.4	12.25	10	4.5	5.75	9 x 6	5.5	M5
R44 468	... J34 ...	468	442 ±0.020	494 ±0.046	512.74	423.26	44	44.74	26	15.5	12.5	6	7	11 x 7	6.8	M6
R44 612	... J34 ...	612	586 ±0.022	638 ±0.048	656.74	567.26	44	44.74	26	15.5	12.5	6	7	11 x 7	6.8	M6
R76 799	... J54 ...	799	748.5 ±0.025	849.5 ±0.051	875.74	722.26	76	76.74	50.5	24	19.5	9	12	20 x 13	14	M12
R76 1033	... J54 ...	1033	982.5 ±0.028	1083.5 ±0.054	1109.74	956.26	76	76.74	50.5	24	19.5	9	12	20 x 13	14	M12
R76 1267	... J54 ...	1267	1216.5 ±0.033	1317.5 ±0.057	1343.74	1190.26	76	76.74	50.5	24	19.5	9	12	20 x 13	14	M12
R76 1501	... J54 ...	1501	1450.5 ±0.039	1551.5 ±0.060	1577.74	1424.26	76	76.74	50.5	24	19.5	9	12	20 x 13	14	M12

N	O	External Gear			Internal Gear			Stock Segments <sup>1</sup>		Number of holes (R=360°)	Holes within ±0.2 of true position		U	V	kg (R=360°)	Part Number	
		P	MOD	No of teeth (R=360°)	Q	MOD	No of teeth (R=360°)	R°	S°		T°						
M4	0.2	100.8	0.4	252	85.2	0.4	213	90	180	360	8	45	22.5	16.8	1	0.16	R12 93
M4	0.2	134.4	0.4	336	119.2	0.4	298	90	180	360	8	45	22.5	23.3	1	0.22	R12 127
M6	0.4	153.6	0.8	192	132	0.8	165	90	180	360	8	45	22.5	26.3	1	0.45	R20 143
M6	0.4	220.8	0.8	276	199.2	0.8	249	90	180	360	8	45	22.5	39.2	1	0.66	R20 210
M8	0.5	172.8	0.8	216	145.6	0.8	182	90	180	360	8	45	22.5	29.4	1	0.77	R25 159
M8	0.5	268.8	0.8	336	241.6	0.8	302	90	180	360	8	45	22.5	47.8	1	1.2	R25 255
M8	0.5	364.8	0.8	456	337.6	0.8	422	90	180	360	12	30	15	44.4	1	1.65	R25 351
M8	0.5	492	1.0	492	444	1.0	444	90	180	360	12	30	15	58.6	2	5.1	R44 468
M8	0.5	636	1.0	636	588	1.0	588	90	180	360	16	22.5	11.25	57.7	2	6.7	R44 612
M16	1.0	846	1.5	564	751.5	1.5	501	90	180	360	16	22.5	11.25	75.9	2	25	R76 799
M16	1.0	1080	1.5	720	985.5	1.5	657	90	180	360	20	18	9	78.8	2	32	R76 1033
M16	1.0	1314	1.5	876	1219.5	1.5	813	90	180	360	20	18	9	97.1	2	41	R76 1267
M16	1.0	1548	1.5	1032	1453.5	1.5	969	90	180	360	20	18	9	115.4	2	48.7	R76 1501

### Ordering details:

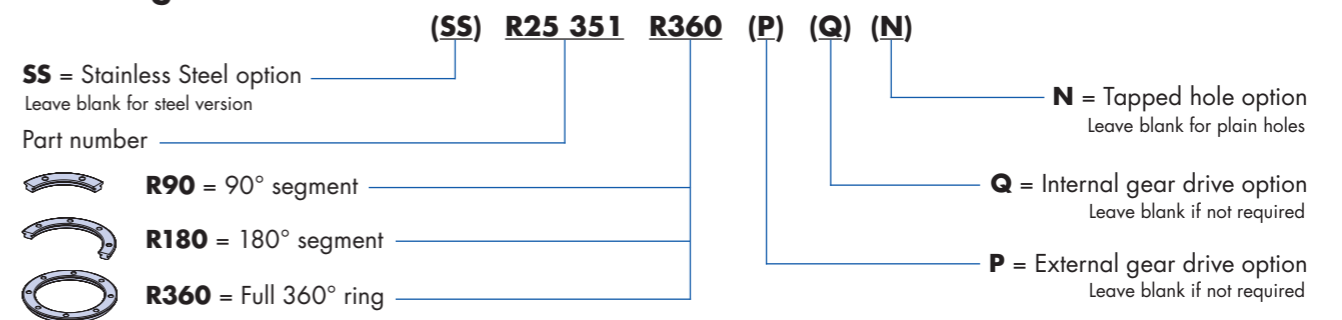

Assembled Systems 22-23

Bearings 34-36

Lubricators 37

FCC carriage 38-39

Pinions 53

Calculations 54-57

# External Single Edge Ring Slides & Segments



HepcoMotion single edge ring slides are manufactured from high quality steel, zone hardened on the V edge and precision ground all over. Datum register faces are provided both internally and externally for ease of location. Gear drive options are available with teeth machined into the internal register face. The number of teeth is divisible by 4 and 12 in order to provide maximum choice of pinion size for exact ratio requirements. Customers may also choose the tapped hole option 'N' which enables the ring slide to be bolted from below. Stainless steel ring slides and segments are available for customers requiring corrosion resistance.

**Section X-X**

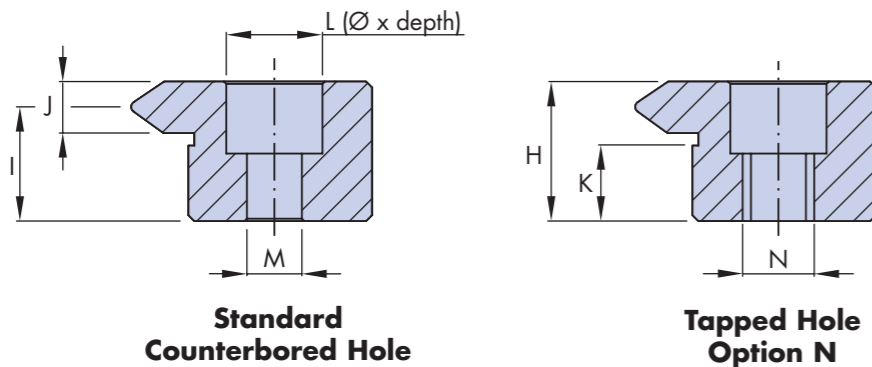
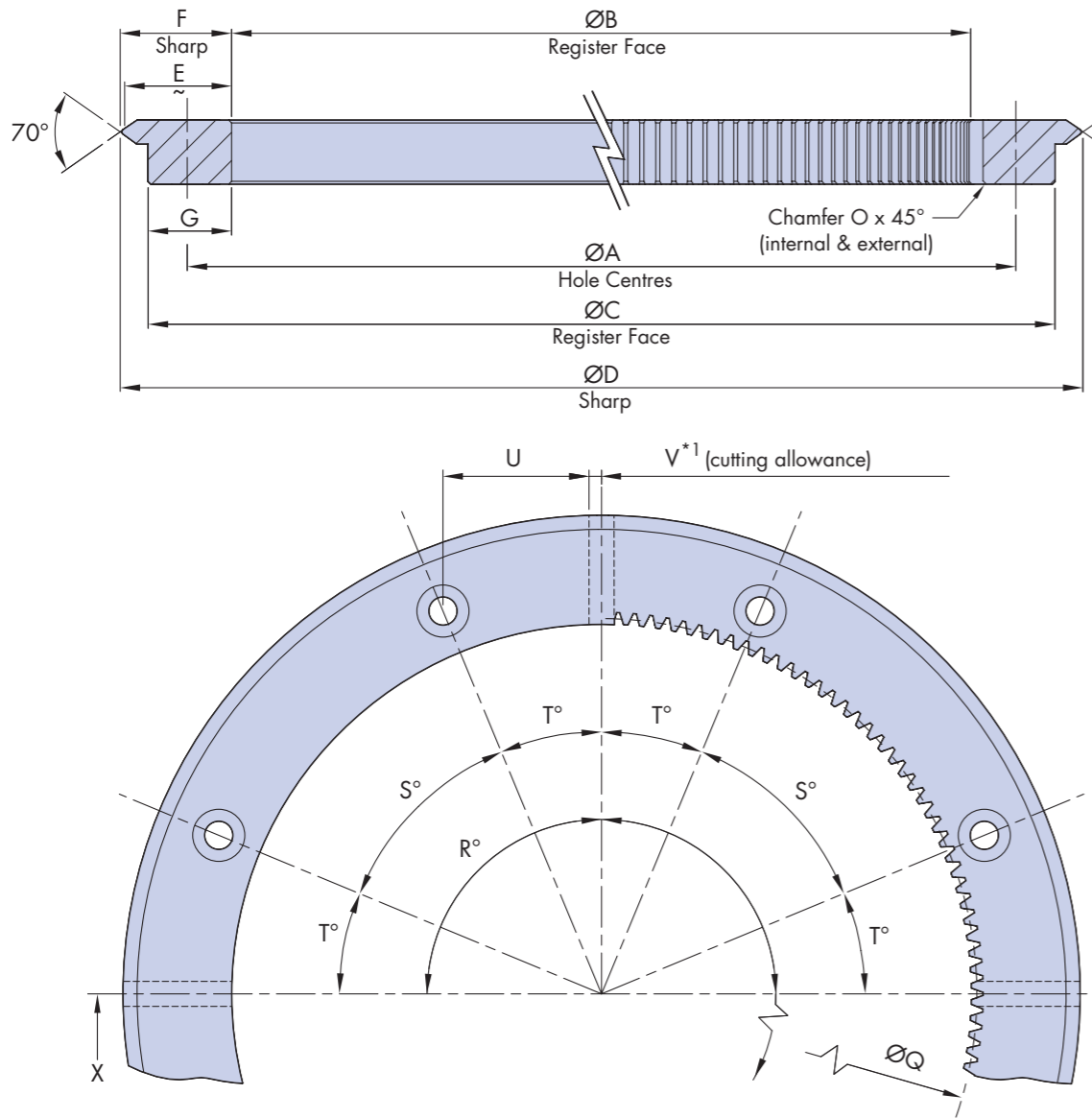

**Notes:**

- Standard ring segments will be slightly less than 90° and 180° because of the cutting allowance. Full 90° and 180° segments can be supplied to customer's special order.

# External Single Edge Ring Slides & Segments

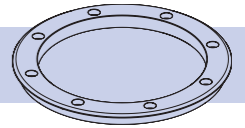

HepcoMotion ring segments are cut from complete 360° ring slides and held in stock in nominal 90° and 180° segments. Any length segment can be cut to customer's special order and additional holes drilled as required. Although suitable for most applications, slight out of roundness and flatness may be experienced with slide rings and segments in their free unmounted condition. This may be overcome by installing against a register and bolting to a flat surface. True shape rings and segments are available on request. Please visit [www.HepcoMotion.com/PRT2datauk](http://www.HepcoMotion.com/PRT2datauk) and select datasheet No. 9 True Shape Rings & Segments. Larger diameter single edge ring slides are available in the HDRT range for which there is a separate catalogue 61.

Part Number	For use with bearing (Ø)	A ±0.2	B (JS6) Register Ø	C Register Ø	D	E ~	F	G	H	I ±0.025	J	K	L	M	DIN912 (not supplied)
REV 156	... J18 ...	137.6	124.6 ±0.013	148.6 ±0.037	156.97	15.8	16.18	12	10	8	4.2	3.8	8 x 4.2	5.0	M4
REV 223	... J18 ...	204.8	191.8 ±0.015	215.8 ±0.037	224.17	15.8	16.18	12	10	8	4.2	3.8	8 x 4.2	5.0	M4
RES 184	... J25 ...	159	142 ±0.013	174 ±0.039	184.74	20.8	21.37	16	12.25	10	4.5	5.75	10 x 5.2	5.5	M5
RES 280	... J25 ...	255	238 ±0.015	270 ±0.041	280.74	20.8	21.37	16	12.25	10	4.5	5.75	10 x 5.2	5.5	M5
RES 376	... J25 ...	351	334 ±0.018	366 ±0.044	376.74	20.8	21.37	16	12.25	10	4.5	5.75	10 x 5.2	5.5	M5
REM 505	... J34 ...	468.5	447.5 ±0.020	487.5 ±0.046	506.24	28.8	29.37	20	15.5	12.5	6	7.0	11 x 6.2	6.8	M6
REM 655	... J34 ...	618.5	597.5 ±0.022	637.5 ±0.048	656.24	28.8	29.37	20	15.5	12.5	6	7.0	11 x 6.2	6.8	M6
REL 874	... J54 ...	820	788 ±0.025	848 ±0.051	874.74	42.8	43.37	30	24	19.5	9	12	18 x 10.3	11	M10

N	O	Internal Gear			Stock Segments <sup>1</sup>			Number of holes (R=360°)	Holes within ±0.2 of true position		U	V	kg- (R=360°)	Part Number
		Q	MOD	No of teeth (R=360°)	R°		S°		T°					
M6	0.4	126	0.7	180	-	-	360	8	45	22.5	25.3	1	0.42	REV 156
M6	0.4	193.2	0.7	276	-	-	360	8	45	22.5	38.2	1	0.63	REV 223
M8	0.5	144	1	144	90	180	360	8	45	22.5	29.4	1	0.78	RES 184
M8	0.5	240	1	240	90	180	360	8	45	22.5	47.8	1	1.27	RES 280
M8	0.5	336	1	336	90	180	360	12	30	15	44.4	1	1.75	RES 376
M8	0.5	450	1.25	360	90	180	360	12	30	15	58.6	2	3.93	REM 505
M8	0.5	600	1.25	480	90	180	360	16	22.5	11.25	58.3	2	5.18	REM 655
M16	1.0	792	2	396	-	-	360	16	22.5	11.25	78	2	15.64	REL 874

**Ordering details:**

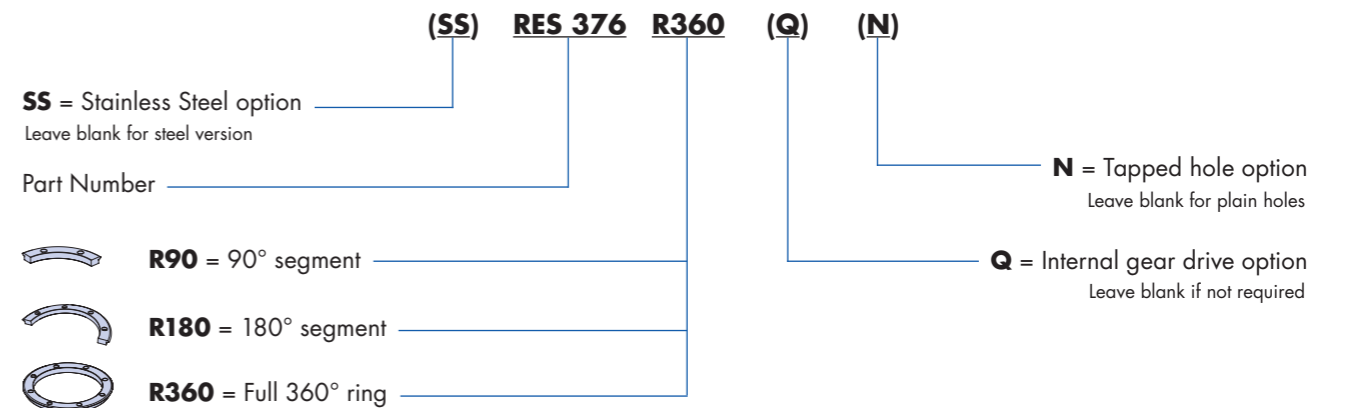



HepcoMotion single edge ring slides are manufactured from high quality steel, zone hardened on the V edge and precision ground all over. Datum register faces are provided both internally and externally for ease of location. Gear drive options are available with teeth machined into the external register face. The number of teeth is divisible by 4 and 12 in order to provide maximum choice of pinion size for exact ratio requirements. Customers may also choose the tapped hole option 'N' which enables the ring slide to be bolted from below. Stainless steel ring slides and segments are available for customers requiring corrosion resistance.

Section X-X

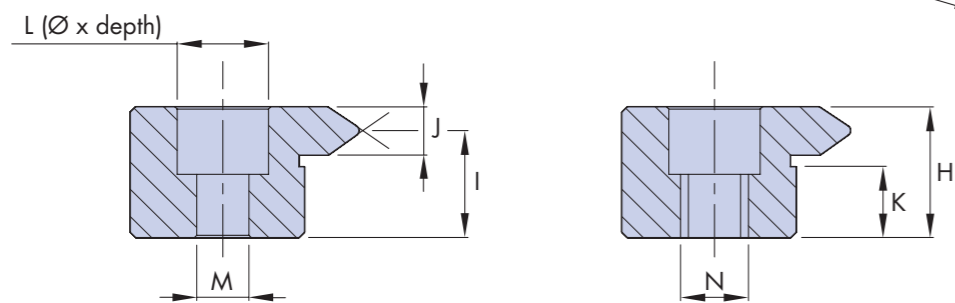
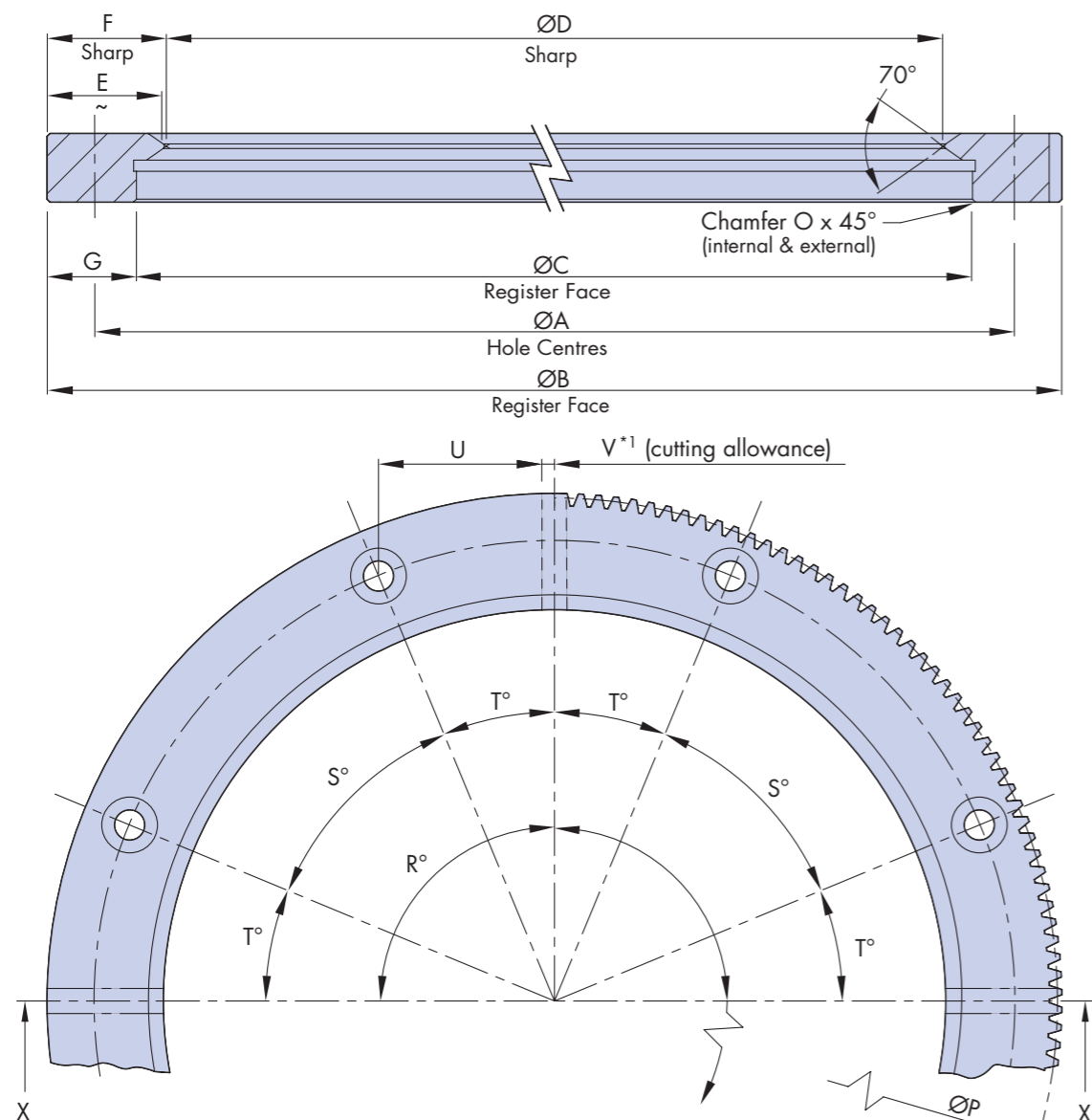

Standard Counterbored Hole

Tapped Hole Option N

- Notes:**
- Standard ring segments will be slightly less than 90° and 180° because of the cutting allowance. Full 90° and 180° segments can be supplied to customer's special order.

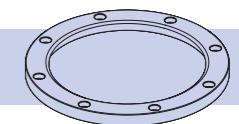

HepcoMotion single edge ring segments are cut from complete 360° ring slides and held in stock in nominal 90° and 180° segments. Any length segment can be cut to customer's special order and additional holes drilled as required. Although suitable for most applications, slight out of roundness and flatness may be experienced with slide rings and segments in their free unmounted condition. This may be overcome by installing against a register and bolting to a flat surface, True shape rings and segments are available on request. Please visit [www.HepcoMotion.com/PRT2datauk](http://www.HepcoMotion.com/PRT2datauk) and select datasheet No. 9 True Shape Rings & Segments. Larger diameter single edge ring slides are available in the HDRT range for which there is a separate catalogue 61.

Part Number	For use with bearing (Ø)	A ±0.2	B (J56) Register Ø	C Register Ø	D	E ~	F	G	H	I ±0.025	J	K	L	M	DIN912 (not supplied)
RIV 161	... J18 ...	148	161 ±0.013	137 ±0.037	128.63	15.8	16.18	12	10	8	4.2	3.8	8 x 4.2	5.0	M4
RIV 228	... J18 ...	215.2	228.2 ±0.015	204.2 ±0.037	195.83	15.8	16.18	12	10	8	4.2	3.8	8 x 4.2	5.0	M4
RIS 182	... J25 ...	165	182 ±0.015	150 ±0.039	139.26	20.8	21.37	16	12.25	10	4.5	5.75	10 x 5.2	5.5	M5
RIS 278	... J25 ...	261	278 ±0.016	246 ±0.041	235.26	20.8	21.37	16	12.25	10	4.5	5.75	10 x 5.2	5.5	M5
RIS 374	... J25 ...	357	374 ±0.018	342 ±0.044	331.26	20.8	21.37	16	12.25	10	4.5	5.75	10 x 5.2	5.5	M5
RIM 482	... J34 ...	461.5	482.5 ±0.020	442.5 ±0.046	423.76	28.8	29.37	20	15.5	12.5	6	7	11 x 6.2	6.8	M6
RIM 627	... J34 ...	606.5	627.5 ±0.022	587.5 ±0.048	568.76	28.8	29.37	20	15.5	12.5	6	7	11 x 6.2	6.8	M6
RIL 820	... J54 ...	788	820 ±0.028	760 ±0.051	733.26	42.8	43.37	30	24	19.5	9	12	18 x 10.3	11	M10

N	O	External Gear			Stock Segments*1			Number of holes (R=360°)	Holes within ±0.2 of true position		U	V	kg (R=360°)	Part Number
		P	MOD	No of teeth (R=360°)	R°		S°		T°					
M6	0.4	159.6	0.7	228	-	-	360	8	45	22.5	27.3	1	0.42	RIV 161
M6	0.4	226.8	0.7	324	-	-	360	8	45	22.5	40.2	1	0.63	RIV 228
M8	0.5	180	1	180	90	180	360	8	45	22.5	30.6	1	0.78	RIS 182
M8	0.5	276	1	276	90	180	360	8	45	22.5	48.9	1	1.27	RIS 278
M8	0.5	372	1	372	90	180	360	12	30	15	45.2	1	1.75	RIS 374
M8	0.5	480	1.25	384	90	180	360	12	30	15	57.7	2	3.93	RIM 482
M8	0.5	625	1.25	500	90	180	360	16	22.5	11.25	57.2	2	5.18	RIM 627
M16	1.0	816	2	408	-	-	360	16	22.5	11.25	74.9	2	15.64	RIL 820

Ordering details:

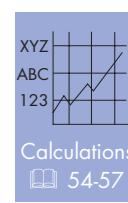
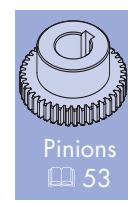
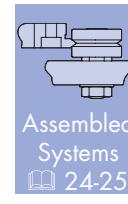
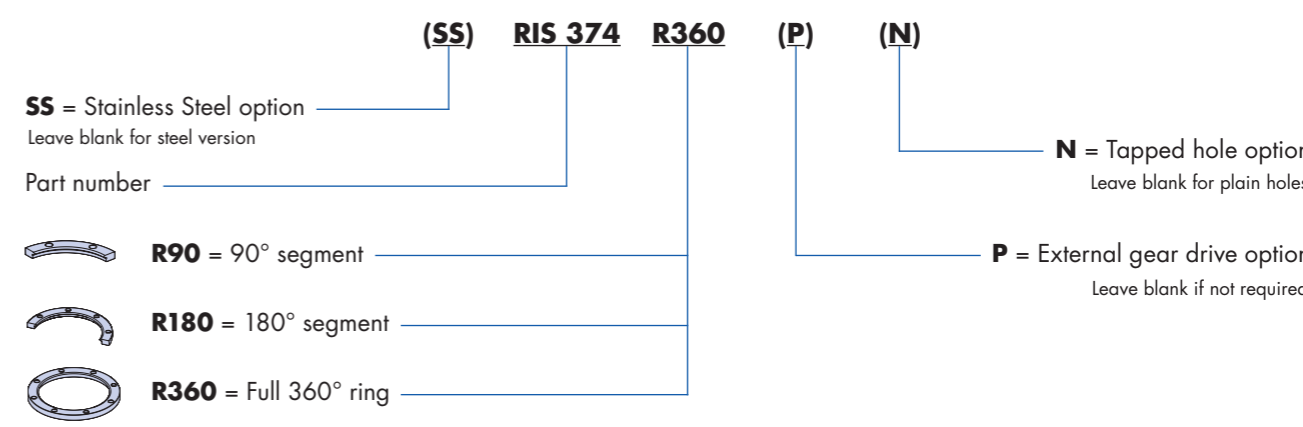

## Ring Discs

HepcoMotion Ring Discs are ideally suited for turntable applications where a precision platform is required for the mounting of components. Ring discs are made from high quality steel, hardened on the V edge and precision ground all over\*1. An external datum register is provided and a gear drive option is available in which the number of teeth is divisible by 4 and 12 in order to provide maximum choice of pinion size for exact ratio requirements.

All key dimensions are the same as for the corresponding size of Double Edge Ring Slide [27](#).

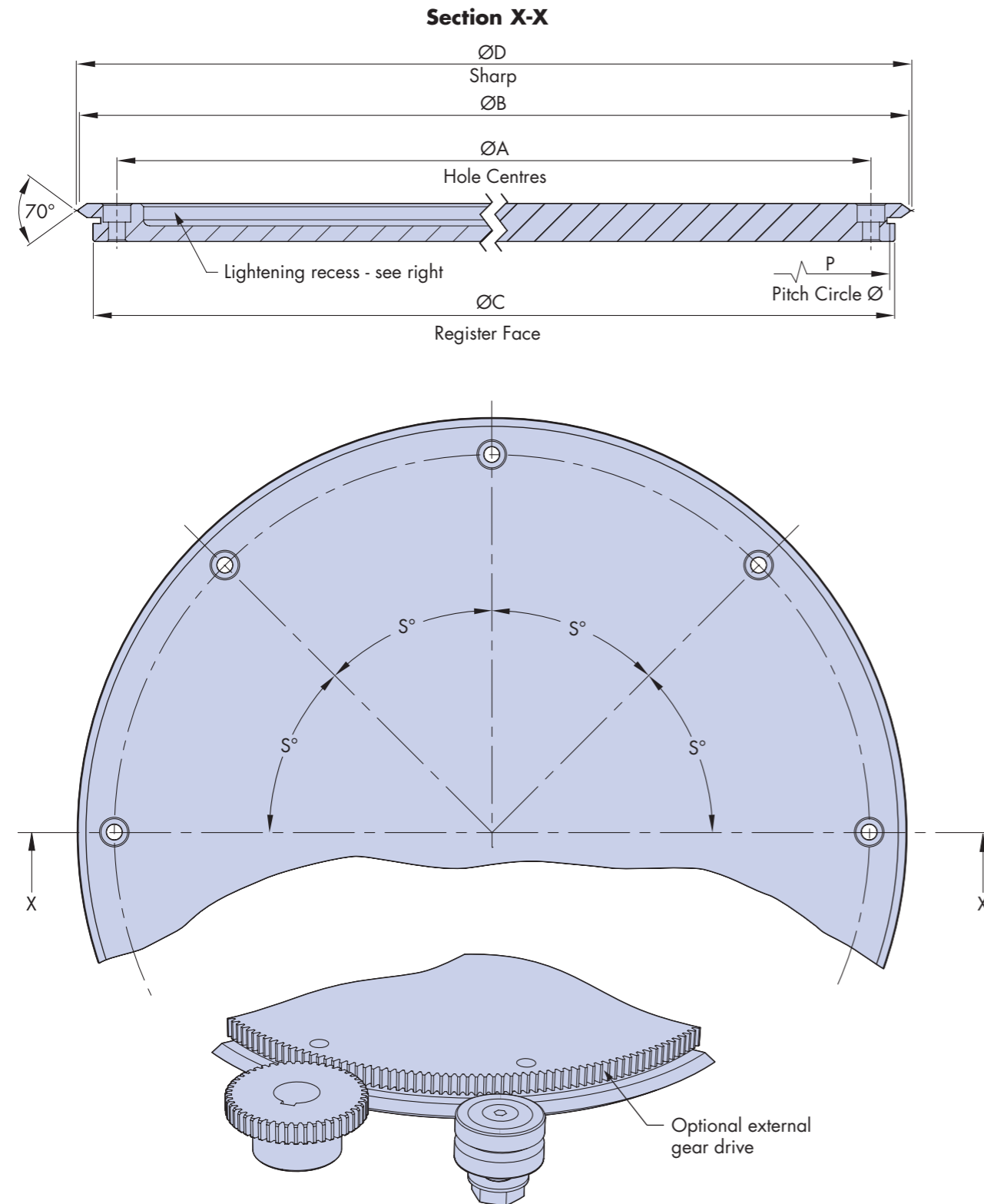

### Notes:

1. The internal faces of the lightening recess in the lightweight version are not ground. On stainless steel ring discs, these surfaces are polished.

## Ring Discs

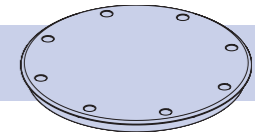

For applications where weight is an issue, a lightweight version (option 'L') is available. Stainless steel ring discs are also available, as is the tapped hole option 'N'.

Ring discs can be made to customer's specification, on request. Variations include other diameters, different thicknesses, special holes, registers or other mounting features, and alternative patterns of lightening recess.

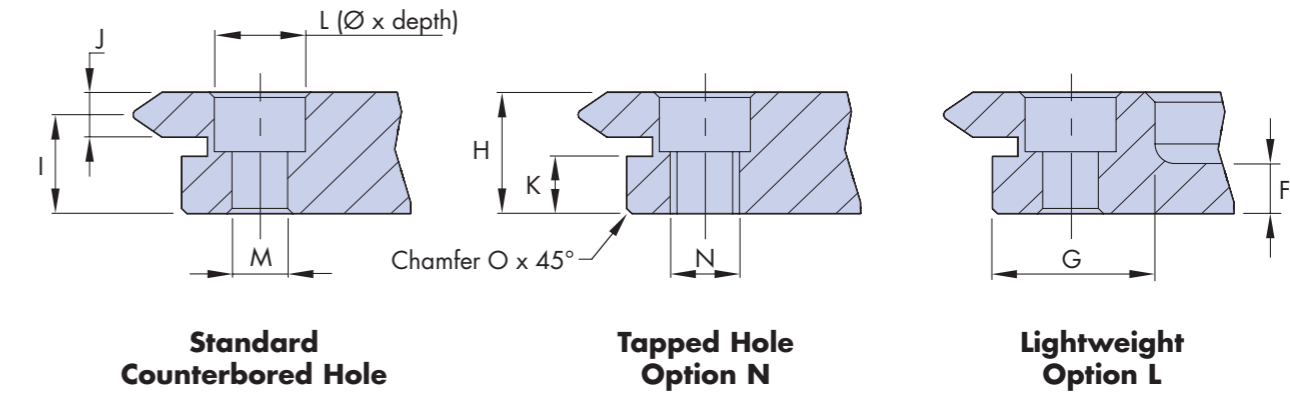

Part Number	For use with bearing (Ø)	A ±0.2	B	C Register Ø	D	F	G	H	I ±0.025	J	K	L
<b>RD25 159</b>	... J25 ...	159	184	174.4 ±0.039	184.74	5	15.4	12.25	10.0	4.5	5.75	9 x 6
<b>RD25 255</b>	... J25 ...	255	280	270.4 ±0.041	280.74	5	15.4	12.25	10.0	4.5	5.75	9 x 6
<b>RD25 351</b>	... J25 ...	351	376	366.4 ±0.044	376.74	5	15.4	12.25	10.0	4.5	5.75	9 x 6
<b>RD44 468</b>	... J34 ...	468	512	494 ±0.046	512.74	6	26	15.5	12.5	6	7	11 x 7

M	DIN912 (not supplied)	N	O	External Gear			Number of Holes	Holes within ±0.2 of true position S°	kg~		Part Number
				P	MOD	No of teeth			Standard	Lightweight	
5.5	M5	M8	0.5	172.8	0.8	216	8	45	2.3	1.4	<b>RD25 159</b>
5.5	M5	M8	0.5	268.8	0.8	336	8	45	5.5	3.0	<b>RD25 255</b>
5.5	M5	M8	0.5	364.8	0.8	456	12	30	10.2	5.2	<b>RD25 351</b>
6.8	M6	M8	0.5	492	1	492	12	30	23.6	12.2	<b>RD44 468</b>

### Ordering details:

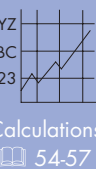
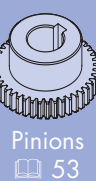
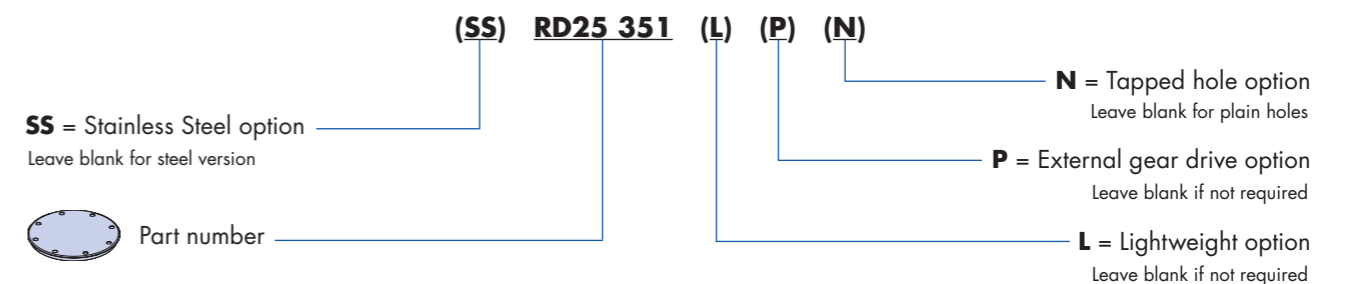

# Bearings

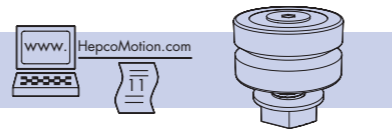

HepcoMotion PRT2 bearings are available in five sizes to suit the five ring slide sections. Bearings can be used with more than one ring size: for details, please visit [www.HepcoMotion.com/PRT2datauk](http://www.HepcoMotion.com/PRT2datauk) and select datasheet No. 11 PRT2 mix and match. The following bearing formats and fixing methods cater for most design requirements:

**Twin Bearing type** has the smoothest running quality, is easiest to adjust and offers some compliance to accommodate misalignment. It has two deep groove ball bearings on a single stud, and is the usual choice for many systems.

**Double Row Bearing type (DR)** incorporates a one-piece outer ring with two ball tracks. It offers more load capacity, life and stiffness, and copes better with debris. Dimensions are identical to the twin bearings type. DR bearings are more demanding of installation tolerances and it is recommended that they are specified with the CHK option\*4.

**Nitrile Sealed option (NS)** available for both bearing formats, provides better sealing against water or debris than the metal shielded type. A small increase in friction may result.

See 20 for the bearing and lubrication selector.

## Through Fixing Type (RSJ/RLJ)

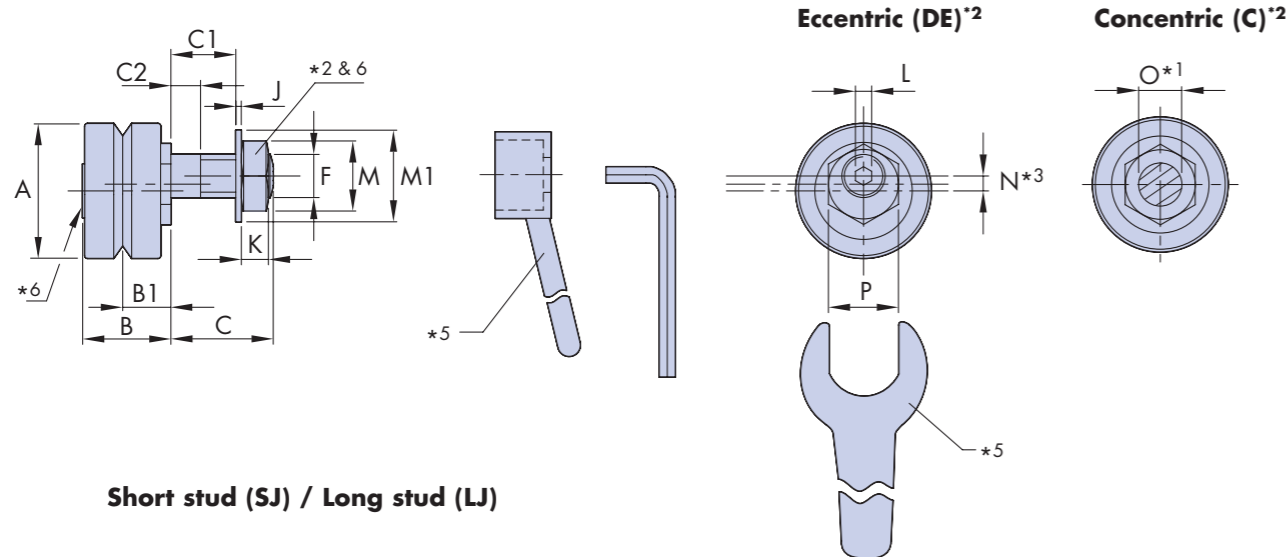

# Bearings

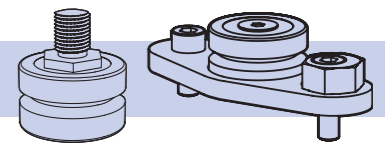

**Through Hole Fixing** type is available in two stud lengths covering most thicknesses of mounting plate, the short version being used in HepcoMotion carriages. Both are available in **Concentric (C)** which provides a datum for the system, and **Eccentric (DE)** to provide enough adjustment to permit disengagement of a carriage or ring encircled by bearings 58.

All bearings are available in a **Controlled Height version (CHK)** which minimises variation in the B1 dimension\*4. This is desirable in high precision applications and is recommended whenever Double Row Bearings are used.

**Blind Hole Fixing type (RBHJ)** allows mounting into a solid machine base where through mounting holes are not possible, or where the thickness of the mounting plate is too great. The Blind Hole Fixing type is also useful where adjustment from the front is preferred or where access to the opposite side of the mounting hole is restricted. They are available in **Concentric (C)** which are fixed, or **Eccentric (E)** which are adjustable.

All bearings are greased for life internally. Customers are strongly advised to provide lubrication to the interface between bearings and ring slide by specifying HepcoMotion Lubricators 37 or Bleed Lubrication system 52. Lubrication greatly increases load capacity and life.

## Blind Hole Fixing Type (RBHJ)

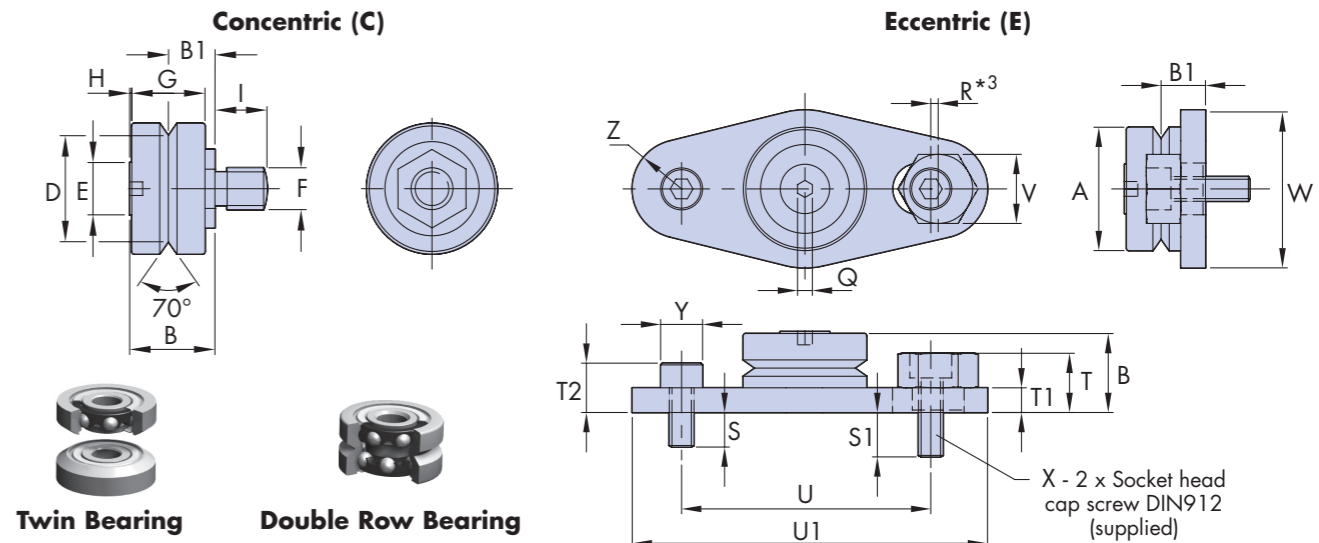

Part Number	For use with				A	B	B1*4	C		C1		C2		D ±0.025	E	F Metric Fine	G	H	I	J	K	L	M	M1	N*3	O*1 +0.0 -0.03	P
	R12	RD25	RES, RIS	TNMS				RSJ	RLJ	RSJ	RLJ	RSJ	RLJ														
... J13 ...	R12	-	-	TNMS	12.7	10.1	5.47	5.8	9.5	3	6.7	2.2	2.4	9.51	5	M4 x 0.5	8	0.5	5.8	0.8	2.2	-	7	9	1.9	4	7
... J18 ...	R20	-	REV, RIV	TNV	18	12.4	6.75	7.4	14	3.4	10	2.4	2.5	14.00	7	M6 x 0.75	10	0.6	7.4	0.8	3.2	2.5	10	13	2.6	6	11
... J25 ...	R25	RD25	RES, RIS	TNS	25	16.6	9	9.8	19	3.8	13	2.2	4.9	20.27	10	M8 x 1	14	0.5	9.8	1	5	3	13	17	2.75	8	13
... J34 ...	R44	RD44	REM, RIM	TNM	34	21.3	11.5	13.8	22	6.6	14.8	5.2	5.9	27.13	12	M10 x 1.25	18	0.7	13.8	1.25	6	4	17	21	3.6	10	15
... J54 ...	R76	-	REL, RIL	TNL	54	34.7	19	17.8	30	8.2	20.4	5.7	7.9	41.76	25	M14 x 1.5	28	1.6	17.8	1.6	8	6	22	28	5.5	14	27

Q	R*3	S	S1	T	T1	T2	U ±0.1	U1	V	W	X	Y	Z	Adjusting Wrench *5	Socket Tool *5	Options Available					Part Number				
																RSJ..C/E	RLJ..C/E	RBHJ..C	RBHJ..E	- Metal shields		NS*7 Nitrile Seals	- Twin Bearing	DR Double Row	CHK Controlled Height
1.5	1.0	6.25	6.6	8.5	3.75	6.75	30	47.5	8	20	M3	5.5	8	AT13	-	8	8	7	27	x	✓	✓	x	✓	... J13 ...
2	1.2	8	10.5	10	4	8	38	54	11	24.5	M4	7	7	AT18	RT6	19	20	18	45	x	✓	✓	✓	✓	... J18 ...
3	1.5	7	9	12	5	10	50	72	14	32	M5	8.5	10	AT25	RT8	48	51	43	105	✓	✓	✓	✓	✓	... J25 ...
4	2.0	9.5	8.5	17.5	6.5	12.5	60	90.5	17	42	M6	10	14	AT34	RT10	115	120	105	235	✓	✓	✓	✓	✓	... J34 ...
8	3.0	14.5	16.4	23.5	10.5	18.5	89.5	133	25	62	M8	13	20	AT54	RT14	415	425	390	800	✓	✓	✓	✓	✓	... J54 ...

### Notes:

- It is recommended that holes to suit bearing mounting studs should be reamed to tolerance F6 for a sliding fit.
- Nuts and washers are supplied with both concentric and eccentric RSJ/RLJ type bearings.
- 'N' is the eccentric offset due to the double eccentric design (2 x N = total stroke). R dimension is both the eccentric offset of the adjusting nut and total stroke at the bearing centreline.
- Controlled height (CHK) bearings are selected in ±0.010mm bands in respect of the B1 dimension. They are supplied in sets of up to 50 parts as standard, with larger sets on request.
- For adjusting tool part numbers see table. For adjustment procedure and fixing nut tightening torques see 58.
- Fasteners for the through fixing type bearings are black on the concentric version and bright zinc plated on the eccentric version for identification purposes, except stainless steel type.
- Stainless steel bearings are only available nitrile sealed.

### Ordering details:

**(SS)** **RSJ** **25** **C** **(DR)** **(NS)** **(CHK)**  
**SS** = Stainless steel option\*7 Leave blank for steel version  
**CHK** = Controlled height\*4 Leave blank if not required  
**NS** = Nitrile sealed option\*7 Leave blank for metal shields  
 Fixing type: **RSJ** = Short stud  
                   **RLJ** = Long stud  
                   **RBHJ** = Blind hole fixing  
 Bearing diameter options are 13, 18, 25, 34 & 54  
 Bearing type: **DR** = Double row bearing Leave blank for twin bearing  
 Journal type: **C** = Concentric (fixed)  
                   **E** = Eccentric (adjustable, RBHJ only)  
                   **DE** = Eccentric (adjustable RSJ/RLJ only)



Assembled Systems 22-25

Ring slides 26-33

Lubricators 37

FCC carriage 38-39

BCP carriage 47

Track system 40-41

Calculations 54-57

## Floating Bearings

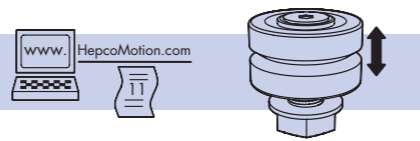

HepcoMotion Floating Bearings incorporate caged needle rollers and are designed to provide axial movement (float) of the V position. This is especially useful where two rings or track systems are mounted apart, see application example 14.

The float compensates for parallelism tolerances between the opposing V's, eliminating additional loading and maintaining consistent running quality. Three sizes are available, each to correspond with one ring slide section, but they can be used with other sections. Please visit [www.HepcoMotion.com/PRT2datauk](http://www.HepcoMotion.com/PRT2datauk) and select datasheet No. 11 PRT2 mix and match.

Two stud lengths are available covering most thicknesses of mounting plate, the short version being compatible with HepcoMotion carriage plates. Both versions are available in **Concentric (C)** which provides a datum (in radial direction) for the system, and **Eccentric (DE)** which provides sufficient adjustment to allow disengagement of a carriage or ring encircled by bearings 58.

All bearings are greased for life internally. Customers are strongly advised to provide lubrication to the interface between bearings and ring slide by specifying HepcoMotion Lubricators 37 or bleed lubrication system 52. Lubrication greatly increases load capacity and life.

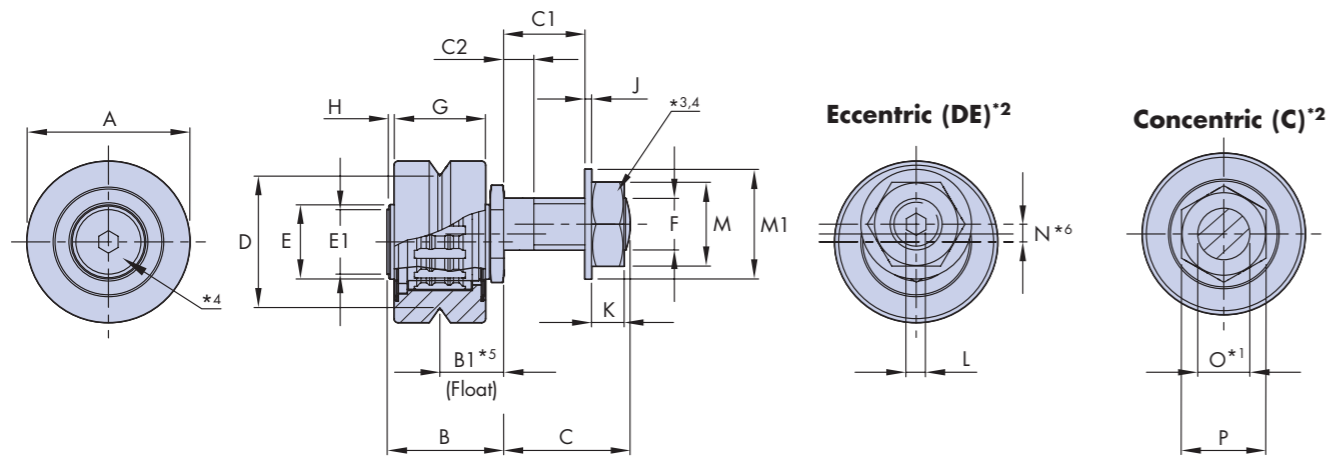

### Short stud (RSFJ) / Long stud (RLFJ)

Part Number	For use with				A	B	B1*5		C	C1		C2		D ±0.025	E	E1	F Metric Fine	G	H ~	
	R25	RD25	RES, RIS	TNS			Min	Max		RSFJ	RLFJ	RSFJ	RLFJ							RSFJ
... FJ25 ...	R25	RD25	RES, RIS	TNS	25	18.1	9	10.5	9.8	19	3.8	13	3.4	4.9	20.27	11.5	10	M8 x 1	14	0.8
... FJ34 ...	R44	RD44	REM, RIM	TNM	34	23.2	11.5	13.5	13.8	22	6.6	14.8	5.2	5.9	27.13	16	12	M10 x 1.25	18	1
... FJ54 ...	R76	-	REL, RIL	TNL	54	37.2	19	21.6	17.8	30	8.2	20.4	5.7	7.9	41.76	28	25	M14 x 1.5	28	1.3

J	K	L	M	M1	N*6	O*1 ±0 -0.03	P	Adjusting Wrench *3	Socket Tool *3	g~	Max Working Load Capacity (N)	Bearing Static (Co) and Dynamic (C) Radial Load Capacities (N)		Part Number	
												Co	C		
1	5	3	13	17	2.75	8	13	AT25	RT8	58	60	1500	6100	4900	... FJ25 ...
1.25	6	4	17	21	3.6	10	15	AT34	RT10	130	135	3000	12500	11500	... FJ34 ...
1.6	8	6	22	28	5.5	14	27	AT54	RT14	495	505	5000	28900	21500	... FJ54 ...

### Notes:

- It is recommended that holes to suit bearing mounting studs should be reamed to tolerance F6 for a sliding fit.
- Nuts and washers are supplied with both concentric and eccentric RSFJ/RLFJ type bearings.
- For adjustment procedure and bearing fixing nut tightening torques see 58.
- Fasteners are black on the concentric version and bright zinc plated on the eccentric version for identification purposes.
- 'B1' dimension is the min/max axial movement of the V centre.
- 'N' is the eccentric offset due to the double eccentric design (2 x N = total stroke).

### Ordering details:

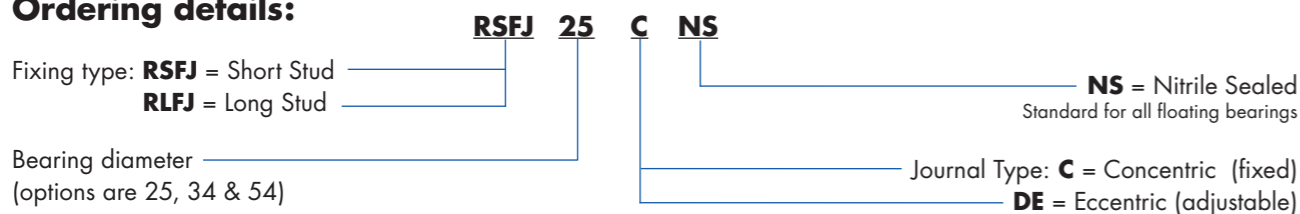

## Lubricators

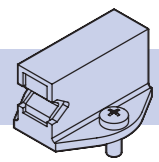

HepcoMotion lubricators are made from impact resistant plastic and house a sprung oil impregnated felt wiper designed to apply a constant film of oil to the working surfaces of the ring slide without imposing undue friction. The application of oil significantly increases the load and life of the system. Either type of lubricator can be used with individual ring slides, segments and ring discs. The compact type can be used with Hepco fixed centre carriage plates. Customers may also consider using the HepcoMotion bleed lubrication facility suitable for track systems 52.

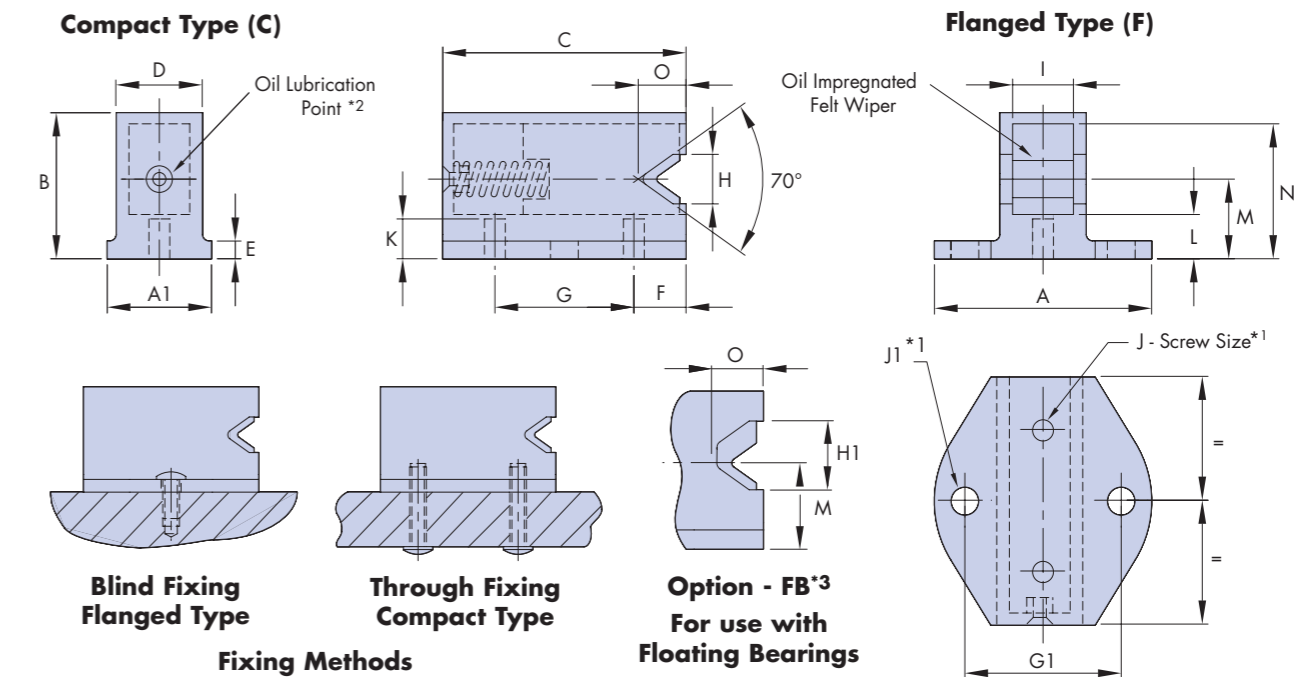

Part Number	For Use with				Type F	Type C	B	C	D	E	F	G ±0.1	G1 ±0.1
	R12	R20	REV, RIV	TNMS 12	A	A1							
<b>LB 12</b>	R12	-	-	TNMS 12	17	7	10	13	5.2	2	3	6.5	12
<b>LB 20</b>	R20	-	REV, RIV	TNV 20	19	8	12	22.5	6.5	2	4.75	13	13
<b>LB 25</b>	R25	RD25	RES, RIS	TNS 25, TNSE	25	12	16.5	28	9.9	2	6	16	18
<b>LB 44</b>	R44	RD44	REM, RIM	TNM 44, TNME	34	17	20	38	15	2.4	8	22	25
<b>LB 76</b>	R76	-	REL, RIL	TNL 76	50	25	33.5	57	22.7	4.5	12	33	38

H	H1	I	J Ø x Length	J1		K	L	M	N	O	g~	Part Number
				Screw Size	Hole Ø							
3.1	-	3	2.5 x 5	M2.5 x 6	2.7	2.5	3	5.46	9	2.2	2	<b>LB 12</b>
7.2	-	4	2.5 x 10	M2.5 x 6	2.7	2.5	3.5	6.75	10.75	4.5	3	<b>LB 20</b>
5.5	7.1	7	3 x 10	M3 x 8	3.2	4.5	5	9	15.25	5.5	6	<b>LB 25</b>
7	9	11	3 x 16	M4 x 10	4.2	5.5	6.25	11.5	18.25	8	16	<b>LB 44</b>
10	12.6	18	3.5 x 22	M5 x 12	5.2	9	10	19	31.5	11.5	44	<b>LB 76</b>

### Notes:

- 2 machine screws with cross-recessed pan heads to DIN7985A are supplied for fixing the flanged type lubricator (see J1 in table). Additionally, 2 self tapping screws for plastic with PT thread form and cross-recessed pan heads are supplied for the compact type lubricator (see J in table).
- Lubrication interval depends on length of stroke, duty and environmental factors. Replenish lubricant as necessary using a 68 viscosity EP mineral oil.
- Size 25, 44 & 76 lubricators are available with increased clearance "H1" to accommodate the "V float" of the floating bearings 36.

### Ordering details:

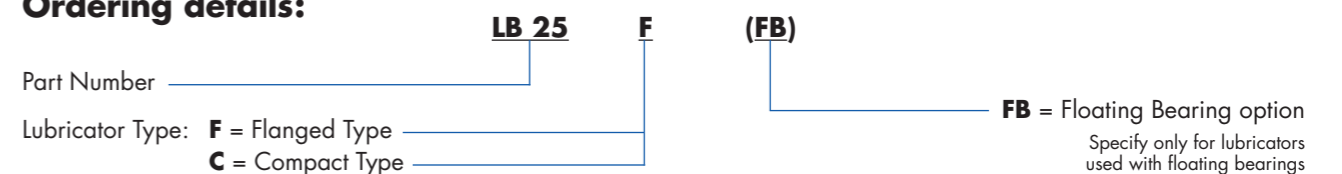

# Fixed Centre Carriage



The HepcoMotion Fixed Centre Carriage is designed for use with track systems with unidirectional bends of a common radii 40 and for use with double edge ring slides and segments 26-27. The unique geometry enables carriages on a track system to travel from straight to curve with negligible play in the transition zone. Such play as may develop is not detrimental to the performance of the system\*1.

Carriages are available with twin or double row (DR) bearings 34-35, and with floating bearings 36. Carriages with twin bearings have the smoothest running quality and have some compliance to accommodate misalignment. Carriages with DR bearings have better load capacity and stiffness. Due to the rigidity of DR bearings, carriages with this option are supplied as Controlled Height (CHK)\*5 as standard.

The corrosion resistant version has stainless steel bearings and fasteners, and a high performance USDA approved surface treatment to the aluminium carriage plate in place of the standard anodised finish.

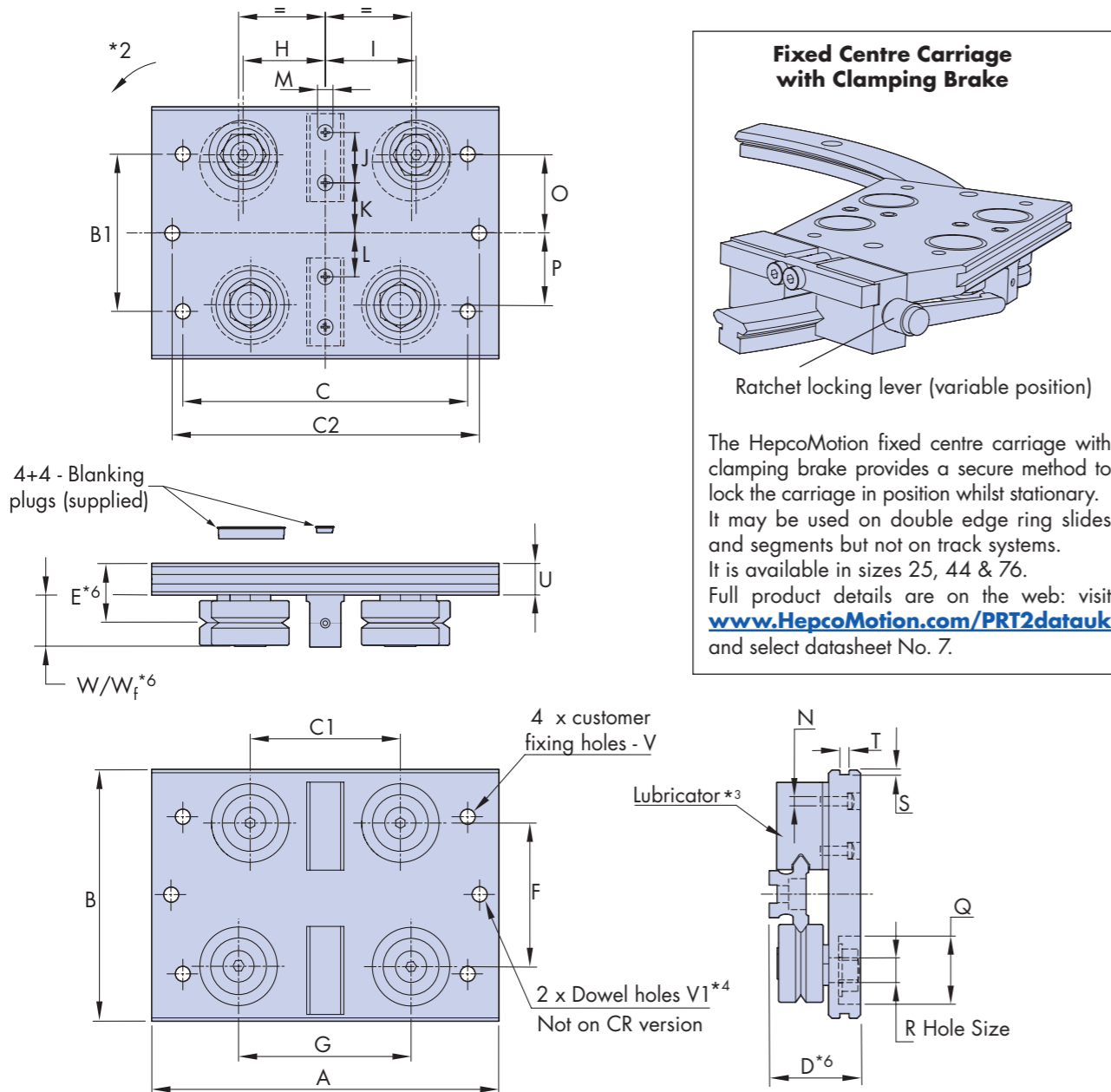

**Fixed Centre Carriage with Clamping Brake**

Ratchet locking lever (variable position)

The HepcoMotion fixed centre carriage with clamping brake provides a secure method to lock the carriage in position whilst stationary. It may be used on double edge ring slides and segments but not on track systems. It is available in sizes 25, 44 & 76. Full product details are on the web: visit [www.HepcoMotion.com/PRT2datauk](http://www.HepcoMotion.com/PRT2datauk) and select datasheet No. 7.

### Notes:

- Fixed centre carriages will experience a reduction in preload or a slight clearance as they pass between the curves and straights on a track system, but this is rarely an issue. This clearance is detailed on 57. Please note the FCC25 159 has a larger than normal clearance. Bogie carriages 47 are not subject to clearance.
- Offset holes in carriage for eccentric bearings necessitate adjustment rotation in the direction shown.
- It is recommended that carriages are fitted with lubricators. The quantity of lubricators may be reduced in systems with many carriages or where the bleed lubrication facility is used 52.
- Dowel holes V1 define the centre and may be used for location purposes. They are not included as standard on the corrosion resistant version, but are available on special request.
- CHK controlled height carriages use CHK bearings 35 and are supplied in sets, matched by their E dimension. It is recommended to specify CHK for precision applications or where consistent carriage heights are important. CHK is standard for carriages with DR bearings.
- The W dimension is greater for carriages with floating bearings - see Wf in the table. Dimensions D and E will change for carriages with floating bearings. The amount of float is indicated by dimension B1 36.

# Fixed Centre Carriage

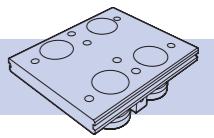

Part Number	For Use with			A	B	B1	C	C1	C2 ±0.01	D*6	E*6	F	G	H	I	J	K
<b>FCC12 93</b>	R12 93 R360/R180/R90	TR12 93		55	40	25	48	20	45	19	12.8	21.9	25.52	11.11	14.41	6.5	9.3
<b>FCC12 127</b>	R12 127 R360/R180/R90	TR12 127		55	40	25	48	20	45	19	12.8	21.9	23.84	10.27	13.56	6.5	8.8
<b>FCC20 143</b>	R20 143 R360/R180/R90	TR20 143		75	64	40	60	25	65	24.75	16.75	34.4	32.03	13.76	18.27	13	13
<b>FCC20 210</b>	R20 210 R360/R180/R90	TR20 210		80	64	40	65	28	70	24.75	16.75	34.4	33.06	14.28	18.87	13	12.7
<b>FCC25 159*1</b>	R25 159 R360/R180/R90	TR25 159		95	80	50	85	37	80	30.5	20.5	46	50.15	22.70	27.46	16	17.1
<b>FCC25 255</b>	R25 255 R360/R180/R90	TR25 255		100	80	50	80	36.5	85	30.5	20.5	46	43.86	19.55	24.31	16	15.9
<b>FCC25 351</b>	R25 351 R360/R180/R90	TR25 351		105	80	50	85	40	90	30.5	20.5	46	45.66	20.45	25.21	16	15.6
<b>FCC44 468</b>	R44 468 R360/R180/R90	TR44 468		145	116	75	120	65	125	38.5	26	71.9	75.95	35.22	40.73	22	25.8
<b>FCC44 612</b>	R44 612 R360/R180/R90	TR44 612		150	116	75	125	70	130	38.5	26	71.9	78.80	36.64	42.16	22	25.5
<b>FCC76 799</b>	R76 799 R360/R180/R90	TR76 799		190	185	100	160	90	165	58.5	39	118.5	104.56	49.13	55.44	33	43
<b>FCC76 1033</b>	R76 1033 R360/R180/R90	TR76 1033		210	185	100	180	110	185	58.5	39	118.5	123.48	58.59	64.90	33	43
<b>FCC76 1267</b>	R76 1267 R360/R180/R90	TR76 1267		250	185	100	205	130	225	58.5	39	118.5	142.82	68.26	74.57	33	44
<b>FCC76 1501</b>	R76 1501 R360/R180/R90	TR76 1501		270	185	100	225	150	245	58.5	39	118.5	162.38	78.04	84.35	33	44

L	M (Ø x depth)	NØ	O	P	Q (Ø x depth)	RØ (hole size) (F6)	S	T	U	V	V1Ø (K6)	W	Wf	g~	Part Number
7.8	4.5 x 4.5	2.7	11.89	10.94	12.5 x 4.8	4 +0.018 +0.010	1	3	7.34	M4	4 +0.002 -0.006	10.1	-	70	<b>FCC12 93</b>
7.8	4.5 x 4.5	2.7	11.89	10.94	12.5 x 4.8	4 +0.018 +0.010	1	3	7.34	M4	4 +0.002 -0.006	10.1	-	70	<b>FCC12 127</b>
12.3	4.5 x 2.5	2.7	18.49	17.19	15.8 x 7	6 +0.018 +0.010	1.5	4	10	M5	4 +0.002 -0.006	12.4	-	190	<b>FCC20 143</b>
12.3	4.5 x 2.5	2.7	18.49	17.19	15.8 x 7	6 +0.018 +0.010	1.5	4	10	M5	4 +0.002 -0.006	12.4	-	200	<b>FCC20 210</b>
14	5.3 x 4.5	3.2	24.38	23.01	22 x 8.4	8 +0.022 +0.013	2	5	11.5	M6	6 +0.002 -0.006	16.6	18.1	400	<b>FCC25 159*1</b>
14	5.3 x 4.5	3.2	24.38	23.01	22 x 8.4	8 +0.022 +0.013	2	5	11.5	M6	6 +0.002 -0.006	16.6	18.1	410	<b>FCC25 255</b>
14	5.3 x 4.5	3.2	24.38	23.01	22 x 8.4	8 +0.022 +0.013	2	5	11.5	M6	6 +0.002 -0.006	16.6	18.1	420	<b>FCC25 351</b>
23	5.3 x 4.5	3.2	38.25	35.94	25 x 8.7	10 +0.022 +0.013	2	6	14.5	M8	8 +0.002 -0.007	21.3	23.2	1080	<b>FCC44 468</b>
23	5.3 x 4.5	3.2	38.25	35.94	25 x 8.7	10 +0.022 +0.013	2	6	14.5	M8	8 +0.002 -0.007	21.3	23.2	1100	<b>FCC44 612</b>
40	8.0 x 6.0	3.8	63.76	59.25	32.1 x 13.5	14 +0.027 +0.016	4	8	20	M10	10 +0.002 -0.007	34.7	37.2	3460	<b>FCC76 799</b>
40	8.0 x 6.0	3.8	63.76	59.25	32.1 x 13.5	14 +0.027 +0.016	4	8	20	M10	10 +0.002 -0.007	34.7	37.2	3660	<b>FCC76 1033</b>
40	8.0 x 6.0	3.8	63.76	59.25	32.1 x 13.5	14 +0.027 +0.016	4	8	20	M10	10 +0.002 -0.007	34.7	37.2	4050	<b>FCC76 1267</b>
40	8.0 x 6.0	3.8	63.76	59.25	32.1 x 13.5	14 +0.027 +0.016	4	8	20	M10	10 +0.002 -0.007	34.7	37.2	4250	<b>FCC76 1501</b>

### Ordering details:

**(CR) FCC 44 612 (LB) (DR) (NS) (CHK)**

**CR\*4** = Corrosion resistant option  
Leave blank if not required

**LB\*3** = Lubricator option  
Leave blank if not required

**CHK\*5** = Controlled height option 35  
Standard with DR bearings  
Leave blank if not required for twin bearing version

**NS** = Nitrile sealed bearings fitted 34  
Leave blank for metal shields

Bearing type: **FJ** = Floating bearings 36  
**DR** = double row bearings 34  
Leave blank for twin bearings

Clamping Brake option available, please refer to PRT2 datasheet No.7

[www.HepcoMotion.com/PRT2datauk](http://www.HepcoMotion.com/PRT2datauk)



Assembled Systems 22-23

Ring slides 26-27

Bearings 34-36

Lubricator 37

BCP carriage 47

Track system 40-41

Calculations 54-57

HepcoMotion track systems provide a unique method of achieving an almost limitless variety of open or closed circuits by combining straight slides with curved slides. They can be used in any orientation, from horizontal to vertical. Some of the more common track configurations are illustrated on this, and the opposite page. Any number of carriages can be accommodated, either the fixed centre economy type or the bogie type which enables 'S' bends or bends of varying radii to be negotiated and which has a larger platform for mounting purposes. A unique jacking screw facility incorporated within the track system enables perfect alignment of straight slides to curved slides. Various drive possibilities exist some of which are illustrated 14-18. Lubrication of the system is achieved either by means of lubricators incorporated within the fixed centre carriages or by means of the HepcoMotion bleed lubrication facility 52 which injects lubricant direct to the V faces of the track. The relevant dimensions of individual track system slides are held on record to enable spares and replacements to be supplied. Track systems are also available in stainless steel for applications requiring greater corrosion resistance.

**Rectangular track system**

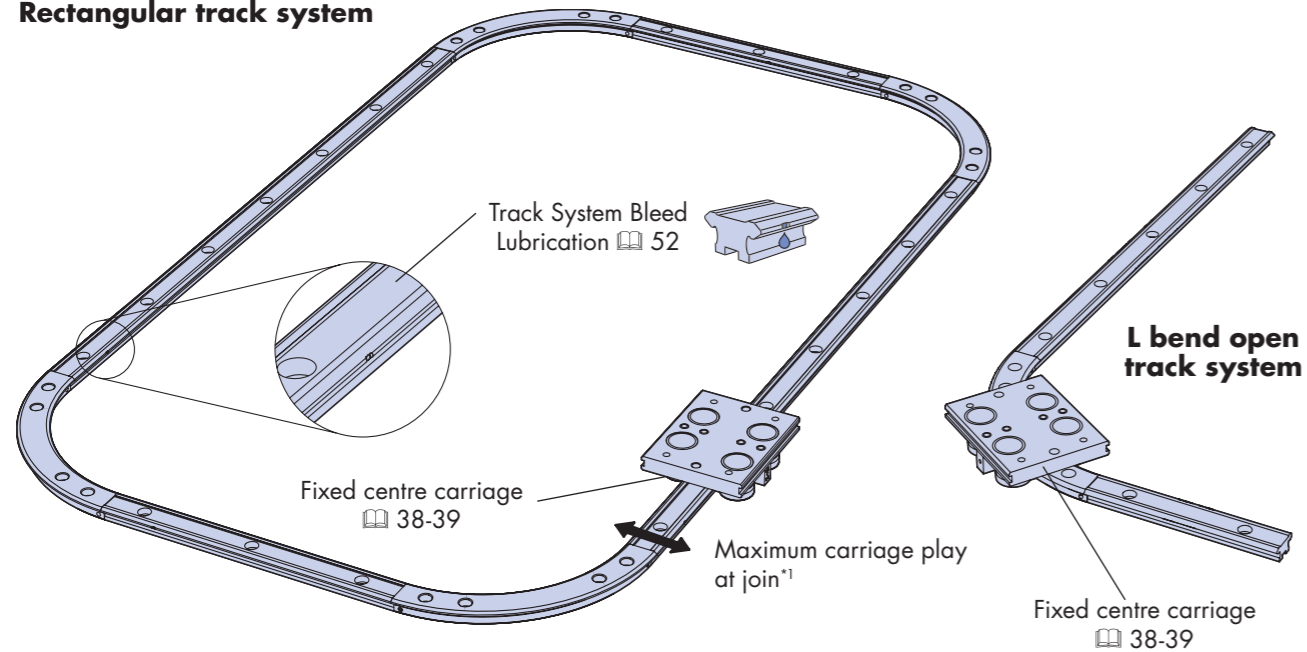

**Oval track system**

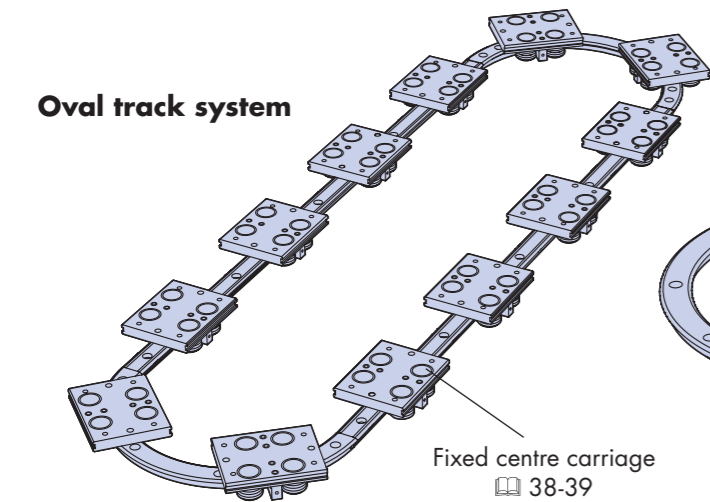

**Triangular track system**

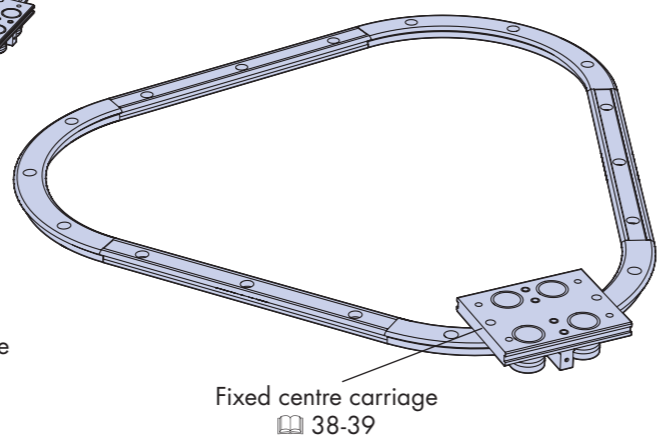

**Installation**

Installation requires manual drilling and setting. Track systems are also available in suitable grade to correspond with customers pre-drilled mounting holes. Please visit [www.HepcoMotion.com/PRT2datauk](http://www.HepcoMotion.com/PRT2datauk) and select datasheet No. 2 Installation details.

**Notes:**

1. With the fixed centre carriage, some slight play develops as each pair of opposing bearings traverse the join between straight and curve. This is rarely an issue in use. The maximum play acting in the direction of the arrows is given in the table on 57.
2. Standard curved segments will be slightly less than 90° and 180° due to the cutting allowance. This is not detrimental to the smoothness of travel across the joins. Full 90° and 180° segments and segments to any number of degrees can be supplied on request.

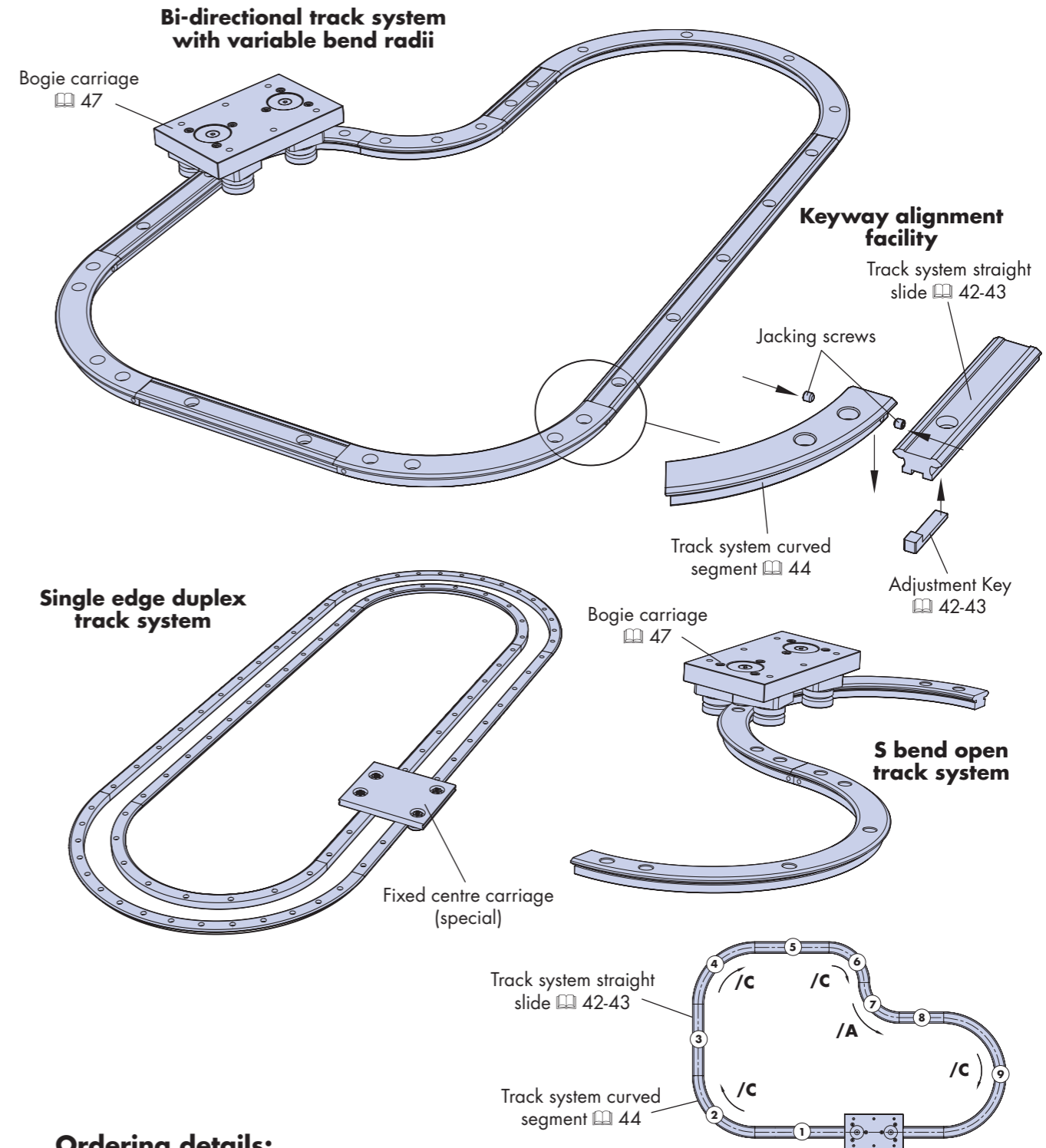
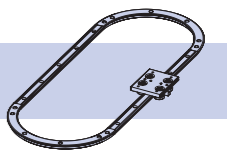

**Ordering details:**

Simply list the curved segments and straight slide part numbers in a clockwise sequence beginning at any point on the track system, see above plan view of track system. Curved segments should be designated suffix 'C' for a clockwise bend and suffix 'A' for an anticlockwise bend. Final item should be quantity and part number of the carriages required. For grade of track suitable for pre-drilled holes, specify track system type 'P'. To specify bleed lubrication facility 52.

- |                       |                                     |                      |                                     |
|-----------------------|-------------------------------------|----------------------|-------------------------------------|
| (1) TNS25 B420 2 x AK | — Track system straight slide 42-43 | (6) TR25 159 R90/C   | — Clockwise curved segment 44       |
| (2) TR25 255 R90/C    | — Clockwise curved segment 44       | (7) TR25 159 R90/A   | — Anticlockwise curved segment 44   |
| (3) TNS25 B159 2 x AK | — Track system straight slide 42-43 | (8) TNS25 B99 2 x AK | — Track system straight slide 42-43 |
| (4) TR25 255 R90/C    | — Clockwise curved segment 44       | (9) TR25 255 R180/C  | — Clockwise curved segment 44       |
| (5) TNS25 B165 2 x AK | — Track system straight slide 42-43 | 1 x BCP25            | — Bogie carriage 47                 |
- For fixed centre carriage 38-39



FCC carriage 38-39



BCP carriage 47



MLC carriage 48-49



Track slides 42-43 & 45



Track segments 44 & 46



Bleed Lubrication 52



Calculations 54-57

# Track System Double Edge Straight Slides



HepcoMotion track system straight slides are modified straight slides from Hepco's highly acclaimed GV3 system for which there is a separate catalogue, contact Hepco or visit [www.HepcoMotion.com](http://www.HepcoMotion.com). The slides are manufactured from quality high carbon steel, zone hardened on the V faces for maximum wear resistance and precision ground for high accuracy and conformity. The centre portion of the slide is left soft to allow for customising. Standard lengths are available up to 4020mm (1976mm in the TNMS 12 section) and unlimited lengths can be achieved by butting slides together. Slides are available in stainless steel for applications requiring corrosion resistance. Sets of short slides in incremental lengths can be supplied for customers wishing to extend a system in order to take up chain or belt stretch, see application example 19. For details please visit [www.HepcoMotion.com/PRT2datauk](http://www.HepcoMotion.com/PRT2datauk) and select datasheet No. 10 Slip Block adjustment. A bleed lubrication facility is available to channel lubricant direct to the running surfaces 52.

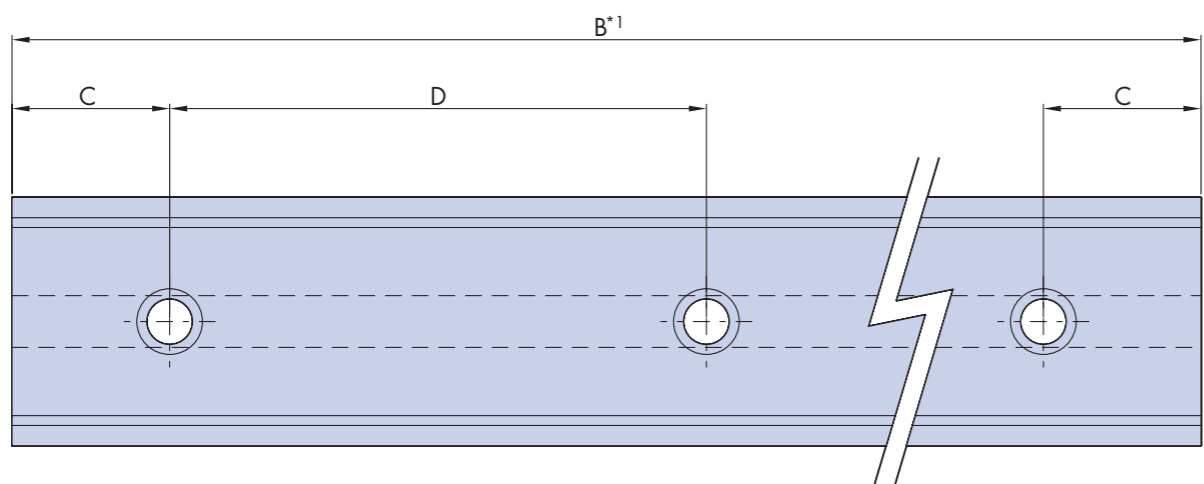

Bleed Lubrication is available as a standard option 52.

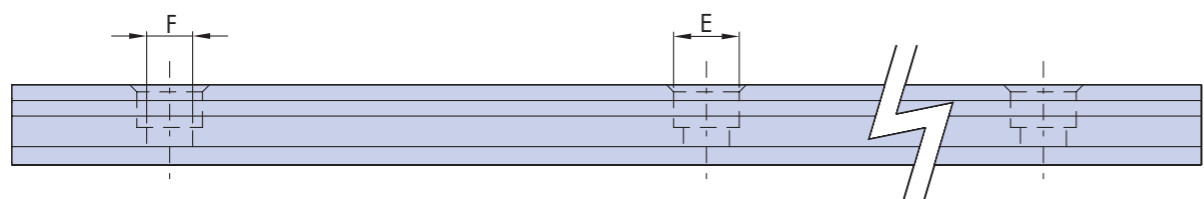

Part Number	A	A1 <sup>5</sup>	B (max)	C 0.0 -0.2	D	E Ø x Depth	F	DIN912 (not supplied)	G	H +0.05 0.00	H1	I ±0.025	J		K <sup>5</sup>	L	MØ (m6)	N	ØØ (K6)	P	Q	R	S	T	U	~kg/m	Part Number		
<b>TNMS 12</b>	12	12.37	1976	10	45	6 x 3	3.5	M3	3	4	1.8	8.5	1.7		6.2	0.2	4	+0.012 +0.004	-	4	+0.002 -0.006	6.75	2	11	4	3	1.5	0.5	<b>TNMS 12</b>
<b>TNV 20</b>	20	20.37	4020	20	90	8 x 4	4.5	M4	4.21	5	2	12	1.75		8	0.3	5	+0.012 +0.004	1.75	4	+0.002 -0.006	6	3.5	20.5	5.5	4	1.7	1.0	<b>TNV 20</b>
<b>TNS 25</b>	25	25.74	4020	20	90	10 x 5	5.5	M5	4.71	6	2.5	15	2.6		10	0.3	6	+0.012 +0.004	2.25	4	+0.002 -0.006	6	6	22	7	6	2.2	1.5	<b>TNS 25</b>
<b>TNM 44</b>	44	44.74	4020	20	90	11 x 6	7	M6	6.21	8	3	26	2.3		12.5	0.3	8	+0.015 +0.006	2.75	6	+0.002 -0.006	8	8	23	8	7	2.7	3.5	<b>TNM 44</b>
<b>TNL 76</b>	76	76.74	4020	30	180	20 x 12	14	M12	9.21	15	5	50	4.8		19.5	0.3	15	+0.018 +0.007	4.75	10	+0.002 -0.007	15	15	32	10	11	4.5	10	<b>TNL 76</b>

### Notes:

- Standard slide lengths are available in multiples of hole pitch 'D' + (2 x 'C') up to a maximum length per 'B' dimension in table above. Special length slides can be cut to order.
- Adjustment keys are required at every join between straight slide and curved slide. Please order accordingly (see ordering details). Please note that 'Q' dimension for the TNMS 12 & TNV 20 slides is stepped one end to fit keyway 'H'.
- Please note that dowel pins for the TNMS 12 slide are not stepped.
- Slides in their free unmounted state are not necessarily straight. They should be set to the required straightness when bolting down to the mounting surface at assembly.
- For track system requirements dimensions 'A1' and 'K' will be matched with corresponding dimensions 'F' and 'I', 44.

# Track System Double Edge Straight Slides

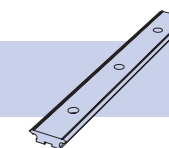

All straight slides within a track system are matched in essential respects both with each other and with their corresponding curved segments. They are ground square on the ends for precision butting and are marked with a reference number and sequence number for identification during installation and for replacement purposes. Opposing slides within a track system are ground to identical lengths. Adjustment keys are available to facilitate alignment with adjacent curved segments. Hepco dowel pins positioned at regular intervals along the slide keyway provide a convenient means of location and alignment. Alternatively, the ground datum faces of the slide may be set against a machined register in the mounting surface<sup>4</sup>.

### Adjustment Key<sup>2</sup> (AK)

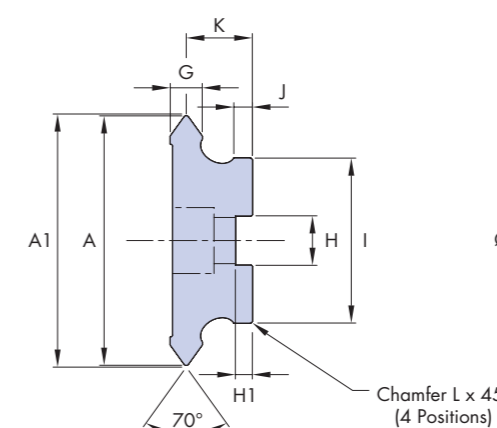
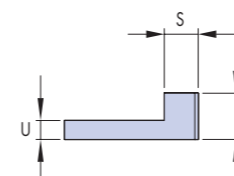
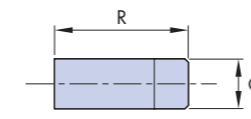

### Dowel Pin<sup>3</sup> (SDP)

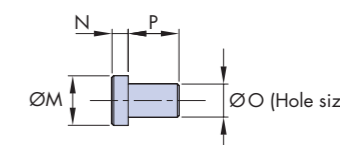

### Ordering details:

**Example:** (SS) **TNM 44** **B1500** (BLP) **2 x AK** (16 x SDP)

SS = Stainless Steel option  
Leave blank for steel version

Part Number

B (slide length) = 1500mm

SDP = Dowel pin (16-off)  
Leave blank if not required

AK = Adjustment key (2-off)

Bleed Lubrication: **BLP** = Plain bore insert 52  
**BLT** = Threaded insert 52  
Leave blank if not required

- Key
- Track system 40-41
- FCC carriage 38-39
- BCP carriage 47
- MLC carriage 48-49
- Track segments 44
- Bleed Lubrication 52
- XYZ ABC 123
- Calculations 54-57

## Track System Double Edge Curved Segments



HepcoMotion double edge track system curved segments are cut from stock rings or segments. They are matched in essential respects with their corresponding track system straight slides and ground square on the ends to a specified dimension relative to their true shape. A clearance keyway and tapped hole facility is incorporated each end to provide a method of alignment when assembled together with the mating key of the track system straight slide\*1. An additional fixing hole is provided adjacent to the keyway each end to give extra support at the join position for all segments except the TR12 93 & TR12 127. All track system curved segments are marked with a reference number and sequence number 40-41 and are available in stainless steel for applications requiring corrosion resistance. Segments to any number of degrees can be supplied to cater for all track system configurations.

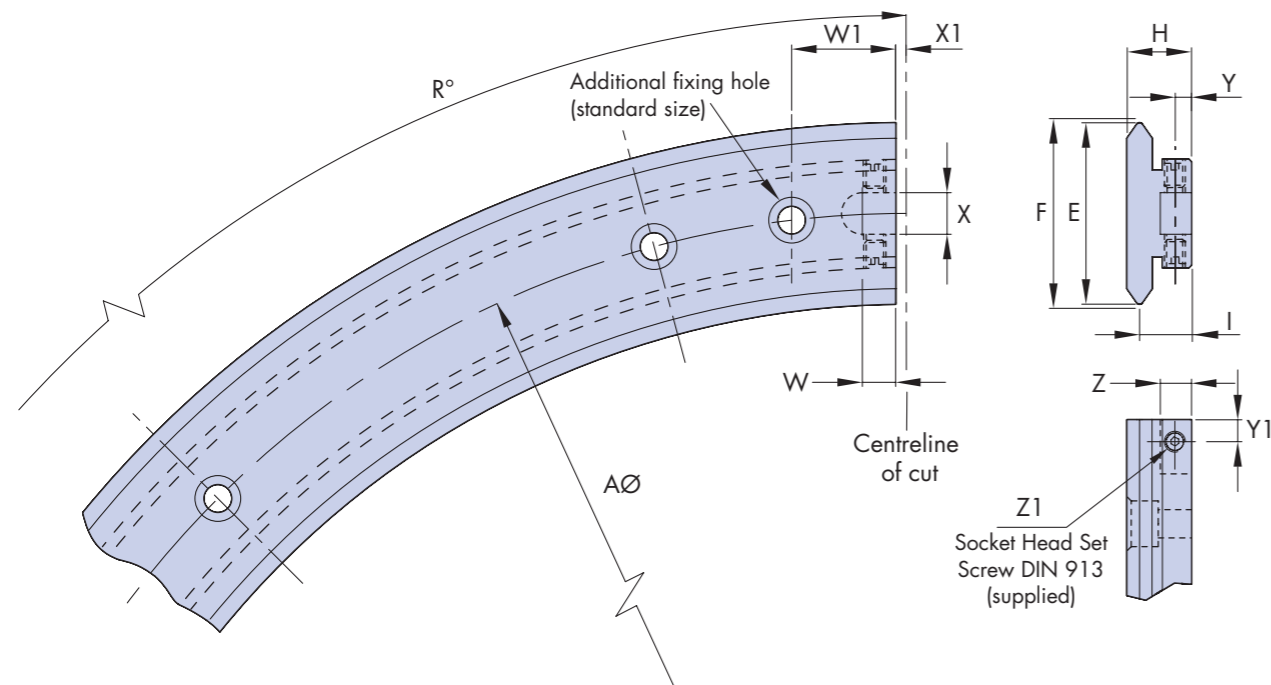

For all other details and dimensions see 26-27

Part Number	A	E	F	H	I	R°	W	W1	X	X1	Y	Y1	Z	Z1	
TR12 93	93	12	12.37	7.7	6.2	90	180	4.25	-	2.5	1.5	1.75	2	3.25	M2.5 x 3
TR12 127	127	12	12.37	7.7	6.2	90	180	4.25	-	2.5	1.5	1.75	2	3.25	M2.5 x 3
TR20 143	143	20	20.37	10	8	90	180	6	13	4	1.5	2	3.5	4.5	M3 x 4
TR20 210	210	20	20.37	10	8	90	180	6	15	4	1.5	2	3.5	4.5	M3 x 4
TR25 159	159	25	25.74	12.25	10	90	180	7	18	7	1.5	3	5	6.5	M4 x 4
TR25 255	255	25	25.74	12.25	10	90	180	7	20	7	1.5	3	5	6.5	M4 x 4
TR25 351	351	25	25.74	12.25	10	90	180	7	20	7	1.5	3	5	6.5	M4 x 4
TR44 468	468	44	44.74	15.5	12.5	90	180	8	25	10	2.5	4	6	7.5	M5 x 6
TR44 612	612	44	44.74	15.5	12.5	90	180	8	25	10	2.5	4	6	7.5	M5 x 6
TR76 799	799	76	76.74	24	19.5	90	180	10	30	18	2.5	6	7	11.5	M8 x 16
TR76 1033	1033	76	76.74	24	19.5	90	180	10	30	18	2.5	6	7	11.5	M8 x 16
TR76 1267	1267	76	76.74	24	19.5	90	180	10	30	18	2.5	6	7	11.5	M8 x 16
TR76 1501	1501	76	76.74	24	19.5	90	180	10	30	18	2.5	6	7	11.5	M8 x 16

### Notes:

- Some distortion may be present in segments in their free unmounted state. This may be overcome by bolting to the mounting surface and setting to adjacent slides using the keyway alignment facility 41. True Shape segments are available on request. Please visit [www.HepcoMotion.com/PRTdatauk](http://www.HepcoMotion.com/PRTdatauk) and select datasheet No.9 True Shape Rings & Segments.

### Ordering details:

#### Example:

**(SS)** TR44 612 **R90** **(N)**

**SS** = Stainless Steel option  
Leave blank for steel version

**N** = Tapped hole option, 26-27  
Leave blank if not required

**R90** = 90° segment  
**R180** = 180° segment

## Track System Single Edge Straight Slides



HepcoMotion track system single edge straight slides retain key features of the double edge slides, with precision ground finish and zone hardened V faces 42 & 43. Standard lengths are available up to 4020mm and unlimited lengths can be achieved by butting slides together. Slides are matched in essential respects both with each other and with their corresponding curved segments. They are ground square on the ends for precision butting and are marked with a reference number and sequence number for identification during installation and for replacement purposes 40 & 41. Slide pairs and opposing slides within a track system are ground to identical lengths

Track system single edge slides, can be used to construct a single edge duplex track system which provides a wide platform for supporting large components with extreme rigidity 17. The large rear face of the single edge slide enables a full width rack to be machined in the rear face providing for a strong drive. This can be used for the construction of a gear driven duplex track system 18.

Please visit [www.HepcoMotion.com/PRT2datauk](http://www.HepcoMotion.com/PRT2datauk) and select datasheet No. 4 Single Edge track systems.

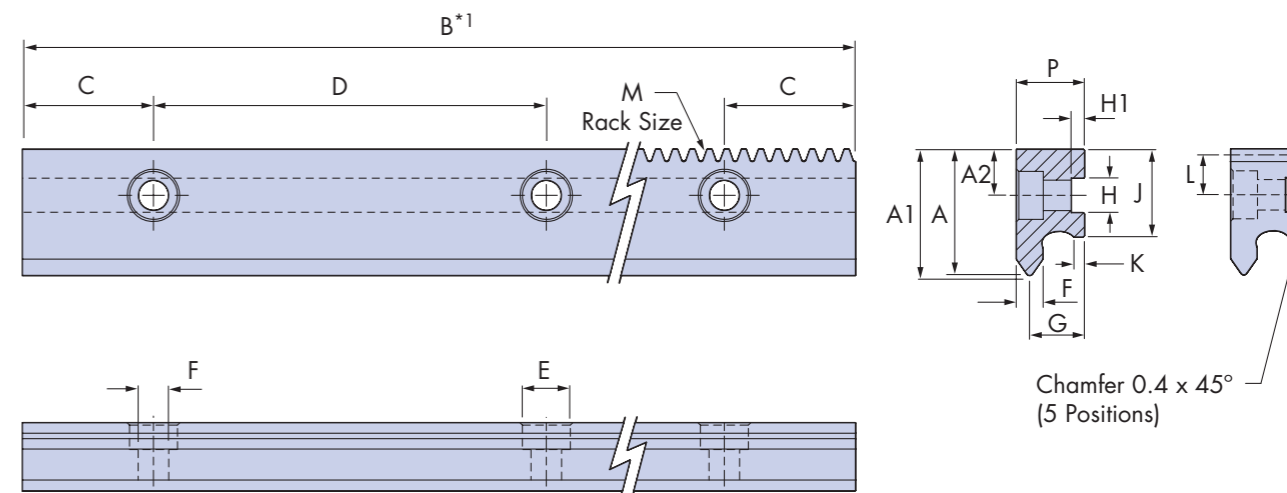

**Dowel Pin (SDP)**  
For details 42 - 43

Part Number	For use with	A	A1*3	A2	C	D	E	G*3	H	H1	J	K	L	M*4	P	kg/m	
TNSE	TRIS278, TRES376	21	21.37	8.5	20	90	10 x 5.1	5.5	10	6	2.5	16	2.6	7.4	1	12.35	1.6
TNME	TRIM482, TREM655	29	29.37	10.5	20	90	11 x 6.1	7	12.5	8	3	20	2.3	9.25	1.25	15.6	2.6

### Notes:

- Standard slide lengths are available in multiples of hole pitch 'D' + (2 x 'C') up to a 4020mm maximum length. Special length slides can be cut to order.
- Slides in their free unmounted state are not necessarily straight. They should be set to the required straightness when bolting down to the mounting surface at assembly.
- For track system requirements dimensions 'A1' and 'G' will be matched with corresponding dimensions 'F' and 'I', 46.
- Single edge slides with a rack, will be supplied in lengths that correspond to multiples of rack pitch. The position of the ends of the slides is accurately controlled to coincide with the centre of the rack root to give perfect running joints for slides and ring segments.

### Ordering details:

**Example:** **TNME B1500 (R) (BL) (16 x SDP)**

Part Number **TNME** **B1500** **(R)** **(BL)** **(16 x SDP)**

**B** (slide length) = 1500mm

**R** = Rack cut Slide  
Leave blank if not required

**BL** = Bleed Lubrication: **BLP** = Plain bore insert 52  
**BLT** = Threaded insert 52  
Leave blank if not required

**SDP** = Dowel pin (16-off)  
Leave blank if not required

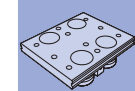

FCC carriage  
4 38-39



Track system  
40-41

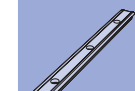

Track slides  
42-43

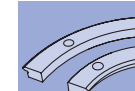

Single Edge  
Track segments  
46

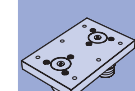

BCP carriage  
47

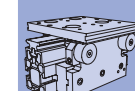

MLC carriage  
48-49

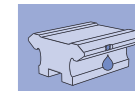

Bleed  
Lubrication  
52



Calculations  
54-57



## Track System Single Edge Curved Segments



HepcoMotion track system single edge curved segments are used in single edge duplex track systems 17, 18 & 41. Segments TRIS278 & TRES376 combine with TNSE track system single edges slides, and segments TRIM482 & TREM655 combine with TNME slides.

These segments are made to True Shape specification (please visit [www.HepcoMotion.com/PRT2datauk](http://www.HepcoMotion.com/PRT2datauk) and select datasheet No. 9 True Shape Rings & Segments). All segment pairs in a system are matched in essential respects with each other and with their corresponding straight slides. Ends are ground square to a specific dimension. An additional fixing hole is provided at each end of the segment to give extra support at the join position. It is recommended that all single edge track system components are aligned to a machined register. Hepco will supply suitable machined plates with precision registers, on request. Please see datasheet for design criteria.

Segments are available gear cut, for mating with rack cut straight slides, to produce a gear driven track system. For more details, and for information regarding assembly, please visit [www.HepcoMotion.com/PRT2datauk](http://www.HepcoMotion.com/PRT2datauk) and select datasheet No. 4 Single Edge Track Systems.

All track system single edge curved segments are marked with a reference and sequence number for identification and replacement purposes 40 & 41. Segments of any angle can be supplied to cater for all track system configurations.

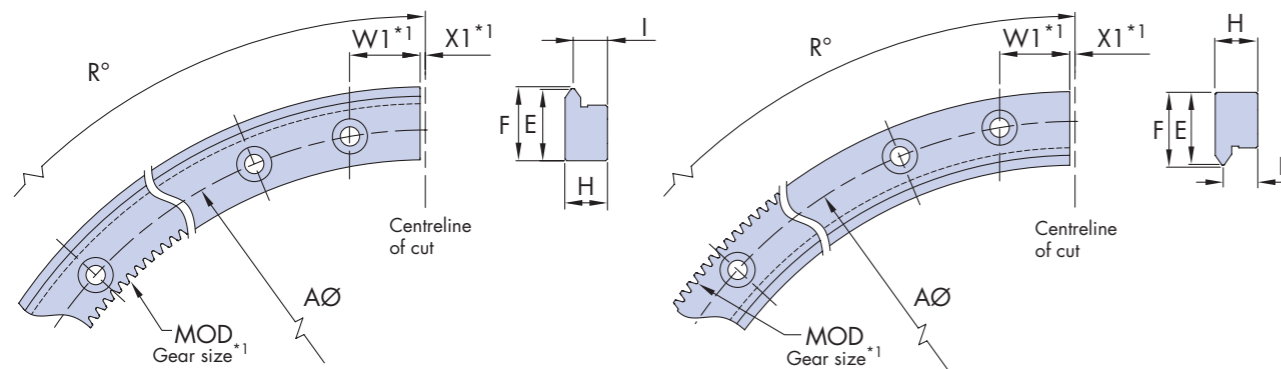

**External Single Edge Track Segment - TRE**

**Internal Single Edge Track Segment - TRI**

For all other details and dimensions see 28-31

Part Number	For use with	A	E	F	H	I ±0.025	R°	W1	X1 ±0.1	MOD*1
<b>TRIS 278</b>	TNSE	261	20.8	21.37	12.25	10	90	180	20	1.5
<b>TRES 376</b>	TNSE	351	20.8	21.37	12.25	10	90	180	20	1.5
<b>TRIM 482</b>	TNME	461.5	28.8	29.37	15.5	12.5	90	180	25	2.5
<b>TREM 655</b>	TNME	618.5	28.8	29.37	15.5	12.5	90	180	25	2.5

### Notes:

- Track system single edge segments with gear drive option Q or P will be ended to the root of a gear tooth. This will affect dimensions W1 and X1. For more details, please visit [www.HepcoMotion.com/PRT2datauk](http://www.HepcoMotion.com/PRT2datauk) and select datasheet No. 4 Single Edge track systems.

### Ordering details:

**Example:** **TRES 376 R90 (Q) (N)**

Part Number **TRES 376**

**R90** = 90° segment

**R180** = 180° segment

**(Q)** = Internal gear drive option  
Available on TRE option only

**(N)** = Tapped hole option, 28-31

**P** = External gear drive option  
Available on TRI option only

## Bogie Carriage

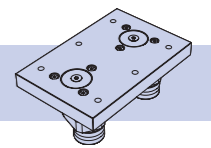

The HepcoMotion Bogie Carriage is designed for use with tracks where "S" bends or bends of differing radii are to be negotiated. Each bogie swivels on a special play free axial/radial ball bearing which is lubricated for life. This enables the bogie carriage to follow exactly the path of the track at all times. Carriage plates and bogie swivel plates are made from high strength aluminium alloy and finished anodised. Bogie carriages are supplied assembled and adjusted to suit the accompanying track system\*1. Customers are advised to specify the HepcoMotion bleed lubrication facility within the track 52 as lubricators cannot be fitted to bogie carriages. Special size carriage plates are available on request.

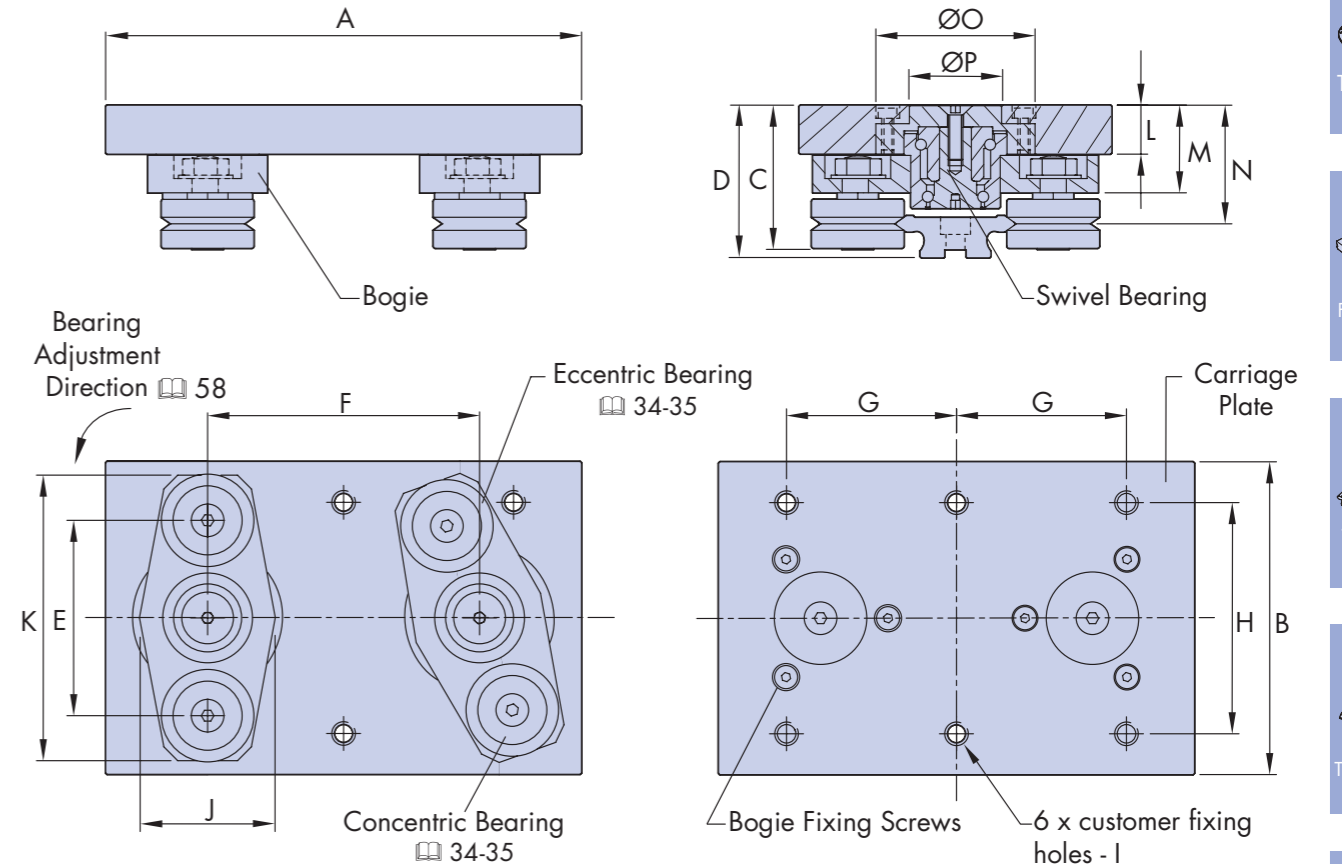

Part Number	For use with	A	B	C	D	E	F	G ±0.1	H ±0.1	I	J	K	L	M	N	ØO	ØP	Adjustment brace	-kg
<b>BCP 25</b>	TR 25	130	80	42.1	44.5	46.1	75	45	60	M6	38	75	15	25.5	34.5	46	29	AB-25	**
<b>BCP 44</b>	TR 44	175	115	53.8	56.5	71.9	100	62.5	85	M8	53	105	18	32.5	44	59	34	AB-44	**
<b>BCP 76</b>	TR 76	240	185	77.2	81	118.7	130	87.5	125	M10	72	170	24	42.5	61.5	100	70	AB-76	**

### Notes:

- In rare cases where adjustment of the eccentric bearings is required, the bogies must be removed from the carriage plate and bolted instead to the adjustment brace. This will mimic the carriage and provide access to the fixing nuts allowing adjustment of the eccentric bearings to take place.
- Please note that floating bearings 36 cannot be supplied with bogie bearings.

### Ordering details:

Part Number **BCP76 DR NS CHK**

**DR** = Double row bearings.

**NS** = Nitrile sealed option 34-35

**CHK** = Controlled height option 35  
Standard with DR bearings  
Leave blank if not required for twin bearing version

Adjustment brace\*1 **AB76**

## Moment Load Carriage Systems



HepcoMotion moment load carriage systems provide extra support and rigidity in applications where high downwards or offset loads are anticipated, typically at work stations. It is also possible to arrange for continuous support of the carriages all around the circuit. Moment load carriages are a variation of the standard fixed centre carriages 38-39 and are available in all 25 and 44 equivalent sizes. Carriages can be ordered complete with the carriage locking system and with either the fixed latch or trip latch belt connection facility.

Please visit [www.HepcoMotion.com/PRT2datauk](http://www.HepcoMotion.com/PRT2datauk) and select datasheet No. 5 Moment Load carriage systems for more details. For other compatible driven system components in main illustrations below see 50-51.

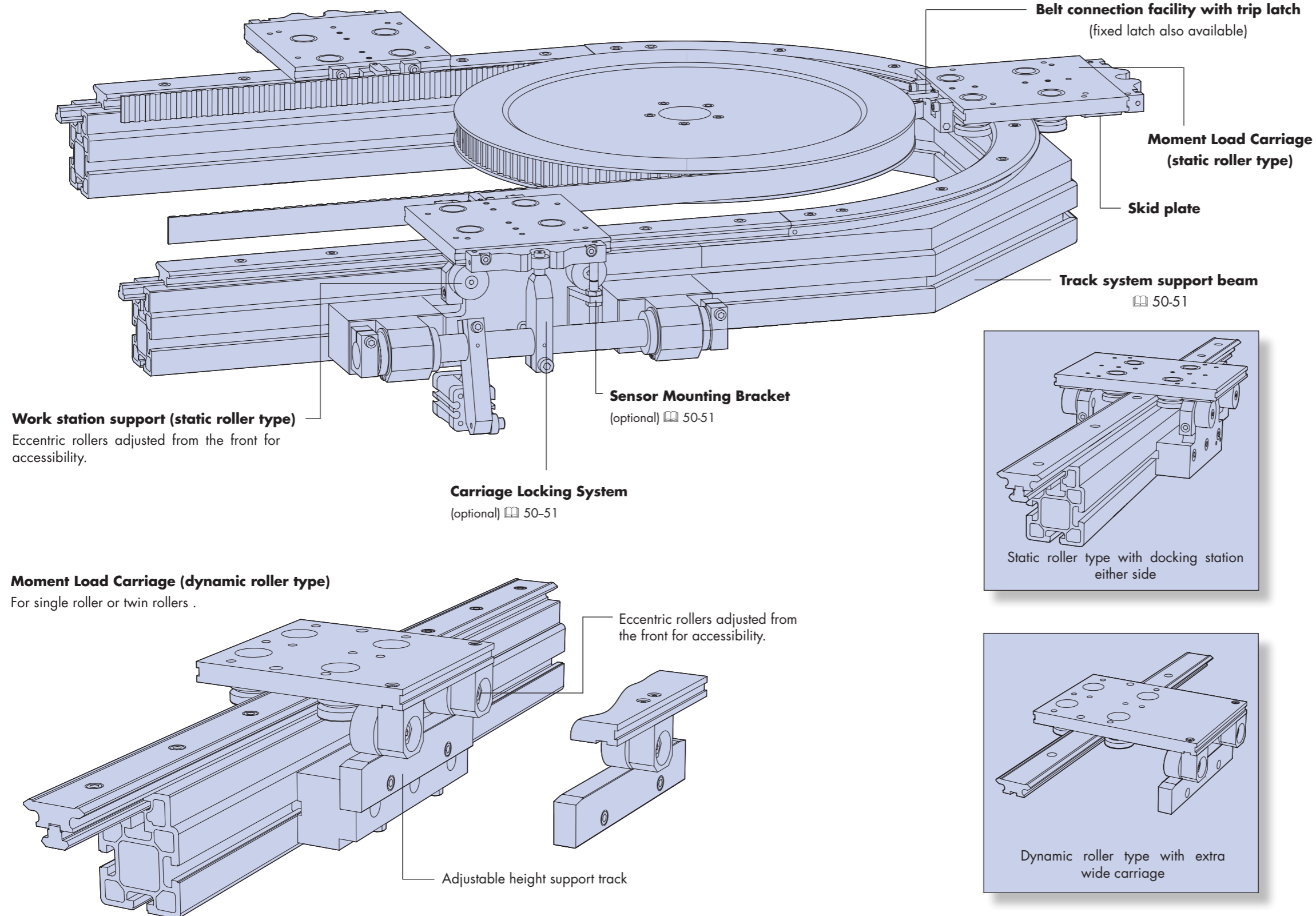

## Moment Load Carriage Systems

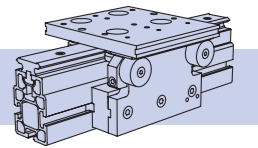

Moment load carriage systems are available with two types of work station support, both designed to connect to the track system support beam:

**Static roller type:** with eccentrically adjusted rollers attached to the framework bearing against a fixed skid plate on the underside of the carriage. This reduces the total number of rollers required and therefore the cost of a system with many carriages but few work stations.

**Dynamic roller type:** with eccentrically adjusted rollers attached to the underside of the carriage, bearing on adjustable height support track. The combination of these adjustable features facilitates set up where accuracy and alignment cannot be guaranteed or where continuous support for the carriage is required all around the circuit. Standard components, shown in the unframed illustrations, can also be used within customers special designs a number of which are shown in the framed illustrations. Special size carriages can be easily supplied.

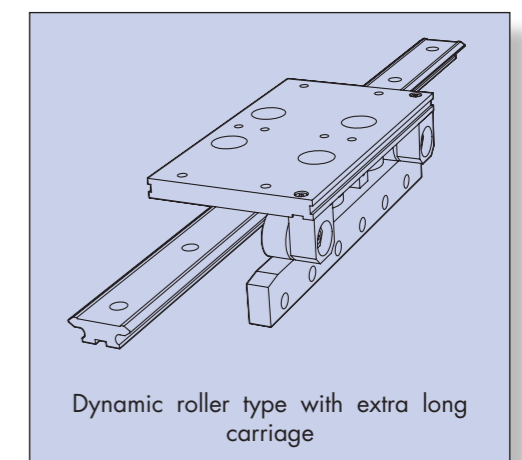
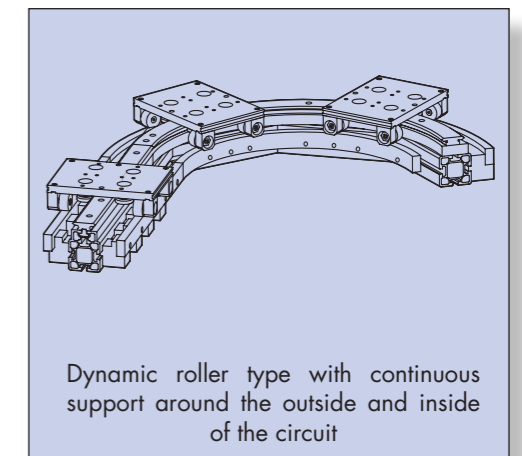
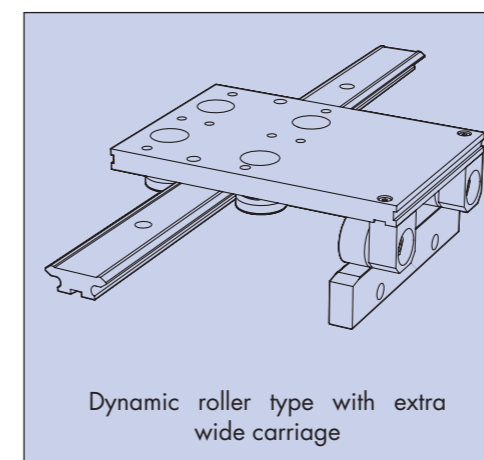
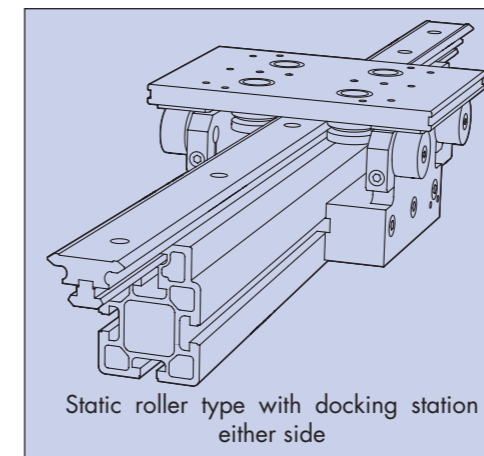
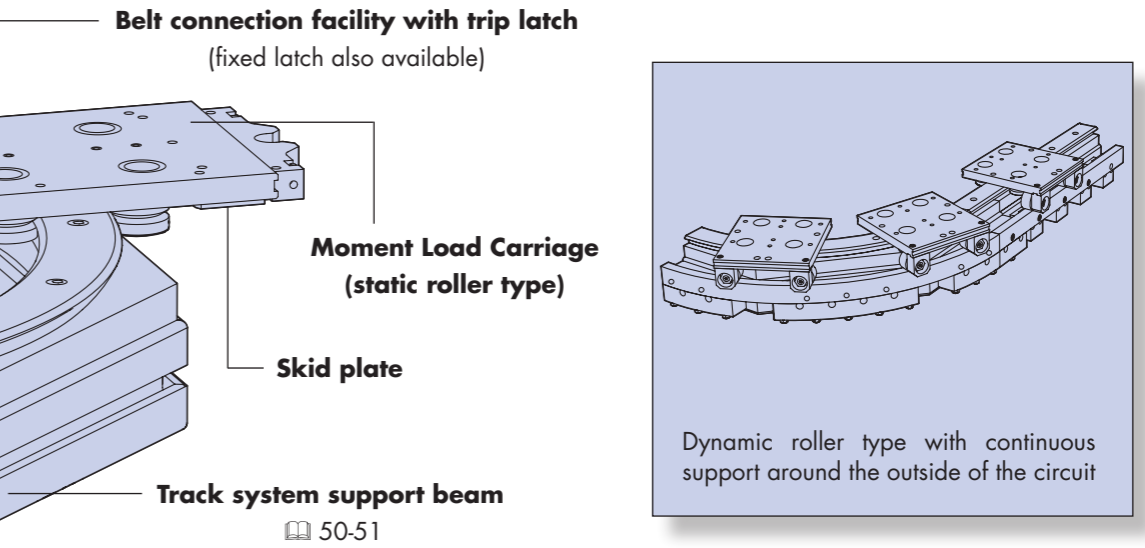

FCC carriage  
38-39



Track system  
40-41



Driven Track System Components  
50-51

HepcoMotion supply a comprehensive range of components and assemblies to enable the 25-351 and 44-612 size track systems to be incorporated into customers own designs complete with drive facility. Many of the components shown below can be also be used for other sizes of track system. The components are well proven having been used for many years in the HepcoMotion DTS, a complete ready to use Driven Track System highly recommended for customers able to use this fully assembled standard product.

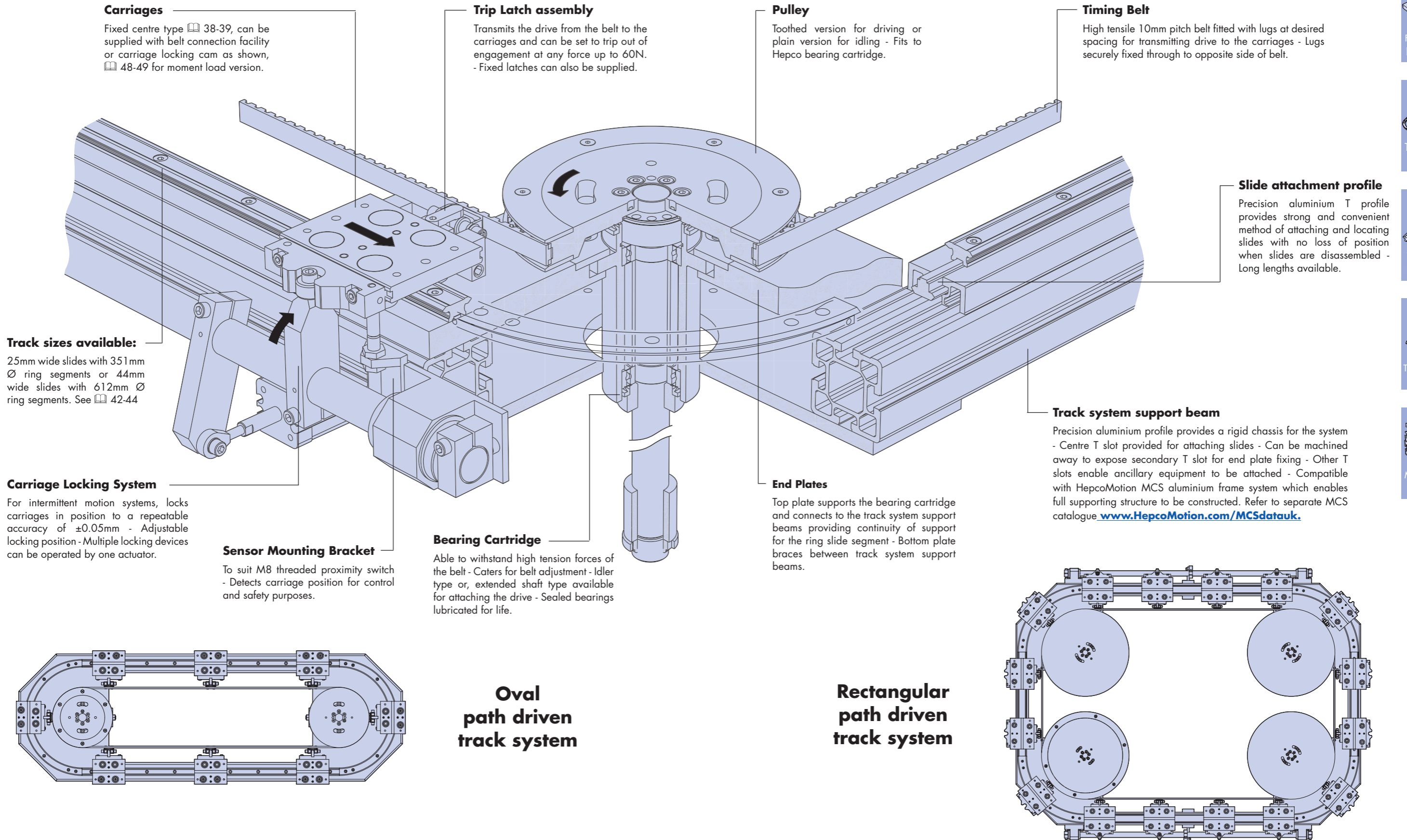

Moment load carriage systems 48-49 are also compatible with the DTS which is the full system as illustrated below and is comprehensively detailed in a separate catalogue. Please contact Hepco or visit [www.HepcoMotion.com](http://www.HepcoMotion.com).

For all details of Driven Track System components please visit [www.HepcoMotion.com/PRT2datauk](http://www.HepcoMotion.com/PRT2datauk) and select datasheet No. 8

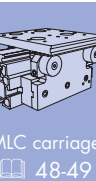

## Bleed Lubrication

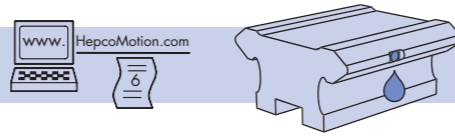

The HepcoMotion bleed lubrication facility channels lubricant direct to the V faces of a straight slide for best lubrication of a track system. The felt inserts of the lubricators fitted to the carriages\*1, collect the lubricant and distribute it around the circuit. Some of the lubricant is absorbed into the felts which act as reservoirs and help prevent excess oil accumulating. The bleed lubrication facility is available with either an M5 screw fitting insert or, an O ring seal insert as illustrated. Connection can be made to any centralised lubrication system or pressure feed canister (part no. PRT2BLC available from Hepco).

Also available is a highly efficient oil dispensing pump and controller which can be programmed to meter a set dose of lubricant according to the distance travelled by the carriages. Both the dose and distance travelled can be set according to the length of circuit and duty. For details of inserts and oil dispensing system, please visit [www.HepcoMotion.com/PRT2datauk](http://www.HepcoMotion.com/PRT2datauk) and select datasheet No. 6 Bleed Lubrication.

### Threaded Insert (T)

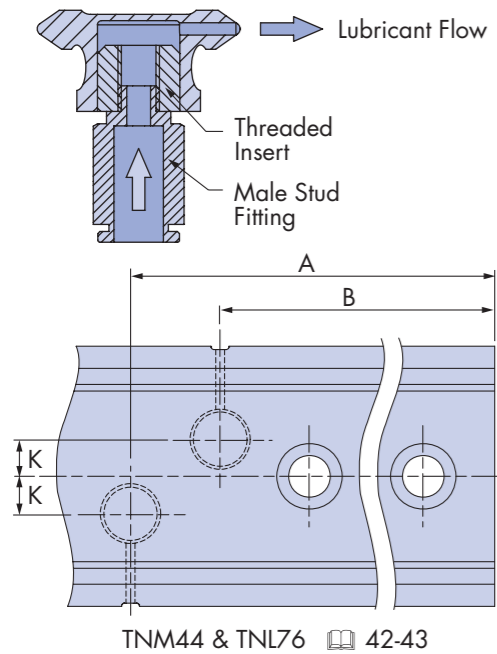

### Plain Bore Insert (P)

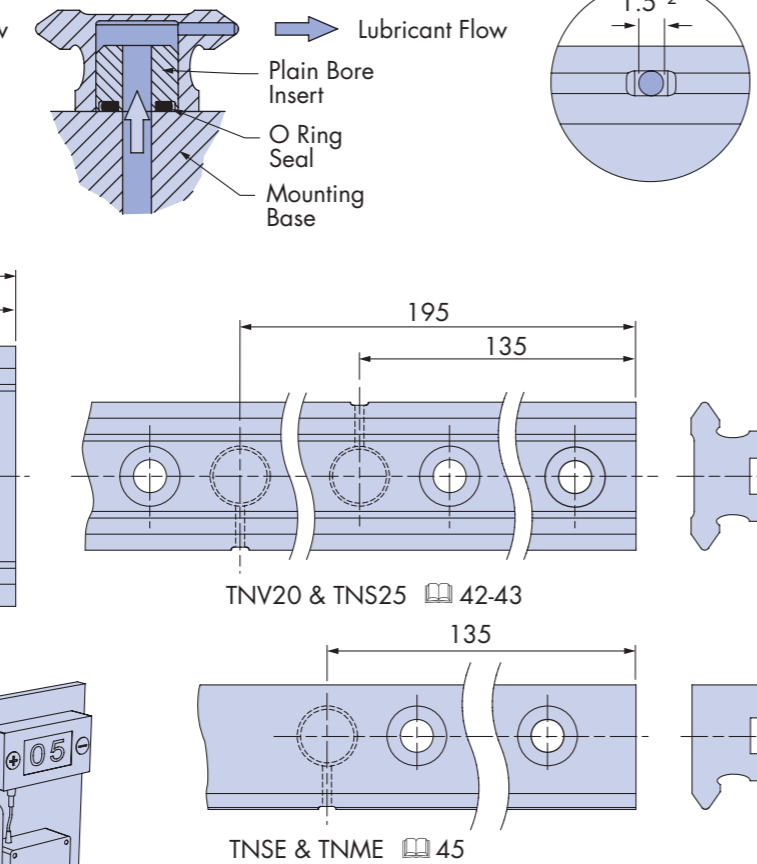

### Oil dispensing pump and controller

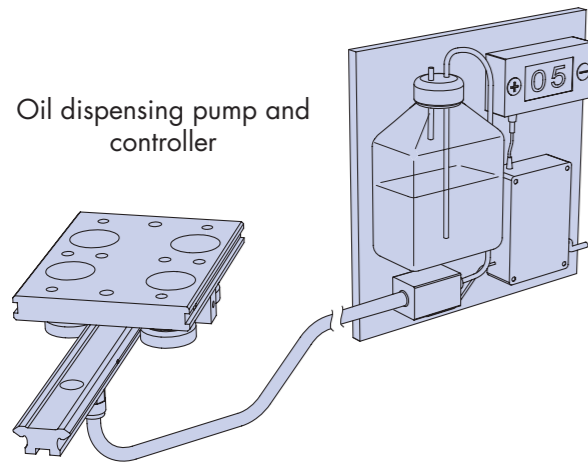

Part No.	A	B	K
TNM 44	195	135	6.25
TNL 76	360	240	18.0

For slide dimensions not specified please refer 42,43 & 45

### Notes:

- Track systems with bleed lubrication facility require only one in four carriages to be fitted with lubricators. This will also have the effect of reducing system friction.
- Hole Diameter for TNL76 slide is 2mm. For more details, please visit [www.HepcoMotion.com/PRT2datauk](http://www.HepcoMotion.com/PRT2datauk) and select datasheet No. 6 Bleed Lubrication.

### Ordering details:

#### Example:

SS TNM 44 BLP B1500 2 x AK

Please state BLP or BLT within the straight slide part number.  
42-43 for double edge straight slides.  
45 for single edge straight slides.

Bleed Lubrication facility: **BLP** = Plain bore insert  
**BLT** = Threaded insert

## Pinions

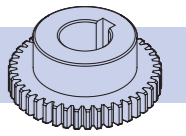

HepcoMotion pinions are compatible with gear cut ring slides, segments and ring discs 26-33. Gear teeth have a 20° pressure angle.

Pinions smaller than 1 module are made in unhardened stainless steel with teeth that conform to ISO 1328 grade 10. These are supplied with a plain bore (B type), with a keyway and set screw (BK type for bores of 8mm and above) or with set screw only (BK type for bores below 8mm\*1).

Pinions with modules of 1 and above have hardened and ground teeth, conform to ISO 1328 grade 6 and are available in both steel and stainless steel. These pinions are supplied with a plain bore (B type) or with keyway and set screw (BK type).

In all cases, the pinion and slide ring teeth should be lubricated. A range of pinions with integral shaft, suitable for hollow shaft connection to Hepco supplied AC geared motors and other motors is available from the HepcoMotion GV3 product range, please visit [www.HepcoMotion.com](http://www.HepcoMotion.com).

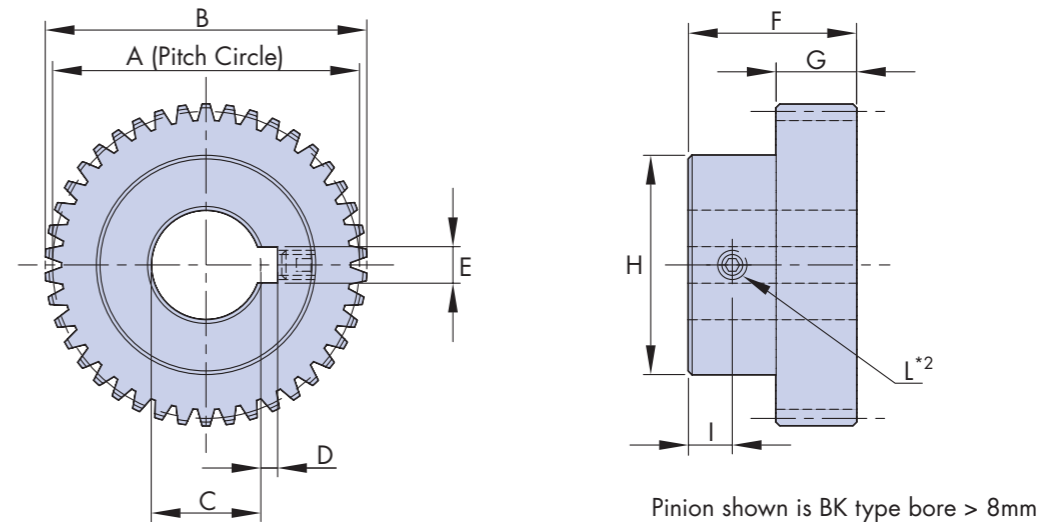

Part Number	For Use with				Material <sup>3</sup>	Condition <sup>4</sup>	Iso 1328 Grade	No. of teeth	Module	A $\emptyset$	B $\emptyset$	C	D <sup>1</sup>	E <sup>1</sup>	F	G	H	I	L <sup>2</sup>	g~
	R12	-	REV, RIV	-																
SSP04 W3.5 T42	R12	-	-	-	SS	x	10	42	0.4	16.8	17.6	5	-	-	10	3.5	10	3	M3	10
SSP07 W9 T28	-	-	REV, RIV	-	SS	x	10	28	0.7	19.6	21	5	-	-	17	9	16	4	M3	31
SSP08 W4 T48	R20	-	-	-	SS	x	10	48	0.8	38.4	40	12	1.8	4	12	4	26	4	M3	50
SSP08 W6 T48	R25	RD25	-	-	SS	x	10	48	0.8	38.4	40	12	1.8	4	14	6	26	4	M3	75
P10 W11 T42	-	-	RES, RIS	TNSE	ST/SS	✓	6	42	1	42	44	15	2.3	5	23	11	30	6	M4	160
P10 W7 T48	R44	RD44	-	-	ST/SS	✓	6	48	1	48	50	15	2.3	5	18.5	7	27	5.75	M4	170
P125 W14 T34	-	-	REM, RIM	TNME	ST/SS	✓	6	34	1.25	42.5	45	15	2.3	5	25.5	14	30	5.75	M4	200
P15 W12 T48	R76	-	-	-	ST/SS	✓	6	48	1.5	72	75	15	2.3	5	25	12	30	6.5	M4	350
P20 W20 T27	-	-	REL, RIL	-	ST/SS	✓	6	27	2	54	58	20	2.8	6	35	20	40	7.5	M5	430

### Notes:

- Small "BK" type pinions with bores below 8mm are supplied with set screw through to the bore but without keyway. It is usual practice to secure these pinions by means of a set screw onto a flat on the shaft or by using a taper pin.
- Pinions are supplied with a flat point set screw DIN 913 (ISO 4026).
- ST = Steel, SS = Stainless Steel.
- ✓ = Teeth hardened and ground. x = Teeth unhardened and unground.

### Ordering details:

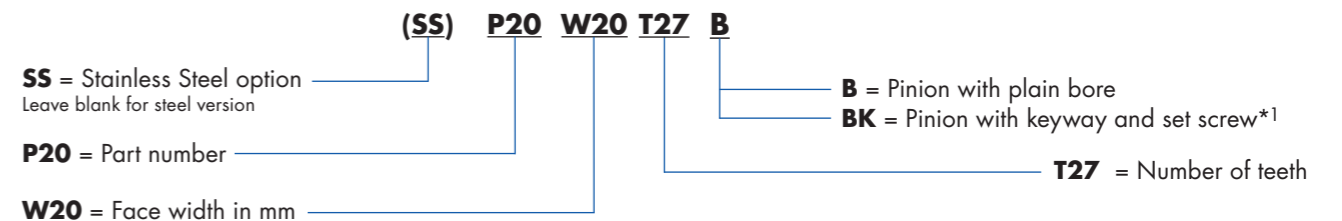

### Load Capacity and Life

The load capacity and life expectancy of HepcoMotion ring slides, segments and track systems is determined by many factors including the ring size, the type and number of bearings, the presence of lubrication, the magnitude and direction of loads, the speed and the distance travelled.

It is usual to run systems at much less than the maximum load to prolong life, which can be calculated using the data and formulae in this section. For calculation purposes, systems fall into two categories, those where a carriage runs on a ring slide, segment or track system and those where a ring slide is captivated and rotates in a number of bearings (or the similar arrangement where the ring slide is stationary and the bearings and load rotate).

Where possible, systems should be oiled using Hepco lubricators 37 and/or the bleed lubrication system 52. This will greatly extend system life.

### Systems with carriages

When calculating the life, first the load on each carriage should be resolved into the direct load components  $L_1$  and  $L_2$  and moment load components  $M$ ,  $M_V$  and  $M_S$ .

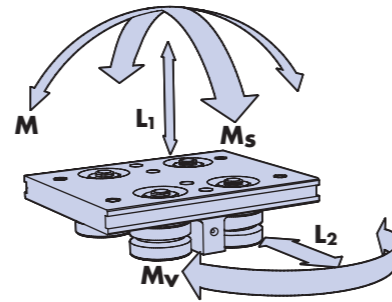

### Carriage Load Capacities

Capacities are shown for both 'dry' and 'lubricated' conditions - this refers to the bearing and slide 'V' contact, since all bearings are lubricated internally for life.

Values are based on shock-free duty.

Carriage Part Number	Dry System (Twin and DR Type Bearings)					Lubricated System (Twin Type Bearings)					Lubricated System (DR Type Bearings)				
	$L_{1(max)}$	$L_{2(max)}$	$M_S(max)$	$M_V(max)$	$M(max)$	$L_{1(max)}$	$L_{2(max)}$	$M_S(max)$	$M_V(max)$	$M(max)$	$L_{1(max)}$	$L_{2(max)}$	$M_S(max)$	$M_V(max)$	$M(max)$
	N	N	Nm	Nm	Nm	N	N	Nm	Nm	Nm	N	N	Nm	Nm	Nm
FCC 12 93	90	90	0.5	1	1	240	240	1.3	2.7	2.7	Not Available				
FCC 12 127	90	90	0.5	1	1	240	240	1.3	2.6	2.6	Not Available				
FCC 20 143	180	180	1.6	2.5	2.5	500	400	4.5	5.5	7	760	1200	7	16	10
FCC 20 210	180	180	1.6	2.7	2.7	500	400	4.5	6	7.5	760	1200	7	18	11
FCC 25 159	400	400	4.5	8.5	8.5	1280	1200	14	25	27	1600	3000	18	64	33
FCC 25 255	400	400	4.5	8	8	1280	1200	14	23	25	1600	3000	18	60	31
FCC 25 351	400	400	4.5	8.5	8.5	1280	1200	14	24	27	1600	3000	18	63	33
BCP 25	400	400	4.5	15	15	1280*	1200*	14*	45*	48*	1600*	3000*	18*	110*	60*
FCC 44 468	800	800	16	28	28	3200	2800	64	95	110	3600	6000	73	210	120
FCC 44 612	800	800	16	29	29	3200	2800	64	100	115	3600	6000	73	220	130
BCP 44	800	800	16	40	40	3200*	2800*	64*	140*	160*	3600*	6000*	73*	300*	180*
FCC 76 799	1800	1800	64	85	85	7200	6400	250	300	340	10000	10000	360	470	470
FCC 76 1033	1800	1800	64	105	105	7200	6400	250	360	410	10000	10000	360	570	570
FCC 76 1267	1800	1800	64	120	120	7200	6400	250	420	480	10000	10000	360	670	670
FCC 76 1501	1800	1800	64	140	140	7200	6400	250	480	550	10000	10000	360	770	770
BCP 76	1800	1800	64	115	115	7200*	6400*	250*	415*	460*	10000*	10000*	360*	650*	650*

The  $L_2$  &  $M_V$  load capacities for carriages using floating bearings 36 are the same as is shown above for DR bearings. The  $L_1$  &  $M_S$  load capacities for carriages using floating bearings are zero (they are free to float in these directions). Please note that bogie carriages (BCP) are not available with floating bearings.

To determine life, calculate the load factor  $L_f$  using equation [1] below, then use equation [3] or [4] to determine life for the system.

$$[1] \quad L_f = \frac{L_1}{L_{1(max)}} + \frac{L_2}{L_{2(max)}} + \frac{M_S}{M_{S(max)}} + \frac{M_V}{M_{V(max)}} + \frac{M}{M_{(max)}} \leq 1 \text{ or } 0.8 \text{ for stainless steel}$$

#### Notes:

- In heavily loaded applications using bogie carriages, the bogie swivel bearings can affect life. Applications for bogie carriages in which  $L_f$  is more than 0.43, calculated using the \*1 load figures from the table above, should be referred to Hepco to confirm suitability.
- When calculating  $L_2$  and  $M_S$  loadings, the centrifugal force must be included which acts radially outwards from the centre of mass (COM) of the moving object. Its magnitude is  $F = DV^2/R$ , where  $V$  is the velocity of the COM in m/s,  $R$  is the distance of the COM from the ring axis in metres and  $D$  is the mass in kg.  $F$  is in N (newtons).

### Systems with Ring Slides in Bearings

It is usual to space bearings equally around the ring\*1. When calculating the life, the load should be resolved into the direct load components  $L_A$  and  $L_R$  and the moment load component  $M$ , as shown in the diagram opposite.

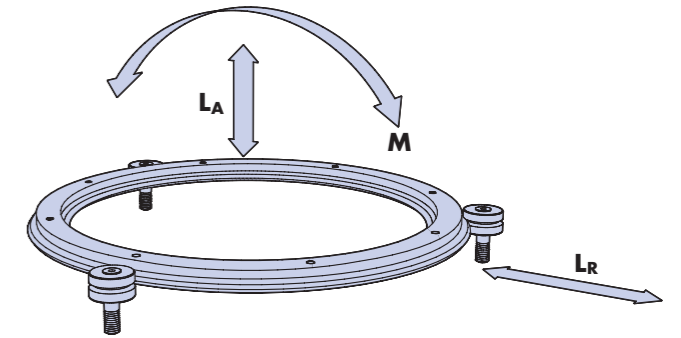

### System Load Capacities

Capacities are shown for both 'dry' and 'lubricated' conditions - this refers to the bearing and slide 'V' contact, since all bearings are lubricated internally for life.

Values are based on shock-free duty.

Bearing Part Numbers	Used with Ring Slides	Number of equally spaced bearings	Dry System (Twin and DR Type Bearings)			Lubricated System (Twin Type Bearings)			Lubricated System (DR Type Bearings)		
			$L_{A(max)}$	$L_{R(max)}$	$M(max)$	$L_{A(max)}$	$L_{R(max)}$	$M(max)$	$L_{A(max)}$	$L_{R(max)}$	$M(max)$
			N	N	Nm	N	N	Nm	N	N	Nm
...J13...	R12	3	67	38	$16 \times \varnothing c^{*4}$	180	102	$43 \times \varnothing c^{*4}$	Not Available		
		4	83	45	$19 \times \varnothing c^{*4}$	220	120	$52 \times \varnothing c^{*4}$	Not Available		
		Each additional 1	10	6	$2 \times \varnothing c^{*4}$	43	30	$9 \times \varnothing c^{*4}$	Not Available		
...J18...	R20 REV RIV	3	135	76	$32 \times \varnothing c^{*4}$	375	170	$90 \times \varnothing c^{*4}$	570	510	$135 \times \varnothing c^{*4}$
		4	165	90	$39 \times \varnothing c^{*4}$	465	200	$108 \times \varnothing c^{*4}$	700	600	$165 \times \varnothing c^{*4}$
		Each additional 1	21	13	$4 \times \varnothing c^{*4}$	90	50	$18 \times \varnothing c^{*4}$	135	150	$28 \times \varnothing c^{*4}$
...J25...	R25 RES RIS	3	300	170	$72 \times \varnothing c^{*4}$	960	510	$230 \times \varnothing c^{*4}$	1200	1280	$285 \times \varnothing c^{*4}$
		4	370	200	$87 \times \varnothing c^{*4}$	1190	600	$278 \times \varnothing c^{*4}$	1480	1500	$340 \times \varnothing c^{*4}$
		Each additional 1	48	30	$9 \times \varnothing c^{*4}$	230	150	$48 \times \varnothing c^{*4}$	285	375	$60 \times \varnothing c^{*4}$
...J34...	R44 REM RIM	3	600	340	$140 \times \varnothing c^{*4}$	2400	1200	$570 \times \varnothing c^{*4}$	2700	2550	$640 \times \varnothing c^{*4}$
		4	740	400	$170 \times \varnothing c^{*4}$	2950	1400	$690 \times \varnothing c^{*4}$	3340	3000	$780 \times \varnothing c^{*4}$
		Each additional 1	96	60	$19 \times \varnothing c^{*4}$	570	350	$120 \times \varnothing c^{*4}$	640	750	$135 \times \varnothing c^{*4}$
...J54...	R76 REL RIL	3	1350	765	$320 \times \varnothing c^{*4}$	5400	2740	$1290 \times \varnothing c^{*4}$	7500	4250	$1800 \times \varnothing c^{*4}$
		4	1670	900	$390 \times \varnothing c^{*4}$	6650	3200	$1560 \times \varnothing c^{*4}$	9300	5000	$2170 \times \varnothing c^{*4}$
		Each additional 1	210	130	$44 \times \varnothing c^{*4}$	1290	800	$270 \times \varnothing c^{*4}$	1800	1250	$375 \times \varnothing c^{*4}$

The  $L_R$  load capacities for systems using floating bearings 36 are the same as is shown above for DR bearings. The  $L_A$  &  $M$  load capacities for systems using floating bearings are zero (they are free to float in these directions).

To determine the life of this system, first obtain a value for the load factor  $L_f$  by entering the values for  $L_A$ ,  $L_R$  and  $M$  in respect of the proposed duty into equation [2] below, together with the maximum load capacities from the table above.

$$[2] \quad L_f = \frac{L_A}{L_{A(max)}} + \frac{L_R}{L_{R(max)}} + \frac{M}{M_{(max)}} \leq 1 \text{ or } 0.8 \text{ for stainless steel}$$

The life is then determined using equations [3] or [4] on the next page.

#### Notes:

- In some applications where the bearings rotate with the load, it may be beneficial to distribute the bearings unequally around the ring. Contact Hepco for application advice.
- SPEED OF OPERATION. Hepco ring slides, segments and track systems are rated for speeds of 1m/s without lubrication or 5m/s when lubricated, but take care to allow for inertial loads. Greater speeds may be tolerated at reduced loads. Contact Hepco for details.
- SHORT STROKE OPERATION. If the stroke length is less than five times the bearing outside diameter, then calculate the life as if the stroke is five times the bearing outside diameter.
- $\varnothing c$  is ring slide contact diameter in metres (the diameter of the circle through the mid position of the contact points between the bearings and the ring).

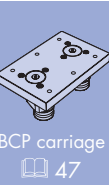
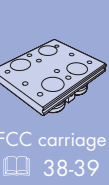
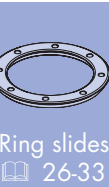
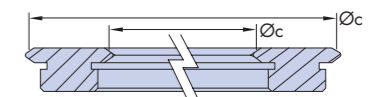

### Calculating System Life

With  $L_f$  determined for either a 4 bearing carriage 54 or for a ring system 55, the life in km can be calculated using one of the two equations below. In these equations, the Basic Life is taken from the table on the right in respect of the bearings and the lubrication condition applicable.

For dry systems use equation [3]:

$$[3] \quad \text{System life (km)} = \frac{B_L}{(0.03 + 0.97L_f)^2}$$

For lubricated systems use equation [4]:

$$[4] \quad \text{System life (km)} = \frac{B_L}{(0.03 + 0.97L_f)^3}$$

Example load-life calculations for PRT2 systems are available online. Please visit [www.HepcoMotion.com/PRT2datauk](http://www.HepcoMotion.com/PRT2datauk) and select datasheet No. 3 Load Life Calculations.

Bearings	Basic Life Dry	Basic Life Lubricated
...J13...	40	40
SS...J13...	30	30
...J18...	50	60
SS...J18...	35	45
...J18DR...	50	60
SS...J18DR...	35	45
...J25...	70	40
SS...J25...	40	25
...J25DR...	70	45
SS...J25DR...	40	35
...J34...	100	70
SS...J34...	60	50
...J34DR...	100	160
SS...J34DR...	60	120
...J54...	150	150
SS...J54...	100	110
...J54DR...	150	280
SS...J54DR...	100	220

The above data assumes that steel bearings run on steel rings, and that stainless steel bearings run on stainless steel rings.

### Industry Standard Bearing Load Capacities

The load capacities and calculations in the previous sections have been carefully developed, and are based on rigorous testing and years of application experience.

Many competitive systems use industry standard, theoretically derived figures for bearing static and dynamic load capacities, which are generally higher than the true working load capacities which Hepco uses.

The table below shows the industry standard static ( $C_{OR}$  &  $C_{OA}$ ) and dynamic ( $C_R$  &  $C_A$ ) load figures for PRT2 bearings (R & A subscripts indicate radial & axial loading). These are included principally to allow the comparison of Hepco components with those from other manufacturers. It is NOT recommended that they are used for determining system life.

For each of two Twin Bearings	Bearing Dynamic & Static Load Capacities (N)				For Double Row Bearings	Bearing Dynamic & Static Load Capacities (N)				For Floating Bearings	Dynamic & Static Load Capacities (N)	
	$C_R$	$C_A$	$C_{OR}$	$C_{OA}$		$C_R$	$C_A$	$C_{OR}$	$C_{OA}$		$C_R$	$C_{OR}$
...J13...	695	194	265	74	-	-	-	-	-	-	-	-
...J18...	1438	419	593	173	...J18DR...	2301	857	1168	435	-	-	-
...J25...	3237	791	1333	326	...J25DR...	5214	1618	2646	821	...FJ25...	4900	6100
...J34...	5291	1270	2600	557	...J34DR...	9293	2523	5018	1362	...FJ34...	11500	12500
...J54...	13595	2320	6657	1136	...J54DR...	21373	4601	12899	2777	...FJ54...	21500	28900

The above load capacities apply to standard steel bearings. Stainless steel bearings may be different.

### Pinion and Gear Force Calculations

The driving force which can be transmitted through a pinion and gear will depend on the tooth (Mod) size, the size of pinion and ring or segment selected, the length of stroke and the desired life.

The table below details the tangential driving force in newtons (N) for all pinion and ring combinations and for a useful range of design lives. The figures assume that the pinion revolves around the complete ring, rather than moving to and fro over just a portion of the ring's teeth. The load capacity for shorter strokes will be lower.

All figures assume ideal lubrication and pinion contact conditions. It is recommended that a safety factor be applied when selecting gear and pinion components. This table is suitable for selection of parts, but please contact Hepco if a specific calculation is required for a particular application.

For rack-cut track systems using single edge straight slides, the max driving force will be the same as for the largest diameter RL... ring which has the matching section size.

Pinion Part Number	Used with Ring	Max Working Tangential Load (N)		
		Life - distance travelled around Ring Gear		
		1 000 km	5 000 km	25 000 km
SSP04 W3.5 T42	R12 93	50	30	25
	R12 127	40	30	25
SSP07 W9 T28	REV 156	150	100	75
	REV 223	155	100	80
	RIV 161	150	100	75
	RIV 228	155	100	80
SSP08 W4 T48	R20 143	100	80	60
	R20 210	110	85	65
SSP08 W6 T48	R25 159	155	120	95
	R25 255	165	125	100
	R25 351	170	130	100
P10 W11 T42 & SSP10 W11 T42	RES 184	960	730	530
	RES 280	970	850	640
	RES 376	970	880	660
	RIS 182	960	730	530

Pinion Part Number	Used with Ring	Max Working Tangential Load (N)		
		Life - distance travelled around Ring Gear		
		1 000 km	5 000 km	25 000 km
P10 W11 T42 & SSP10 W11 T42	RIS 278	970	850	640
	RIS 374	970	880	680
P10 W7 T48 & SS P10 W7 T48	R44 468	630	585	470
	R44 612	760	585	470
P125 W14 T34 & SS P125 W14 T34	REM 505	1510	1400	960
	REM 655	1820	1400	990
	RIM 482	1510	1400	970
	RIM 627	1820	1400	990
P15 W12 T48 & SS P15 W12 T48	R76 799	1950	1560	1290
	R76 1033	1950	1640	1290
	R76 1267	1950	1640	1290
	R76 1501	1950	1640	1290
P20 W20 T27 & SS P20 W20 T27	REL 874	3990	2530	1890
	RIL 812	3990	2530	1890

For racks on TNSE...R slides use RIS 374 figures & for TNME...R slides use RIM 627 figures

### Fixed Centre Carriage Play at Track System Joints

HepcoMotion fixed centre carriages have the same fit on both straight slides and curved segments in a track system. As the carriage traverses the join between these two components, slight play develops between each pair of opposing bearings. The maximum play is given in the table below.

Carriage Type	FCC 12 93	FCC 12 127	FCC 20 143	FCC 20 210	FCC 25 159	FCC 25 255	FCC 25 351	FCC 44 468	FCC 44 612	FCC 76 799	FCC 76 1033	FCC 76 1267	FCC 76 1501
Maximum Clearance /mm	0.17	0.08	0.18	0.10	0.47*	0.15	0.09	0.21	0.14	0.22	0.19	0.17	0.16

These figures are theoretical clearances. In most applications, the bearings are slightly preloaded against the slides, and some of this clearance will appear as a "relaxation" of the system. In these instances the carriage will have a slightly freer movement as it traverses between the straight and curved section than when the carriage is fully on the straight slide or curved segment. In most duties the clearance or momentary reduction in preload will not present an issue, however, in some applications it may be undesirable. In such cases customers should consider using the Hepco bogie type carriage 47, which does not develop play in the same way when traversing from straight to curved sections.

\* The FCC 25 159 has greater than normal clearance. This will be noticeable, but not detrimental in many applications.



Ring slides  
26-33



Bearings  
34-36



FCC carriage  
38-39



BCP carriage  
47



Track system  
40-41

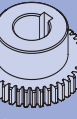

Pinions  
53

## Adjusting method for Through Fixing Eccentric bearings

To get the best performance from a HepcoMotion ring slide system, it must be correctly assembled and adjusted. To fit a carriage, the concentric bearings should be fully tightened and the eccentric bearings semi-tightened and rotated to their outermost position. The carriage may then be introduced to the slide as shown below. **Both eccentric bearings should be rotated in the direction of the arrow shown opposite**, until the bearings captivate the slide with minimal preload. To fit a ring slide into encircling bearings, all eccentrics should be fully adjusted away from the V edge to permit the ring to be engaged. The eccentrics may then be adjusted onto the V edge as for carriages.

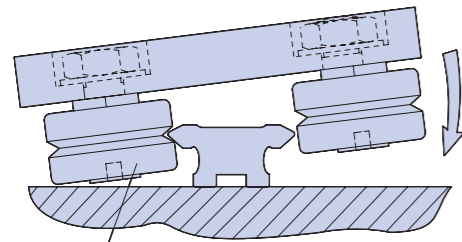
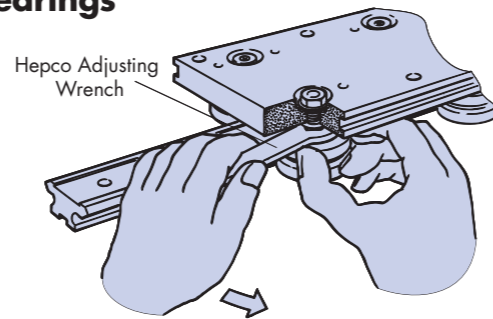

Concentric Bearing

The correct condition of adjustment should be assessed by rotating the bearings by holding them between forefinger and thumb whilst preventing the ring slide or carriage from moving such that the bearings skid against the slide. A uniform degree of resistance should be felt, but the bearings should be able to be rotated without difficulty. Once adjusted in this manner, the eccentric bearing fixing nuts should be fully tightened to the relevant torque value shown in the table below whilst preventing the bearing stud from further rotation, by means of the specified Hepco Adjusting Wrench. A further check should be made to ensure the correct condition of adjustment.

It should be noted that the load/life calculations assume a light preload, as is described above. Systems which are preloaded more heavily than this will suffer a reduction in the life as compared with that predicted by the calculations.

In some circumstances, it may be difficult to gain access to the hexagonal flange for system adjustment. In these situations it is possible to adjust by rotating the eccentric bearing using an allen key located in the hexagonal socket in the end of the stud and tightening the fixing nut at the same time using the Hepco socket tool, see table below. Due to the reduced control associated with this method, it is only recommended when the adjusting wrench method above is not possible.

When adjusting fixed centre carriages the lubricators should first be removed in order to gain access. When adjusting bogie carriages, the steps outlined in the adjustment procedure on 47, should be observed. In cases where an assembled system is supplied, the carriages will be supplied pre-adjusted.

## Alternative adjusting method using end socket in journal

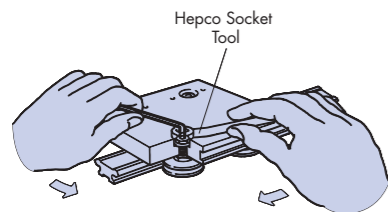

## Adjusting method for Blind Hole Eccentric bearings

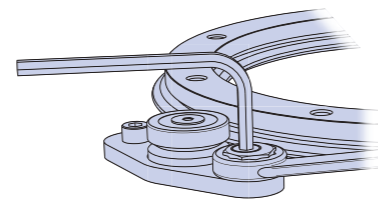

## Ring and Track System Installation

For details on Ring and Track system installation, please visit [www.HepcoMotion.com/PRT2datauk](http://www.HepcoMotion.com/PRT2datauk) and select datasheet No. 2 Installation details.

## Bearing Adjusting Tools and Tightening Torques

When ordering individual components for the first time an Adjusting Wrench or Socket Tool should be ordered, these are only available from Hepco.

	Bearing Ø				
	13	18	25	34	54
<b>Adjusting Wrench</b>	AT13	AT18	AT25	AT34	AT54
<b>Socket Tool</b>	-	RT6	RT8	RT10	RT14
<b>Fixing Nut Torque</b>	2 Nm	7 Nm	18 Nm	33 Nm	90 Nm

## Ring Slides and Segments

Material and finish:

**Standard version:** High carbon steel, hardened on V faces. Ground on all main surfaces to N5 finish.

**Stainless steel version:** Special martensitic stainless steel generally conforming to 420 series, hardened on V faces. Ground on all main surfaces to N5 finish, other faces polished.

## Track System Slides

Material and finish:

**Standard version:** High carbon-chromium steel, hardened on V faces. Ground on all main surfaces to N5 finish, other faces chemically blacked.

**Stainless steel version:** Special martensitic stainless steel generally conforming to 420 series, hardened on V faces. Ground on all main surfaces to N5 finish.

## Bearings

Bearing rings, balls, rollers:

**Standard version:** Carbon-chromium bearing steel AISI 52100 hardened and tempered.

**Stainless steel version:** AISI 440C stainless bearing steel, hardened and tempered.

Shields:

**Standard version only:** Steel with bright zinc plated finish.

Seals:

Nitrile rubber.

Cages:

Plastic (metal for floating bearing).

Studs:

**Standard version:** High tensile steel with chemical black finish.

**Stainless steel version:** AISI 303 series stainless steel.

Temperature range:

**All versions:** -20°C to +120°C.

Bearings for low temperature, high temperature and vacuum use are available on request.

## Carriage Plates

Material:

**All versions:** High strength aluminium alloy

Finish:

**Standard version:** Clear anodised.

**Stainless steel version:** Special finish approved by US Department of Agriculture for food use. Stainless steel carriage plates available on request.

## Lubricators

Material:

Impact resistant thermoplastic with felt wiper.

Fixings:

Stainless steel.

Temperature range:

-20°C to +60°C.

Lubricant:

Slideway oil with viscosity 68 cSt or similar.

## Pinions

Material and finish (<Mod1):

**Stainless steel only version:** 300 series stainless steel, finish as gearcut. ISO 1328 accuracy grade 10.

Material and finish (≥ Mod1)

**Standard version:** Case hardened carburising steel. Ground on teeth to N5 finish. ISO 1328 accuracy grade 6.

**Stainless steel version:** Hardened 420 series stainless steel. Ground on teeth and all main surfaces to N5 finish. ISO 1328 accuracy grade 6.

## Friction

Coefficient of friction for lubricated systems is typically 0.02. Lubricators will add between 0.5 (for LB12) & 2N (for LB54) each.

## Maximum Speed

Generally 1m/s for dry (unlubricated) operation and 5m/s when lubricated. Greater speeds may be possible at reduced loads. Contact Hepco for details.



Ring slides & segments 26-33

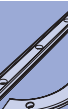

Track slides & segments 42-46



Bearings 34-36



Carriages 38-39



Lubricators 37



Pinions 53

## Rolled Rings, Segments & Specials

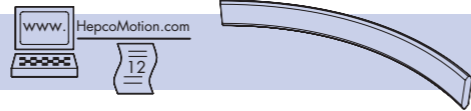

The HepcoMotion facility for rolled rings and segments provides a means of achieving circular guidance of unlimited maximum diameter. Most slide sections in P3 grade from Hepco's highly acclaimed GV3 range can be rolled to achieve curved segments in either edge hardened or unhardened condition. Segments can be butt joined to make complete rings or to make track systems as shown below.

Please visit: [www.HepcoMotion.com/PRT2datauk](http://www.HepcoMotion.com/PRT2datauk) and select datasheet No. 12 Rolled Rings, Segments & Track Systems. The HepcoMotion GV3 catalogue is also available on this web site.

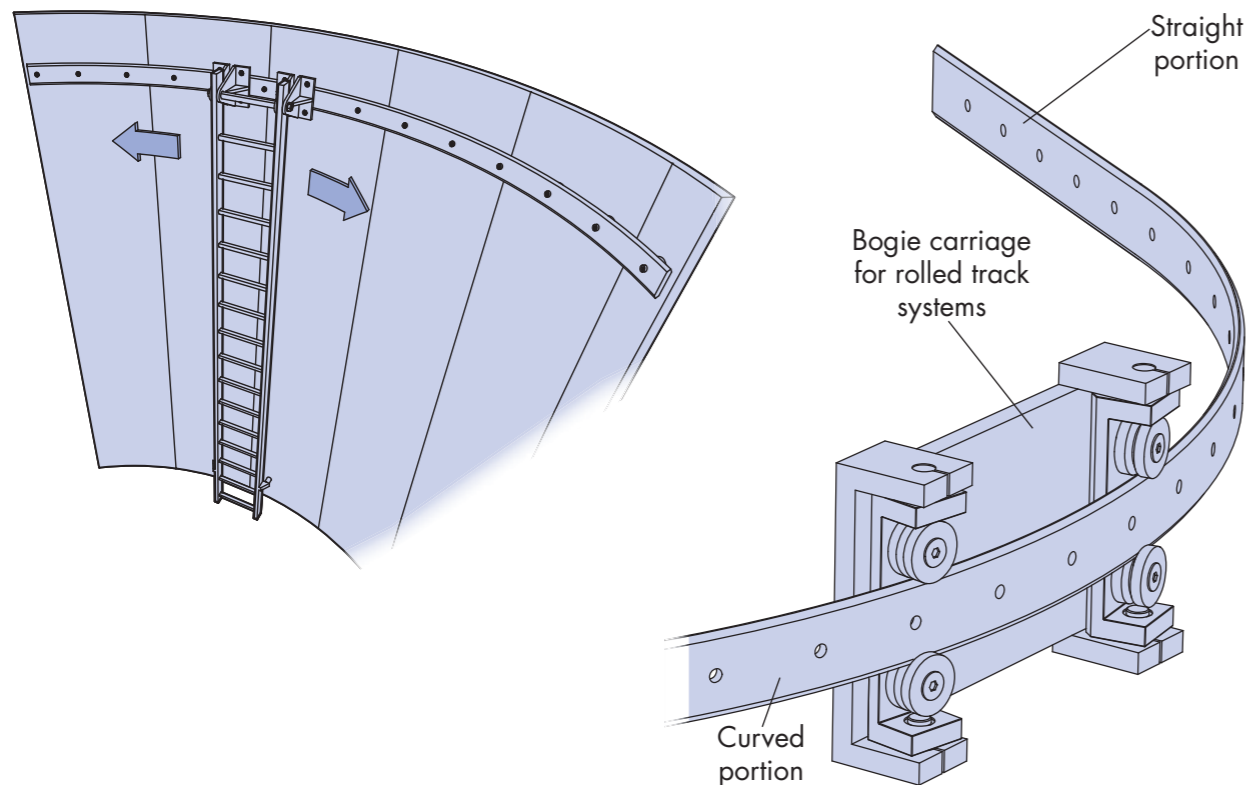
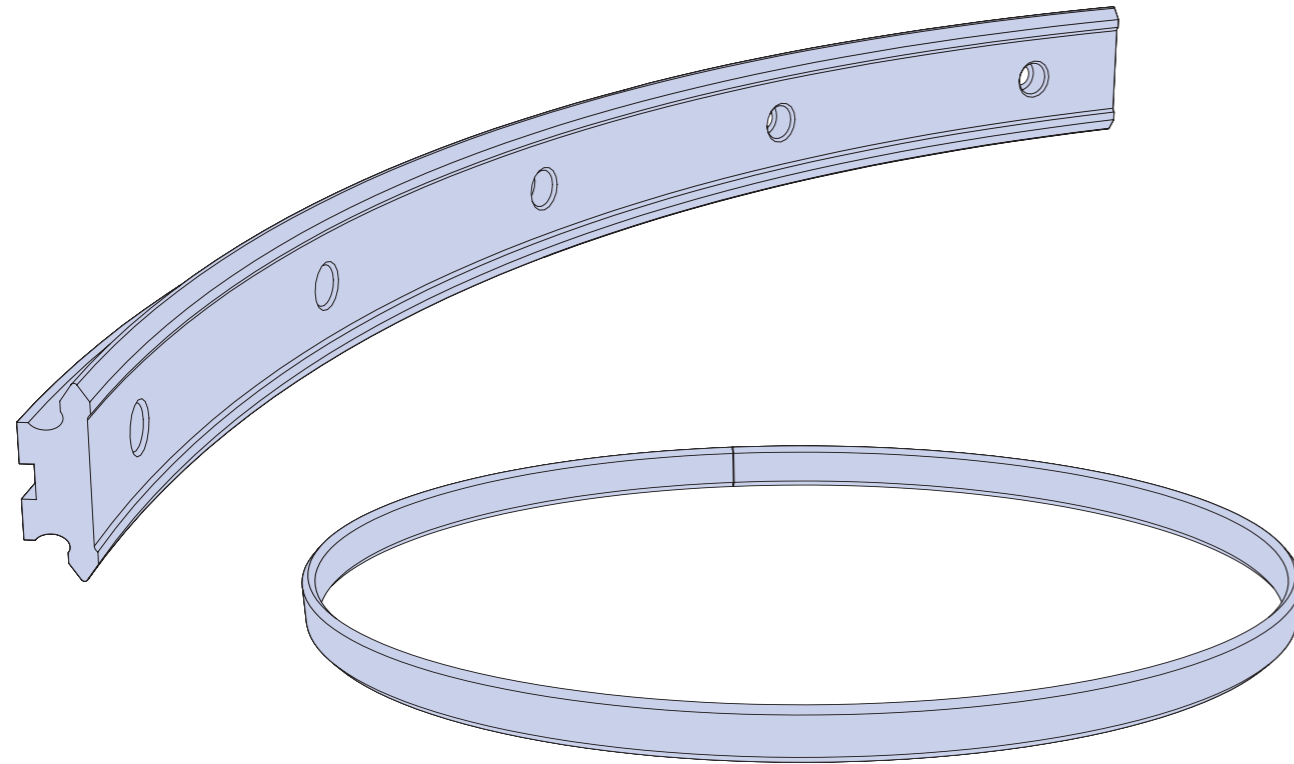

## Rolled Rings, Segments & Specials

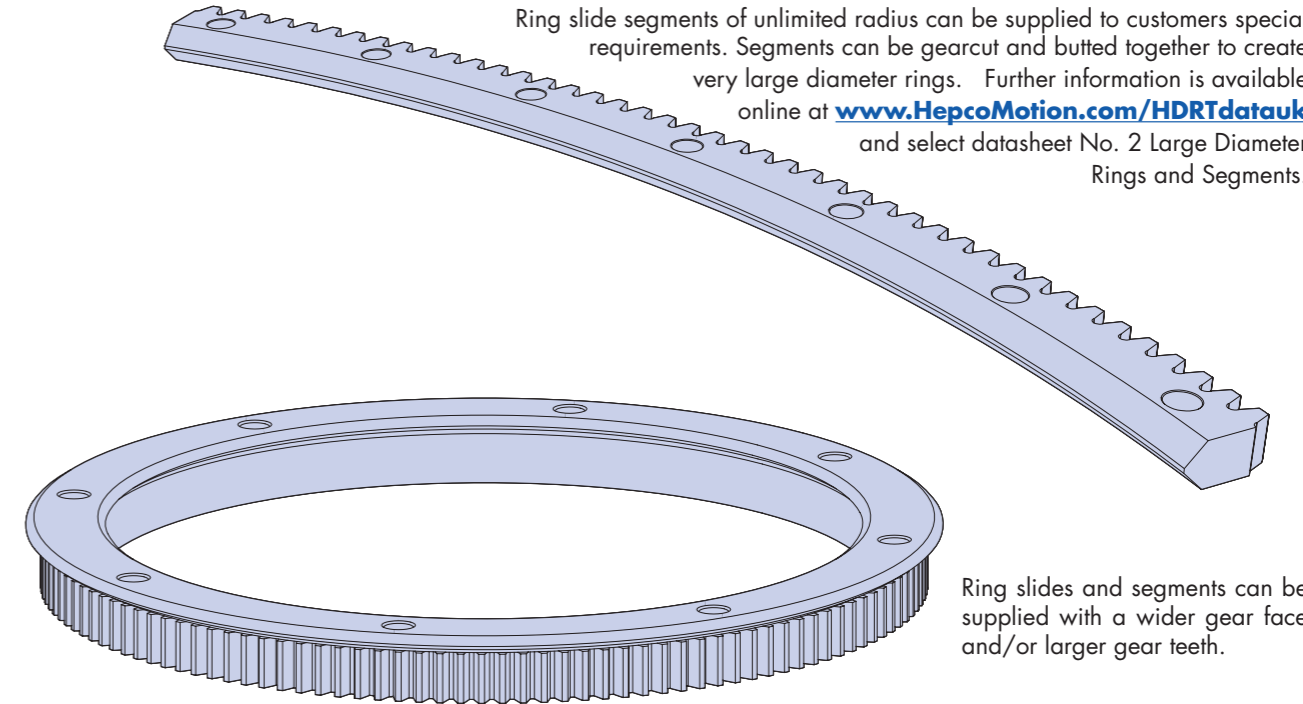
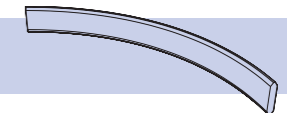

Ring slide segments of unlimited radius can be supplied to customers special requirements. Segments can be gearcut and butted together to create very large diameter rings. Further information is available online at [www.HepcoMotion.com/HDRTdatauk](http://www.HepcoMotion.com/HDRTdatauk) and select datasheet No. 2 Large Diameter Rings and Segments.

Ring slides and segments can be supplied with a wider gear face and/or larger gear teeth.

## Related Products



HDRT combines the flexibility and function of the PRT2 ring track system with the size and strength of the HepcoMotion HDS2 heavy duty slide system. HDRT has a large range of precision ground single edge V ring slides with high load capacity. There is also a track system combining double edge V ring segments and HD linear slides. For more details and catalogue visit [www.HepcoMotion.com/HDRTdatauk](http://www.HepcoMotion.com/HDRTdatauk)

- High load capacity up to 60kN
- 7 sizes of ring from 512 to 1656mm diameter with internal or external V
- Double edged V rings
- Track systems: limitless variety of open and closed circuits
- Stainless steel option
- Gearcut ring option with matching pinions
- Ø64, Ø95 & Ø120 bearings designed for ease of installation and setting
- Full range of fixed centre and bogie type carriages

Using the HepcoMotion PRT2 ring slides and track system as its basis, the DTS is a fully assembled unit ready to be incorporated into the customer's machine or framework. Carriages are driven around an oval or rectangular track with continuous or intermittent (indexing) motion. The belt driven carriages are rigidly guided along the precision track thus maintaining accurate alignment and resistance to deflection.

For more details and catalogue visit [www.HepcoMotion.com/DTSdatauk](http://www.HepcoMotion.com/DTSdatauk)

- Two sizes based on the PRT2 Track System size 25 and 44
- Oval or rectangular circuit format options
- Direct load capacity up to 4000N per carriage
- Carriage locking system for accurate repeatable positioning
- Mounts directly to HepcoMotion MCS Machine Construction System
- Ingenious safety trip latch mechanism disengages drive if carriage is impeded
- AC geared motor and gearbox options available

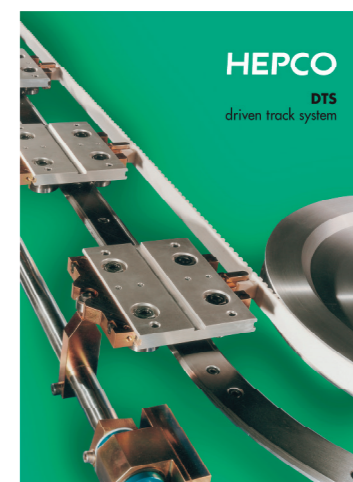



# HepcoMotion® Product Range



# Bishop-Wisecarver Product Range

HepcoMotion® – Exclusive European partners and distributors for Bishop-Wisecarver since 1984.

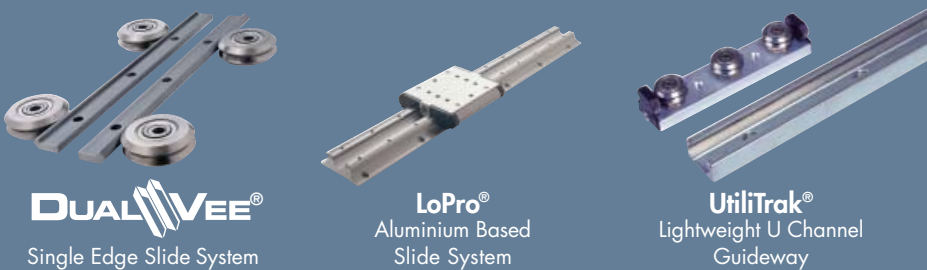

For further information on HepcoMotion® products – please request our leaflet 'FPL'

## HepcoMotion®

[www.HepcoMotion.com](http://www.HepcoMotion.com)

**HepcoMotion®**

Lower Moor Business Park, Tiverton Way, Tiverton, Devon, England EX16 6TG

Tel: +44 (0)1884 257000 Fax: +44 (0)1884 243500

E-mail: [sales@hepcotion.com](mailto:sales@hepcotion.com)

CATALOGUE No. PRT2 04 UK © 2013 Hepco Slide Systems Ltd.

Reproduction in whole or part without prior authorisation from Hepco is prohibited. Although every effort has been made to ensure the accuracy of the information in this catalogue, Hepco cannot accept liability for any omissions or errors. Hepco reserves the right to make alterations to the product resulting from technical developments.

Many Hepco products are protected by: Patents, Copyright, Design Right or Registered Design. Infringement is strictly prohibited and may be challenged in law. The Customer's attention is drawn to the following clause in Hepco's conditions of sale:

'It shall be the Customer's sole responsibility to ensure that goods supplied by Hepco will be suitable or fit for any particular application or purpose of the Customer, whether or not such application or purpose is known to Hepco. The Customer will be solely responsible for any errors in, or omissions from, any specifications or information the Customer provides. Hepco will not be obliged to verify whether any such specifications or information are correct or sufficient for any application or purpose.'

Hepco's full conditions of sale are available on request and will apply to all quotations and contracts for the supply of items detailed in this catalogue.

HepcoMotion is the trading name of Hepco Slide Systems Ltd.